



Contents



Warranty Information, Performance Assurance, and Application Limitation	Inside Cover
A Guide for using SUN Catalogs	iii
The SUN Code System for Ordering	viii
SUN Product Overview	xii
Technical Information about SUN Products	xiv
Cartridge Control Options	xvi
Section 11: LINE MOUNT BODIES	11.00.02
Line Mount Body Locator	11.00.02
Technical Tips	11.02
Line Mount Bodies	11.04
Series 1, T-13A	11.04
Series 1, T-10A	11.07
Series 1, T-11A	11.20
Series 1, T-21A	11.41
Series 1, T-31A	11.43
Series 2, T-5A	11.44
Series 2, T-3A	11.47
Series 2, T-2A	11.62
Series 2, T-22A	11.83
Series 2, T-32A	11.86
Series 3, T-16A	11.87
Series 3, T-17A	11.108
Series 3, T-23A	11.150
Series 3, T-33A	11.162
Series 4, T-18A	11.166
Series 4, T-19A	11.186
Series 4, T-24A	11.231
Series 4, T-34A	11.248
Section 12: SANDWICH BODIES	12.007
Sandwich Body Locator	12.007
Section 13: VALVE ASSEMBLY PACKAGES	13.00.02
Valve Assembly Locator	13.00.02
Valve Assembly Packages, Ordering Information	13.01
Electrical Connector Options for Solenoid Operated Assemblies	13.01
Valve Assemblies	13.02
Solenoid Operated Ventable Relief Assemblies	13.02
Solenoid and Relief Pilot Control Assembly	13.14
Cross-Port Relief Assemblies	13.15
Hydrostatic Transmission Assemblies	13.20
Hot Oil Shuttle and Relief Assemblies	13.28
Flow Divider/Combiner Tractive Drive Assemblies	13.38
Technical Tips on Regenerative Valves	13.42
Regeneration Assemblies	13.43
Accumulator Dump Assemblies	13.50
Pump Circuit Control Assemblies	13.52
Pressure-Compensated Priority Flow Control Assemblies	13.54
Valve Assembly Package Cross Reference Chart	13.57
Section 14: GENERAL INFORMATION	14.02
Direct Motor Mounting Bodies List	14.02
Cartridge Cavities and Cavity Tools	14.04
Solenoid Valve Interfaces	14.13
Cartridge Control Kits	14.14
Orifice Pressure Drop Data	14.15
Coil Information	14.16
Model Code Index	14.17
SUN Distributor Listing	Inside Back Cover



Prices for Sun Cavity Form Tools are net and not subject to discounts.

Prices for Custom Products and Modifications of Standard Valves are by quotation only.

Sun Hydraulics reserves the right to change existing prices and discounts at any time without notice to customers.

Selling prices are governed by the price list in effect at the time of acceptance of a purchase order.

Specifications, descriptions and illustrative material contained herein were as accurate as known at the time this publication was approved for printing.

SUN Hydraulics Corporation reserves the right to discontinue models at any time, or change prices, specifications or designs without notice or incurring obligation.

This catalog is published by SUN Hydraulics Corporation, 1500 West University Parkway, Sarasota, FL 34243 USA.

All rights reserved. This book, or any part thereof, may not be reproduced or transmitted in any form or by any means, electronic or mechanical, including photocopying, recording, or information storage and retrieval systems, for any purpose without the express written permission of SUN Hydraulics Corporation.

© 1994 SUN Hydraulics Corporation
Sarasota, FL 34243 USA

Printed in the United States of America

Catalog # 999-901-892

THREE SEPARATE SUN CATALOGS

SUN Hydraulics will be publishing a series of three separate catalogs to present the full range of SUN products to the marketplace.

1. **The Cartridge Catalog** presents SUN's two-piece, floating style screw-in cartridge valves.
2. **The Line Mount Body Catalog** contains line mount and direct motor mounted bodies and SUN pre-configured valve assemblies.
3. **The Sandwich Body Catalog** presents SUN's ISO 03, 05, 05 x, y, 07, 08, sandwiches and one to five station bar manifolds.

Important "Locators"

The three catalogs are cross referenced within a number of "Locators" that are placed at the beginning of catalog sections. Each Locator helps to identify and locate products not only in the catalog which you may be using, but also in the two other catalogs. Every catalog contains locators that reference products found in other SUN catalogs.

At the foundation of all locators are the SUN cavities, represented by the letter T-followed by a number and the letter A. (Example: T-3A) See page 14.04 for further information on SUN cavities. When the cavity configuration of a cartridge matches the cavity configuration in a mounting component, a physical fit is guaranteed. See the example below. However, it is important to note that because a physical fit between two components exists, it does not necessarily result in a logical and/or functional hydraulic circuit. Pay close attention to cartridge and cavity flow paths and pressure ratings to ensure a reasonable, functional circuit.

THE SUN LINE MOUNT BODY CATALOGUE

The SUN Hydraulics Line Mount Body Catalog contains 250 pages of line mount bodies and more than 50 pages of pre-configured valve assembly packages. Line mount bodies are categorized by frame size (Series 1, 2, 3, and 4), and within each frame size, by cavity (see Contents page i). Valve Assembly Packages are categorized by function (see Contents).

Line Mount Body Section

▶▶▶ Technical Tips

Line Mount Body Technical Tips provide information on the types of ports SUN offers, detailed specifications on materials (grade 6061 aluminum and grade 65-45-12 Ductile iron), and inch and metric specifications on SAE four-bolt flange patterns.

▶▶▶ Line Mount Body Locator (See Figure 2)

The Line Mount Body Locator appears on pages 11.00.01 through 11.00.31. and serves as a guide to identifying body styles and the location of body data pages

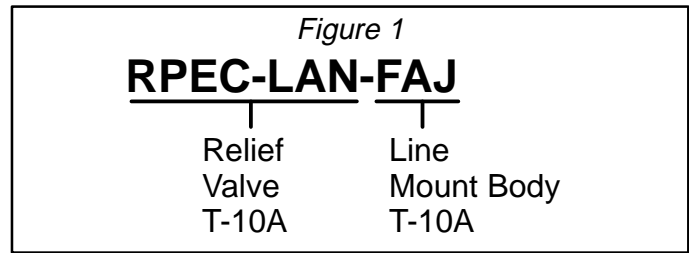

in the Line Mount Body Catalog. Complete physical descriptions including mounting configurations and material options of bodies can be found on body data pages.

Line mount bodies are categorized by cavity and include model codes, function symbols and page numbers of cartridges in the Cartridge Catalog that have identical cavity configurations. The sequence of appearance of the locators matches that of body data pages in the Line Mount Body Catalog. All frame size 1 cavities appear first; within each frame size grouping, two-port cavity bodies appear first, followed by three-port and four-port cavity bodies.

NOTE: Three-port bodies (T-2A, T-11A, T-17A, and T-19A cavities) with a high capacity port three are listed on separate locator pages from standard third port capacity bodies. This is done in an attempt to avoid confusion on what cartridges should be used in these bodies. Typically, only reducing/relieving and priority flow control cartridges are used in three-port bodies with a high capacity third port.

NOTE: It is critical to remember that a physical cavity match between cartridge and body does not necessarily guarantee a functional or logical hydraulic circuit. Before ordering any cartridge/body assembly, first look at both cartridge and body data pages to ensure the assembly results in a functional circuit.

▶▶▶ Line Mount Body Data Page (See Figure 3)

Data pages for line mount bodies provide all information required to specify and apply the product presented. The format of the page is presented in a consistent and easy to read style. Generally, there are two basic body styles shown on each page. (In some instances, one body with a multiplicity of port options occupies a single page.)

To help portray body configurations, a stylized rendering is included above and to the left of each body drawing. A schematic rendering is also presented for some of the more complicated bodies.

Below the stylized rendering is a list of cartridges, with their corresponding cartridge catalog page numbers, that can be used in the body shown. The cartridges listed on body data pages do not represent all possible combinations. However, the cartridges listed do guarantee a logical, functional circuit. Other cartridges with matching cavity configurations can also be used to create a logical, functional circuit.



Figure 2 Line Mount Body Locator

LINE MOUNT BODY LOCATOR
Cavity Size: T-10A

FUNCTIONS

Relief

Cartridge

	RPEC	RPEE	RDDA	RQEB	REAC			
Page	1.06	1.08	1.10	1.12	1.16			
Hydraulic Control Function								

MAIN PORT SIZE OPTIONS

SAE Flange				.75 061	.75 062	1.0 061	1.0 062	
NPTF Port	1/4 to .50	1/4 to .75	1/4 to 1.0					
SAE Port	1/4 to -10	1/4 to -12	1/4 to -16					
BSPP Port	1/4 to .50	1/4 to .75	1/4 to 1.0					

Configuration

Model No.	Model No.	Model No.	Model No.	Model No.	Model No.	Model No.	Model No.	Model
	FA*							
	11.07							
			FA 0	FA 3	FA P	FA 4		
			11.11	11.11	11.12	11.12		

Easy Reference Tab with Series and Cavity Size

TYPICAL CARTRIDGES USED WITH THIS BODY

CXDA - - -	Page 5.08
CXCD - - -	Page 5.10
NPCC - - -	Page 5.12
CNCC - - -	Page 5.14
NCCB - - -	Page 5.16
NCCC - - -	Page 5.18
FXCA - - -	Page 5.20
FCCB - - -	Page 5.22
FDBA - - -	Page 5.24
CSAA - - -	Page 10.08
CSAC - - -	Page 10.09
CDAA - - -	Page 10.11
CDAC - - -	Page 10.11
FDCA - - -	Page 10.14

Instructions for ordering complete cartridge and body assemblies. Page v

Pressure ratings, material specifications. Page H.02

ALUMINUM

Ports 1 & 2	Part Number
25 NPTF	GAA
27.5 NPTF	GAB
SAE-4	GAH
SAE-6	GAI
SAE-8	GAJ

DUCTILE IRON

Part Number
GAAS
GABS
GAHS
GAIS
GI

Figure 3 Line Mount Body Data Page

LINE MOUNT BODIES

- Aluminum rated to 3000 psi.
- Ductile Iron rated to 5000 psi.

90 degree body.

TYPICAL CARTRIDGES USED WITH THIS BODY

Charts showing Mounting Hole Configurations, Port Sizes and Model Codes for both Aluminum and Ductile Iron Bodies

Figure 5 Valve Assembly Package Data Page

HYDROSTATIC TRANSMISSION ASSEMBLY INLINE BODY

- Aluminum rated to 3000 psi and Ductile Iron rated to 5000 psi.
- Hot oil pressure can be confirmed and/or set with transmission in neutral.

These SUN valve assemblies are for use with hydrostatic transmissions to provide overload relief valve protection for the main circuit in both directions. Additionally, an auxiliary shuttle valve allows bleeding of hot oil from the low pressure side. Hot oil can be cooled, filtered, or used as a source of oil for flushing other pump and motor cases. Hot oil is removed from the loop when the SUN RPEC cartridge is set below the hydrostatic charge pressure relief valve.

NOTE: A mechanical brake is recommended to positively lock any stopped load.

Mounting Hole Dimensions	Parts 1 & 2		Part 7	Parts G1, G2, & G3		ALUMINUM		DUCTILE IRON	
	Inch	SAE-12	SAE-8	25 NPTF	L	Port Code	List Price*	Port Code	List Price*
Metric	.75 BSPP	.375 BSPP	25 BSPP	W				LIS	
								WIS	

*For part number and price for body only contact your local SUN distributor.

Function Symbol

Performance Data

Physical description of Valve Assembly

XRDB - LCN - A*

Valve Assembly Model Code

OPTIONS	Options	PORTS
CARTRIDGE RDDA Pg 1.10 For Viton Seals Change LCN to LCV. <td>Customer Specified Setting Stamped on Hex</td> <td>See Chart above</td>	Customer Specified Setting Stamped on Hex	See Chart above

General Information Section

All SUN catalogs contain a general information section for the customers reference. This section includes:

- A charted listing, by function, of motor mount bodies for Danfoss, Eaton, and Staffa motors.
- Cavity drawings for all SUN cavities in the catalog with model codes for cavity tooling.
- Model codes for various manufacturers solenoid valves charted by ISO interface.
- Orifice size pressure drop curves to be used when applying flow controls.
- A complete alphabetical index for all products in all three SUN catalogs.





LINE MOUNT BODY LOCATOR



LINE MOUNT BODY LOCATOR

Cavity Size: T-13A



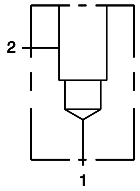









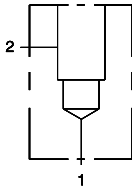
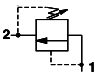



		FUNCTIONS									
		Check									
		Flow Control					Flow Fuse				
		Shuttle									
Cartridge	CXDA	CXCD	NFCC	CNCC	NCCB	NCCC	FXCA	FCCB	FDBA	CSAA	CSAC
Page	5.08	5.10	5.12	5.14	5.16	5.18	5.20	5.22	5.24	10.09	10.09
Hydraulic Control Function											
Cartridge	CDA A	CDAC	FQCA								
Page	10.11	10.11	10.14								
Hydraulic Control Function											
Main Port Type	MAIN PORT SIZE OPTIONS										
SAE Flange											
NPTF Port	up to .375	up to .50									
SAE Port	up to -8	up to -10									
BSPP Port	up to .375	up to .50									
Configuration	Model No.	Model No.	Model No.	Model No.	Model No.	Model No.	Model No.	Model No.	Model No.	Model No.	Model No.
	GA* 11.04										
	GC* 11.04										
	XW* 11.05										
	GN* 11.05										
	YS* 11.06										



LINE MOUNT BODY LOCATOR

Cavity Size: T-10A



FUNCTIONS	
	Relief
Cartridge	RPEC RPEE RDDA RQEB RBAC
Page	1.06 1.08 1.10 1.12 1.16
Hydraulic Control Function	    
Main Port Type	MAIN PORT SIZE OPTIONS
SAE Flange	.75 C61 .75 C62 1.0 C61 1.0 C62
NPTF Port	up to .50 up to .75 up to 1.0
SAE Port	up to -10 up to -12 up to -16
BSPP Port	up to .50 up to .75 up to 1.0
Configuration	Model No. Model No. Model No. Model No. Model No. Model No. Model No. Model No. Model No. Model No.
	FA* 11.07
	FAO FA3 FAP FA4 11.11 11.11 11.12 11.12
	FC* 11.08
	FE* 11.09
	WN* 11.10
	YF* 11.16
	YFO YF3 YFP YF4 11.17 11.17 11.18 11.18
	FN* 11.19
	FM* 11.19
NOTE: Line and sandwich bodies are available with SAE flange inlets and threaded port outlets. See pages 11.13 to 11.15.	



LINE MOUNT BODY LOCATOR

Cavity Size: T-11A







		FUNCTIONS									
		Vented Relief Sequence Reducing Pilot-to-Open Check Counterbalance					Logic Shuttle Back-to-Back Check Pilot-to-Close Check				
Cartridge	RBAD	RVCA	RSDC	SQDB	SCCA	PBDB	CBCA	CBCG	CBCH	CKCB	LODC
Page	1.17	1.18	2.06	2.08	2.12	3.06	4.10	4.12	4.14	4.16	9.08
Hydraulic Control Function											
Cartridge	LKDC	LPDC	LRDC	CSAB	CSAD	CDAB	CDAD	CODA			
Page	9.10	9.12	9.14	10.08	10.08	10.10	10.10	10.12			
Hydraulic Control Function											
Main Port Type	MAIN PORT SIZE OPTIONS										
SAE Flange			.75 C61	.75 C62							
NPTF Port	up to .375	up to .50									
SAE Port	up to -8	up to -10									
BSPP Port	up to .50	up to .50									
Configuration	Model No.	Model No.	Model No.	Model No.	Model No.	Model No.	Model No.	Model No.	Model No.	Model No.	Model No.
		EC*									
		11.20									
		EF*									
		11.22									
	EJ*										
	11.21										
		WR*									
		11.23									
		EH*									
		11.24									
	ZT*										
	11.24										
	ZR*, ZT* WPE										
	11.25										
			ZM*	WY*							
			11.27	11.27							
		ED*									
		11.28									
NOTE: Line and sandwich bodies are available with SAE flange inlets and threaded port outlets. See page 11.26.											

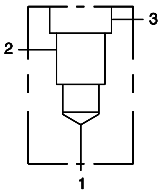
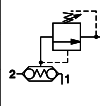
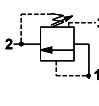
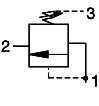
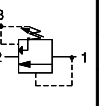
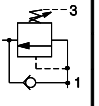
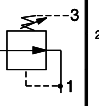
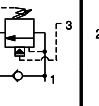
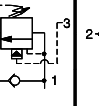
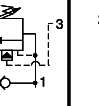
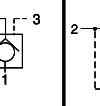

LINE MOUNT BODY LOCATOR

Cavity Size: T-11A (Continued)

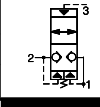
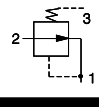
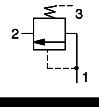
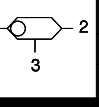
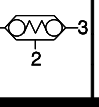
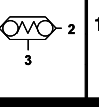
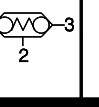
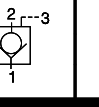
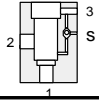
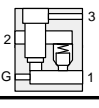
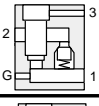
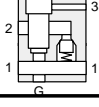
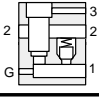
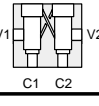
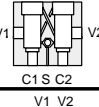
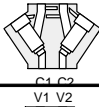

		FUNCTIONS										
		Vented Relief										Logic
												Shuttle
												Back-to-Back Check
												Pilot-to-Close Check
												Counterbalance
Cartridge	RBAD	RVCA	RSDC	SQDB	SCCA	PBDB	CBCA	CBCG	CBCH	CKCB	LODC	
Page	1.17	1.18	2.06	2.08	2.12	3.06	4.10	4.12	4.14	4.16	9.08	
Hydraulic Control Function												
Cartridge	LKDC	LPDC	LRDC	CSAB	CSAD	CDAB	CDAD	CODA				
Page	9.10	9.12	9.14	10.08	10.08	10.10	10.10	10.12				
Hydraulic Control Function												
Main Port Type	MAIN PORT SIZE OPTIONS											
SAE Flange			.75 C61	.75 C62								
NPTF Port	up to .375	up to .50										
SAE Port	up to -8	up to -10										
BSPP Port	up to .50	up to .50										
Configuration	Model No.	Model No.	Model No.	Model No.	Model No.	Model No.	Model No.	Model No.	Model No.	Model No.	Model No.	Model No.
		EG* 11.28										
		E2* 11.29										
		E6* 11.30										
		E7* 11.30										
		E3* 11.31										
		YE* 11.32										
		YG* 11.32										
	XV* 11.33	XE* 11.34										
	XG* 11.34											
												NOTE: Line and sandwich bodies are available with SAE flange inlets and threaded port outlets. See page 11.27.



LINE MOUNT BODY LOCATOR

Cavity Size: T-11A (Continued)

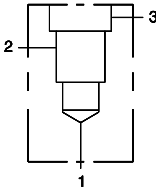

		FUNCTIONS									
		Vented Relief	Logic	Sequence	Shuttle	Reducing	Back-to-Back Check	Pilot-to-Open Check	Pilot-to-Close Check	Counterbalance	
Cartridge	RBAD	RVCA	RSDC	SQDB	SCCA	PBDB	BCBA	CBCG	CBCH	CKCB	LODC
Page	1.17	1.18	2.06	2.08	2.12	3.06	4.10	4.12	4.14	4.16	9.08
Hydraulic Control Function											
Cartridge	LKDC	LPDC	LRDC	CSAB	CSAD	CDAB	CDAD	CODA			
Page	9.10	9.12	9.14	10.08	10.08	10.10	10.10	10.12			
Hydraulic Control Function											
Main Port Type	MAIN PORT SIZE OPTIONS										
SAE Flange											
NPTF Port	up to .25	up to .375	up to .50	up to .75							
SAE Port	up to -6	up to -6	up to -10	up to -12							
BSP Port	up to .25	up to .375	up to .50	up to .75							
Configuration	Model No.	Model No.	Model No.	Model No.	Model No.	Model No.	Model No.	Model No.	Model No.	Model No.	Model No.
		YV* 11.35									
				XO* 11.35							
				EM* 11.36							
				EN* 11.36							
				EP* 11.37							
				EQ* 11.37							
				E8* 11.38							
				E9* 11.38							
	XV* 11.39										
NOTE: Line and sandwich bodies are available with SAE flange inlets and threaded port outlets. See page 11.27.											



LINE MOUNT BODY LOCATOR

Cavity Size: T-21A











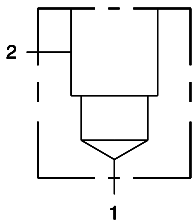

		FUNCTIONS									
		Vented Relief					Ventable Priority Flow Control				
		Reducing/Relieving with Drain					Directional Control				
		Reducing/Relieving with Vent									
		Vented Counterbalance									
		Vented Pilot-to-Open Check									
Cartridge	RVCD	PVDA	PVDB	CWCA	CWCG	CVCV	FVCA	DPBM	DPBN	DPBO	DPBP
Page	1.20	3.14	3.16	4.18	4.20	4.22	6.04	8.10	8.11	8.12	8.13
Hydraulic Control Function											
Main Port Type	MAIN PORT SIZE OPTIONS										
SAE Flange											
NPTF Port	up to .50										
SAE Port	up to -10										
BSPP Port	up to .50										
Configuration	Model No.	Model No.	Model No.	Model No.	Model No.	Model No.	Model No.	Model No.	Model No.	Model No.	Model No.
	MA* 11.41										
	M4* 11.41										
	XP* 11.42										
	XF* 11.42										



LINE MOUNT BODY LOCATOR

Cavity Size: T-5A

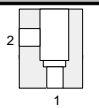
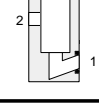
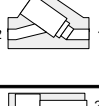
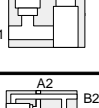
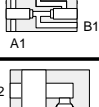
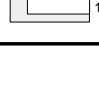

		FUNCTIONS									
		Check									
		Flow Control					Flow Fuse				
Cartridge	CXFA	CXED	NFDC	CNEC	NCEB	NCEC	FXDA	FCDB	FDCB	FQEA	
Page	5.08	5.10	5.12	5.14	5.16	5.18	5.20	5.22	5.24	10.14	
Hydraulic Control Function											
Main Port Type	MAIN PORT SIZE OPTIONS										
SAE Flange			.75 C61								
NPTF Port	up to .50	up to .75									
SAE Port	up to -10	up to -12									
BSPP Port	up to .50	up to .75									
Configuration	Model No.	Model No.	Model No.	Model No.	Model No.	Model No.	Model No.	Model No.	Model No.	Model No.	Model No.
	DA* 11.44										
			ZKS 11.44								
	DC* 11.45										
		XW* 11.45									
		YS* 11.46									
		DN* 11.46									



LINE MOUNT BODY LOCATOR

Cavity Size: T-3A

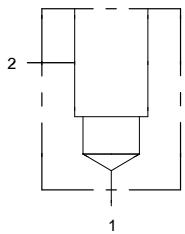

		FUNCTIONS									
		Relief					Air Bleed and Start-Up				
Cartridge	RPGC	RPGE	RDFA	RQGB	RPGD	RBAA	RBAB	NQEB			
Page	1.06	1.08	1.10	1.12	1.14	1.16	1.14	10.16			
Hydraulic Control Function											
Main Port Type	MAIN PORT SIZE OPTIONS										
SAE Flange				.75 C61	.75 C61	1.0 C61	1.0 C62	1.25 C61	1.25 C62		
NPTF Port	up to .75	up to .75	up to 1.0								
SAE Port	up to -10	up to -12	up to -16								
BSPP Port	up to .75	up to .75	up to 1.0								
Configuration	Model No.	Model No.	Model No.	Model No.	Model No.	Model No.	Model No.	Model No.	Model No.	Model No.	Model No.
		CA* 11.47									
			CA* 11.47	CAO 11.50	CA3 11.50	CAP 11.51	CA4 11.51	CAQ 11.52	CA5 11.52		
	CG* 11.48										
		CE* 11.48	CE* 11.49								
	YB* 11.58										
			YC* 11.58			YCP 11.59	YC4 11.59	YCQ 11.60	YC5 11.60		
	CN* 11.61										
		CM* 11.61									
						NOTE: Line and sandwich bodies are available with SAE flange inlets and threaded port outlets. See pages 11.53 to 11.57					



LINE MOUNT BODY LOCATOR

Cavity Size: T-2A



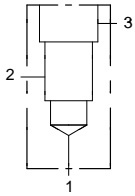



		FUNCTIONS									
		Vented Relief Sequence Reducing Counterbalance Pilot-to-Open Check					Logic Pilot-to-Close Check				
Cartridge	RVEA	RSFC	SQFB	RSFE	SCEA	PBFB	PBFC	CBEA	CBEG	CBEH	CKEB
Page	1.18	2.06	2.08	2.10	2.12	3.06	3.08	4.10	4.12	4.14	4.16
Hydraulic Control Function											
Cartridge	LOFC	LKFC	LPFC	LRFC	COFA						
Page	9.08	9.10	9.12	9.14	10.12						
Hydraulic Control Function											
Main Port Type	MAIN PORT SIZE OPTIO.04.03NS										
SAE Flange				.75 to C61	.75 to C62						
NPTF Port	up to .50	up to .75	up to .75								
SAE Port	up to -8	up to -10	up to -12								
BSPP Port	up to .50	up to .75	up to .75								
Configuration	Model No.	Model No.	Model No.	Model No.	Model No.	Model No.	Model No.	Model No.	Model No.	Model No.	Model No.
			BC* 11.62								
			BF* 11.64								
			BV* 11.65								
				ZNV 11.69	ZDS 11.69						
			WS* 11.66								
			BH* 11.65								
	ZT* 11.71										
	ZTX, ZRM 11.71										
		BD* 11.63									
						NOTE: Line and sandwich bodies are available with SAE flange inlets and threaded port outlets. See pages 11.67 to 11.70.					

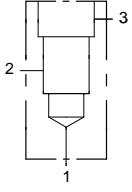
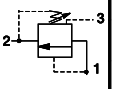
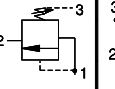
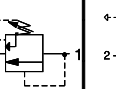
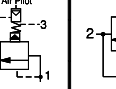
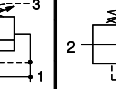
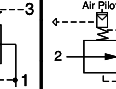
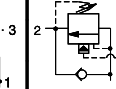
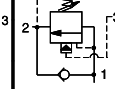
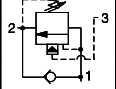
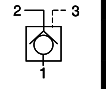

LINE MOUNT BODY LOCATOR

Cavity Size: T-2A (Continued)

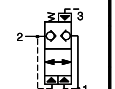
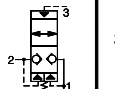
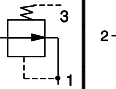
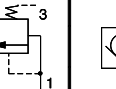
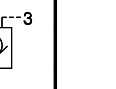
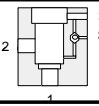
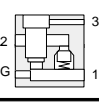
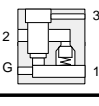
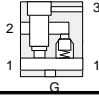
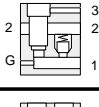
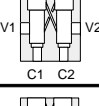
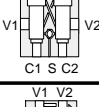
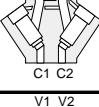











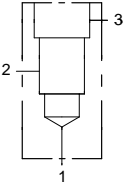
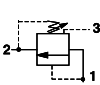





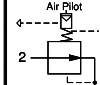



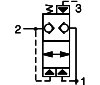



		FUNCTIONS										
		Vented Relief										Logic
												Pilot-to-Close Check
Cartridge	RVEA	RSFC	SQFB	RSFE	SCEA	PBFB	PBFC	CBEA	CBEG	CBEH	CKEB	
Page	1.18	2.06	2.08	2.10	2.12	3.06	3.08	4.10	4.12	4.14	4.16	
Hydraulic Control Function												
Cartridge	LOFC	LKFC	LPFC	LRFC	COFA							
Page	9.08	9.10	9.12	9.14	10.12							
Hydraulic Control Function												
Main Port Type	MAIN PORT SIZE OPTIONS											
SAE Flange												
NPTF Port	up to .75	up to .75										
SAE Port	up to -10	up to -12										
BSPP Port	up to .75	up to .75										
Configuration	Model No.	Model No.	Model No.	Model No.	Model No.	Model No.	Model No.	Model No.	Model No.	Model No.	Model No.	Model No.
	BG* 11.70											
	B2* 11.72											
	B6* 11.74											
	B7* 11.74											
	B3* 11.73											
	YA* 11.78											
	YH* 11.78											
	WP*, VY* 11.75 XA* 11.76											
	XH* 11.76											
												NOTE: Line and sandwich bodies are available with SAE flange inlets and threaded port outlets. See pages 11.67 to 11.70.



LINE MOUNT BODY LOCATOR

Cavity Size: T-2A (Continued)



		FUNCTIONS									
		Vented Relief									Logic
		Sequence								Pilot-to-Close Check	
		Reducing									
		Counterbalance									
		Pilot-to-Open Check									
Cartridge	RVEA	RSFC	SQFB	RSFE	SCEA	PBFB	PBFC	CBEA	CBEG	CBEH	CKEB
Page	1.18	2.06	2.08	2.10	2.12	3.06	3.08	4.10	4.12	4.14	4.16
Hydraulic Control Function											
Cartridge	LOFC	LKFC	LPFC	LRFC	COFA						
Page	9.08	9.10	9.12	9.14	10.12						
Hydraulic Control Function											
Main Port Type	MAIN PORT SIZE OPTIONS										
SAE Flange											
NPTF Port	uo to .50	up to .75	up to .75	up to 1.0							
SAE Port	up to -8	up to -10	up to -12	up to -16							
BSPP Port	up to .50	up to .75	up to .75	up to 1.0							
Configuration	Model No.	Model No.	Model No.	Model No.	Model No.	Model No.	Model No.	Model No.	Model No.	Model No.	Model No.
	YV*										
	11.77										
				XB*							
				11.81							
				BM*							
				11.79							
				BN*							
				11.79							
				BP*							
				11.80							
				BQ*							
				11.80							
		B8*									
		11.81									
				YP*							
				11.82							
				YP*							
				11.82							
											NOTE: Line and sandwich bodies are available with SAE flange inlets and threaded port outlets. See pages 11.67 to 11.70.



LINE MOUNT BODY LOCATOR

Cavity Size: T-22A

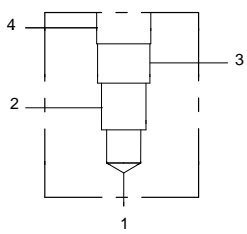
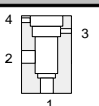
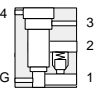
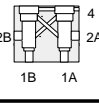
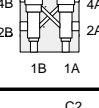
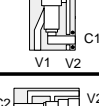
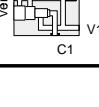

FUNCTIONS	
	<div style="display: flex; justify-content: space-between;"> <div style="width: 45%;"> <p>Vented Relief</p> <p>Reducing/Relieving with Drain</p> <p>Reducing/Relieving with Vent</p> <p>Vented Pilot-to-Open Check</p> </div> <div style="width: 45%;"> <p>Vented Counterbalance</p> <p>Ventable Priority Flow Control</p> <p>Directional Control</p> </div> </div>
Cartridge	FUNCTIONS
Page	FUNCTIONS
Hydraulic Control Function	FUNCTIONS
Main Port Type	MAIN PORT SIZE OPTIONS
SAE Flange	
NPTF Port	up to .50
SAE Port	up to -8
BSPP Port	up to .50
Configuration	Model No.
	NA* 11.83
	N4* 11.83
	XI* 11.84
	XR* 11.84
	WJ* 11.85
	VZ* 11.85



LINE MOUNT BODY LOCATOR

Cavity Size: T-16A



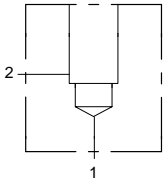









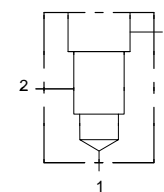







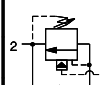

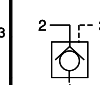



FUNCTIONS												
		Check					Flow Fuse					
		Flow Control					Relief					
Cartridge	RPIC	RPIE	RDHA	RQIB	RPID	CXHA	CXGD	NFEC	CNGC	NCFB	NCFC	
Page	1.07	1.09	1.11	1.13	1.15	5.09	5.11	5.13	5.15	5.17	5.19	
Hydraulic Control Function												
Cartridge	FXEA	FCEB	FDEA	FQGA								
Page	5.21	5.23	5.25	10.15								
Hydraulic Control Function												
Main Port Type	MAIN PORT SIZE OPTIONS											
SAE Flange		1.0 C61	1.0 C62	1.25 C61	1.25 C62	1.5 C61	1.5 C62	2.0 C61	2.0 C62			
NPTF Port	up to 1.25											
SAE Port	up to -20											
BSPP Port	up to 1.25											
Configuration	Model No.	Model No.	Model No.	Model No.	Model No.	Model No.	Model No.	Model No.	Model No.	Model No.	Model No.	
	IA*	IAP	IA4	IAQ	IA5	IAR	IA6	IAS	IA8			
	11.87	11.89	11.89	11.90	11.90	11.91	11.91	11.93	11.93			
	IC*	ICP										
	11.87	11.88										
	IE*	IEP	IE4	IEQ	IE5	IER	IE6	IES	IE8			
	11.88	11.94	11.94	11.95	11.95	11.96	11.96	11.97	11.97			
	YI*					YIR	YI6	YIS	YI8			
	11.101					11.102	11.102	11.103	11.103			
	IN*	INP	IN4	INQ	IN5							
	11.104	11.105	11.105	11.106	11.106							
	YS*											
	11.104											
	IM*											
	11.107											
	WN*											
	11.107											
NOTE: Line and sandwich bodies are available with SAE flange inlets and threaded port outlets. See pages 11.98 to 11.100.												

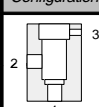
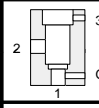

LINE MOUNT BODY LOCATOR

Cavity Size: T-17A





		FUNCTIONS									
		Vented Relief									Logic
		Sequence									Pilot-to-Close Check
		Reducing									
		Counterbalance									
		Pilot-to-Open Check									
Cartridge	RVGA	RSHC	SQHB	RSHE	SCGA	PBHB	PBHC	CBGA	CBGG	CBGH	CKGB
Page	1.19	2.07	2.09	2.11	2.13	3.07	3.09	4.11	4.13	4.15	4.17
Hydraulic Control Function											
Cartridge	LOHC	LKHC	LPHC	LRHC	COHA						
Page	9.09	9.11	9.13	9.15	10.13						
Hydraulic Control Function											
Main Port Type	MAIN PORT SIZE OPTIONS										
SAE Flange				.75 C61	.75 C62	1.0 C61	1.0 C62	1.25C61	1.25C62		
NPTF Port	up to .75	up to 1.0	up to 1.25								
SAE Port	up to -12	up to -16	up to -20								
BSPP Port	up to .75	up to 1.0	up to 1.25								
Configuration	Model No.	Model No.	Model No.	Model No.	Model No.	Model No.	Model No.	Model No.	Model No.	Model No.	Model No.
			HC* 11.108			HCP 11.114	HC4 11.114	HCQ 11.115	HC5 11.115		
			HF* 11.108			HFP 11.116	HF4 11.116	HFQ 11.117	HF5 11.117		
		HD* 11.109									
				WGL 11.128	WNG 11.128	ZNW 11.129	ZDR 11.129	ZJY 11.130			
		WS*, WT* 11.111									
		HH* 11.110				HHP 11.120	HH4 11.120	HHQ 11.121	HH5 11.121		
	ZT* 11.112										
			HG* 11.123			HGP 11.123		HGQ 11.124	HG5 11.124		
	ZRN, ZTW 11.122					NOTE: Line and sandwich bodies are available with SAE flange inlets and threaded port outlets. See page 11.125 to 11.130.					



LINE MOUNT BODY LOCATOR

Cavity Size: T-17A (Continued)

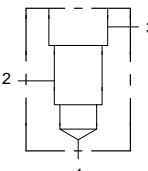
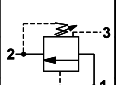
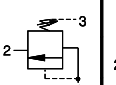
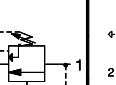
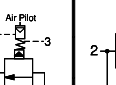
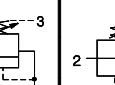
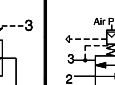
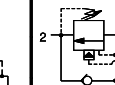
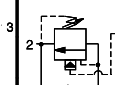
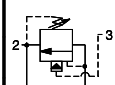
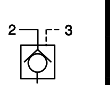
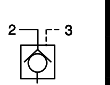
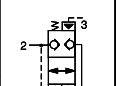
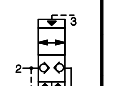
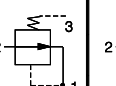
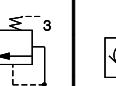
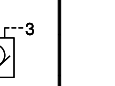
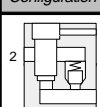
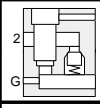
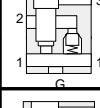
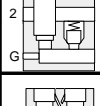
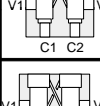
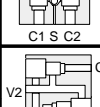
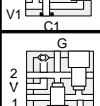
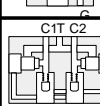

		FUNCTIONS									
		Vented Relief Sequence Reducing Counterbalance Pilot-to-Open Check					Logic Pilot-to-Close Check				
Cartridge	RVGA	RSHC	SQHB	RSHE	SCGA	PBHB	PBHC	CBGA	CBGG	CBGH	CKGB
Page	1.19	2.07	2.09	2.11	2.13	3.07	3.09	4.11	4.13	4.15	4.17
Hydraulic Control Function											
Cartridge	LOHC	LKHC	LPHC	LRHC	COHA						
Page	9.09	9.11	9.13	9.15	10.13						
Hydraulic Control Function											
Main Port Type	MAIN PORT SIZE OPTIONS										
SAE Flange			1.0 C61	1.0 C62	1.25 C61	1.25 C62					
NPTF Port	up to .75	up to 1.25									
SAE Port	up to -16	up to -20									
BSPP Port	up to .75	up to 1.25									
Configuration	Model No.	Model No.	Model No.	Model No.	Model No.	Model No.	Model No.	Model No.	Model No.	Model No.	Model No.
			H2P 11.140	H24 11.140	H2Q 11.142	H25 11.142					
		H6* 11.138		H64 11.137		H65 11.137					
		H7* 11.138									
		H3* 11.139	H3P 11.141								
		YJ* 11.131	YJP 11.132		YJQ 11.132						
		YK* 11.131	YKP 11.133		YKQ 11.133						
	YV* 11.113										
		XC* 11.147	XCP 11.148	XC4 11.148	XCQ 11.149	XC5 11.149					
		HM* 11.134									
						NOTE: Line and sandwich bodies are available with SAE flange inlets and threaded port outlets. See page 11.125 to 11.130.					



LINE MOUNT BODY LOCATOR

Cavity Size: T-23A



	FUNCTIONS									
	Vented Relief	Vented Counterbalance								
Reducing/Relieving with Drain	Vented Pilot-to-Open Check									
Reducing/Relieving with Vent	Ventable Priority Flow Control									

Cartridge	RVGD	PVHA	PVHB	CWGA	CWGG	CVGV	FVEA				
Page	1.21	3.15	3.17	4.19	4.21	4.23	6.05				
Hydraulic Control Function											

Main Port Type	MAIN PORT SIZE OPTIONS										
----------------	------------------------	--	--	--	--	--	--	--	--	--	--

SAE Flange		1.0 C61	1.0 C62	1.25 C61	1.25 C62						
NPTF Port	up to 1.25										
SAE Port	up to -20										
BSPP Port	up to 1.25										

Configuration	Model No.	Model No.	Model No.	Model No.	Model No.	Model No.	Model No.	Model No.	Model No.	Model No.	Model No.
	PA* 11.150	PAP 11.151	PA4 11.151	PAQ 11.153	PA5 11.153						
	P4* 11.159	P4P 11.160	P44 11.160	P4Q 11.161	P45 11.161						
	XM* 11.154	XMP 11.155	XM4 11.155	XMQ 11.156	XM5 11.156						
	VA* 11.154	VAP 11.157	VA4 11.157	VAQ 11.158	VA5 11.158						
			WHA 11.152								











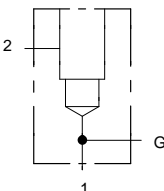





11



LINE MOUNT BODY LOCATOR

Cavity Size: T-18A



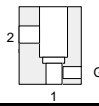
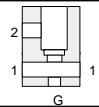
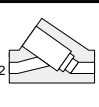
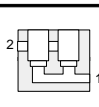
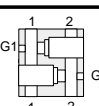
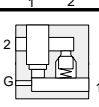







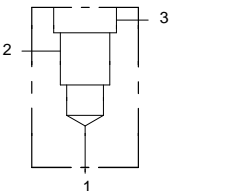
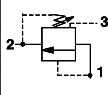
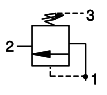
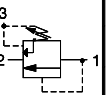
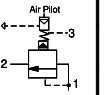
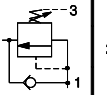
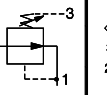
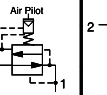
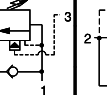
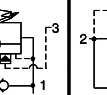
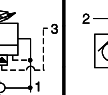

		FUNCTIONS									
		Relief	Flow Fuse								
		Check									
		Flow Control									
Cartridge	RPKC	RPKE	RDJA	RQKB	RPKD	CXJA	CXID	NFFC	CNIC	NCGB	NCGC
Page	1.07	1.09	1.11	1.13	1.15	5.09	5.11	5.13	5.15	5.17	5.19
Hydraulic Control Function											
Cartridge	FXFA	FCFB	FDFA	FQIA							
Page	5.21	5.23	5.25	10.15							
Hydraulic Control Function											
Main Port Type	MAIN PORT SIZE OPTIONS										
SAE Flange		1.0 C61	1.0 C62	1.25 C61	1.25 C62	1.50 C61	1.50 C62	2.0 C61	2.0 C62		
NPTF Port	up to 1.25										
SAE Port	up to -20										
BSPP Port	up to 1.25										
Configuration	Model No.	Model No.	Model No.	Model No.	Model No.	Model No.	Model No.	Model No.	Model No.	Model No.	Model No.
	LA* 11.166	LAP 11.167	LA4 11.167	LAQ 11.168	LA5 11.168	LAR 11.169	LA6 11.169	LAS 11.170	LA8 11.170		
	LE* 11.166	LEP 11.172	LE4 11.172	LEQ 11.173	LE5 11.173	LER 11.174	LE6 11.174	LES 11.175	LE8 11.175		
						ZLS 11.171		ZLR 11.171			
								XZY 11.179			
						YLR 11.180	YL6 11.180	YLS 11.181	YL8 11.181		
	LN* 11.182			LNQ 11.183	LN5 11.183	LNR 11.184	LN6 11.184	LNS 11.185	LN8 11.185		
NOTE: Line and sandwich bodies are available with SAE flange inlets and threaded port outlets. See pages 11.176 to 11.178.											

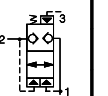
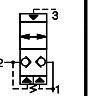
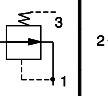
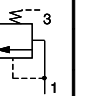
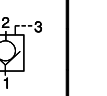

LINE MOUNT BODY LOCATOR

Cavity Size: T-19A



		FUNCTIONS										
		Vented Relief										Logic
												Pilot-to-Open Check
												Pilot-to-Close Check
Cartridge	RVIA	RSJC	SQJB	RSJE	SCIA	PBJB	PBJC	CBIA	CBIG	CBIH	CKIB	
Page	1.19	2.07	2.09	2.11	2.13	3.07	3.09	4.11	4.13	4.15	4.17	
Hydraulic Control Function												
Cartridge	LOJC	LKJC	LPJC	LRJC	COJA							
Page	9.09	9.11	9.13	9.15	10.13							
Hydraulic Control Function												
Main Port Type	MAIN PORT SIZE OPTIONS											
SAE Flange		1.0 C61	1.0 C62	1.25 C61	1.25 C62	1.50 C61	1.50 C62	2.0 C61	2.0 C62			
NPTF Port	up to 1.25											
SAE Port	up to -20											
BSPP Port	up to 1.25											
Configuration	Model No.	Model No.	Model No.	Model No.	Model No.	Model No.	Model No.	Model No.	Model No.	Model No.	Model No.	Model No.
	KC*	KCP	KC4	KCQ	KC5	KCR	KC6	KCS	KC8			
	11.186	11.190	11.190	11.192	11.192	11.195	11.195	11.198	11.198			
	KF*	KFP	KF4	KFQ	KF5	KFR	KF6	KFS	KF8			
	11.186	11.191	11.191	11.193	11.193	11.196	11.196	11.199	11.199			
	KH*	KHP	KH4	KHQ	KH5	KHR	KH6	KHS	KH8			
	11.187	11.201	11.201	11.202	11.202	11.203	11.203	11.204	11.204			
	WT*											
	11.188											
						ZLQ		ZLP				
						11.189		11.189				
				ZNX	ZFY	ZNY	ZDQ					
				11.205	11.205	11.206	11.206					
								XZZ,XVD				
								11.211				
						YRD		YRC				
						11.212		11.213				
						NOTE: Line and sandwich bodies are available with SAE flange inlets and threaded port outlets. See pages 11.207 to 11.210.						



LINE MOUNT BODY LOCATOR

Cavity Size: T-24A



		FUNCTIONS									
		Vented Relief					Vented Counterbalance				
		Reducing/Relieving with Drain					Vented Pilot-to-Open Check				
		Reducing/Relieving with Vent					Ventable Priority Flow Control				
Cartridge	RVID	PVJA	PVJB	CWIA	CWIG	CVIV	FVFA				
Page	1.21	3.15	3.17	4.19	4.21	4.23	6.05				
Hydraulic Control Function											
Main Port Type	MAIN PORT SIZE OPTIONS										
SAE Flange		1.0 C61	1.0 C62	1.25 C61	1.25 C62	1.50 C61	1.50 C62	2.0 C61	2.0 C62		
NPTF Port	up to 1.25										
SAE Port	up to -20										
BSPP Port	up to 1.25										
Configuration	Model No.	Model No.	Model No.	Model No.	Model No.	Model No.	Model No.	Model No.	Model No.	Model No.	Model No.
	QC* 11.231			QCQ 11.232	QC5 11.232	QCR 11.233	QC6 11.233	QCS 11.234	QC8 11.234		
	QA* 11.231			QAQ 11.235	QA5 11.235	QAR 11.236	QA6 11.236	QAS 11.237	QA8 11.237		
			WGY 11.238		WGZ 11.238		WGT 11.239				
	XL* 11.240					XLR 11.241	XL6 11.241	XLS 11.242	XL8 11.242		
	XS* 11.240					XSR 11.243	XS6 11.243	XSS 11.244	XS8 11.244		
	Q4* 11.245					Q4R 11.246	Q46 11.246	Q4S 11.247	Q48 11.247		



NOTES







Sun offers many single and multiple cavity standard line mount manifolds, and many sandwich, motor mount bodies and subplates that are available in a choice of aluminum (3000 psi/210 bar) or ductile iron (5000 psi/350 bar). Ports include NPTF, SAE, BSPP and Code 61 and Code 62 flanges.

Go to www.sunhydraulics.com. *Example:* Click Product: Manifolds: Line Mount: Flow Controls: Inline: and a pop-up menu shows all the available **SAE Ported Bodies** within your selection (see below). When you click the body in the appropriate Cavity column, the **body page will show all measurements, Technical Data and full orientation views of all body faces**. See [Technical Information](#) section of web site for additional information.

Please hover over the manifolds in order to view porting information.

Port Size	T-162A	T-13A	T-5A	T-16A	T-18A
1/4" NPTF		GCA			
1/4" NPTF	ACA	GCA/S			
1/4" NPTF	ACA/S				
3/8" NPTF		GCB			
3/8" NPTF	ACB	GCB/S			
3/8" NPTF	ACB/S		DCB		
3/8" NPTF			DCB/S		
1/2" NPTF		GCC			
1/2" NPTF		GCC/S	DCC		
1/2" NPTF			DCC/S		
3/4" NPTF				ICD	
3/4" NPTF			VFJ	ICD/S	
3/4" NPTF			VFJ/S		
1" NPTF				ICE	
1" NPTF			VFK	ICE/S	
1" NPTF			VFK/S		
1 1/4" NPTF				ICF	
1 1/4" NPTF			VFL	ICF/S	
1 1/4" NPTF			VFL/S		
SAE 4		GCH			
SAE 4	ACH	GCH/S			
SAE 4	ACH/S				
SAE 6		GCI			
SAE 6	ACI	GCI/S			
SAE 6	ACI/S		DCI		
SAE 6			DCI/S		
SAE 8		GCJ			
SAE 8		GCJ/A			
SAE 8		GCJ/S	DCJ		
SAE 8			DCJ/S		
SAE 10			DCK		
SAE 10			DCK/S		
SAE 12				ICL	



Sun offers many single and multiple cavity standard line mount manifolds, and many sandwich, motor mount bodies and subplates that are available in a choice of aluminum (3000 psi/210 bar) or ductile iron (5000 psi/350 bar). Ports include NPTF, SAE, BSPP and Code 61 and Code 62 flanges.

Go to www.sunhydraulics.com. *Example:* Click Product: Manifolds: Line Mount: Flow Controls: Inline: and a pop-up menu shows all the available **SAE Ported Bodies** within your selection (see below). When you click the body in the appropriate Cavity column, the **body page will show all measurements, Technical Data and full orientation views of all body faces**. See [Technical Information](#) section of web site for additional information.

Please hover over the manifolds in order to view porting information.

Port Size	T-162A	T-13A	T-5A	T-16A	T-18A
1/4" NPTF		GCA			
1/4" NPTF	ACA	GCA/S			
1/4" NPTF	ACA/S				
3/8" NPTF		GCB			
3/8" NPTF	ACB	GCB/S			
3/8" NPTF	ACB/S		DCB		
3/8" NPTF			DCB/S		
1/2" NPTF		GCC			
1/2" NPTF		GCC/S	DCC		
1/2" NPTF			DCC/S		
3/4" NPTF				ICD	
3/4" NPTF			VFJ	ICD/S	
3/4" NPTF			VFJ/S		
1" NPTF				ICE	
1" NPTF			VFK	ICE/S	
1" NPTF			VFK/S		
1 1/4" NPTF				ICF	
1 1/4" NPTF			VFL	ICF/S	
1 1/4" NPTF			VFL/S		
SAE 4		GCH			
SAE 4	ACH	GCH/S			
SAE 4	ACH/S				
SAE 6		GCI			
SAE 6	ACI	GCI/S			
SAE 6	ACI/S		DCI		
SAE 6			DCI/S		
SAE 8		GCJ			
SAE 8		GCJ/A			
SAE 8		GCJ/S	DCJ		
SAE 8			DCJ/S		
SAE 10			DCK		
SAE 10			DCK/S		
SAE 12				ICL	



LINE MOUNT BODIES



- Aluminum rated to 3000 psi.
- Ductile Iron rated to 5000 psi.

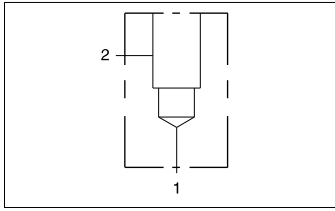

90 degree body.

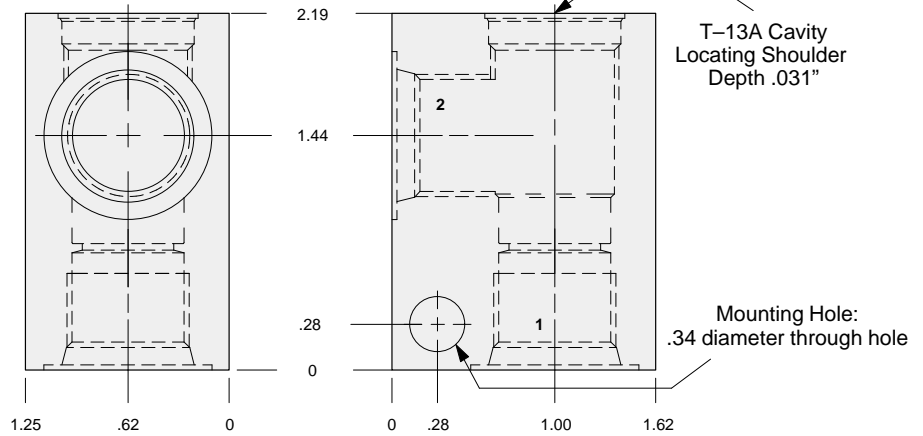

TYPICAL CARTRIDGES USED WITH THIS BODY

CXDA - ***	Page 5.08
CXCD - ***	Page 5.10
NFCC - ***	Page 5.12
CNCC - ***	Page 5.14
NCCB - ***	Page 5.16
NCCC - ***	Page 5.18
FXCA - ***	Page 5.20
FCCB - ***	Page 5.22
FDBA - ***	Page 5.24
CSAA - ***	Page 10.09
CSAC - ***	Page 10.09
CDA - ***	Page 10.11
CDAC - ***	Page 10.11
FQCA - ***	Page 10.14

Instructions for ordering complete cartridge and body assemblies. Page v

Pressure ratings, material specifications. Page 11.02

Ports 1 & 2	ALUMINUM		DUCTILE IRON	
	Part Number		Part Number	
.25 NPTF	GAA		GAA/S	
.375 NPTF	GAB		GAB/S	
SAE-4	GAH		GAH/S	
SAE-6	GAI		GAI/S	
SAE-8	GAJ		GAJ/S	
.25 BSPP	GAT		GAT/S	
.375 BSPP	GAU		GAU/S	

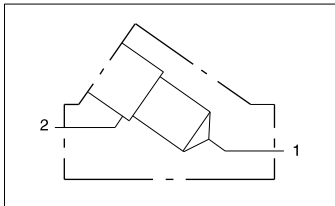

Inline body.

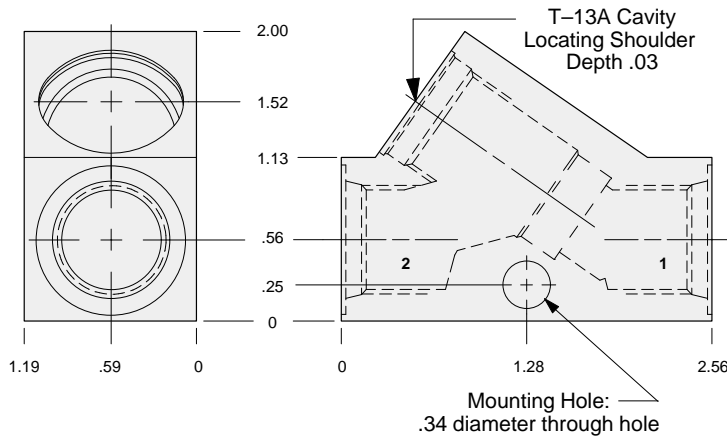

TYPICAL CARTRIDGES USED WITH THIS BODY

CXDA - ***	Page 5.08
CXCD - ***	Page 5.10
NFCC - ***	Page 5.12
CNCC - ***	Page 5.14
NCCB - ***	Page 5.16
NCCC - ***	Page 5.18
FXCA - ***	Page 5.20
FCCB - ***	Page 5.22
FDBA - ***	Page 5.24
CSAA - ***	Page 10.08
CSAC - ***	Page 10.09
CDA - ***	Page 10.11
CDAC - ***	Page 10.11
FQCA - ***	Page 10.14

Instructions for ordering complete cartridge and body assemblies. Page v

Pressure ratings, material specifications. Page 11.02

Ports 1 & 2	ALUMINUM		DUCTILE IRON	
	Part Number		Part Number	
.25 NPTF	GCA		GCA/S	
.375 NPTF	GCB		GCB/S	
SAE-4	GCH		GCH/S	
SAE-6	GCI		GCI/S	
SAE-8	GCJ		GCJ/S	
.25 BSPP	GCT		GCT/S	
.375 BSPP	GCU		GCU/S	

S1
T13A



LINE MOUNT BODIES



- Aluminum rated to 3000 psi.
- Ductile Iron rated to 5000 psi.

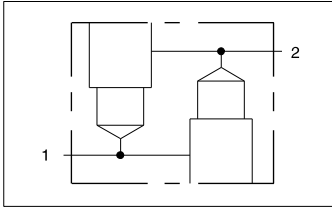

Two cavity inline body.

Mounting Holes:
.34 diameter through hole
2 places.

T-13A Cavity
Locating Shoulder
Depth .03
2 places.

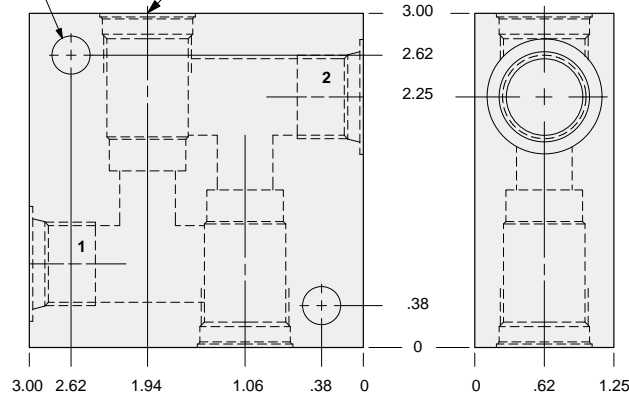

TYPICAL CARTRIDGES USED WITH THIS BODY

- CXDA - *** Page 5.08
NFCC - *** Page 5.12
FXCA - *** Page 5.20

Instructions for ordering complete cartridge and body assemblies. Page v

Pressure ratings, material specifications. Page 11.02

Ports 1 & 2	ALUMINUM		DUCTILE IRON	
	Part Number	List Price	Part Number	List Price
.25 NPTF	XWL		XWL/S	
.375 NPTF	XWM		XWM/S	
SAE-6	XWN		XWN/S	
SAE-8	XWP		XWP/S	
.25 BSPP	XWQ		XWQ/S	
.375 BSPP	XWR		XWR/S	

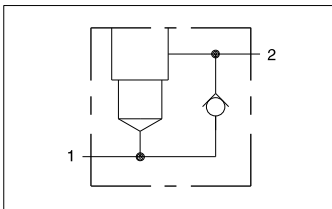

Inline body with reverse free flow check.

T-13A Cavity
Locating Shoulder
Depth .03

Mounting Holes:
.34 diameter through hole
2 places.

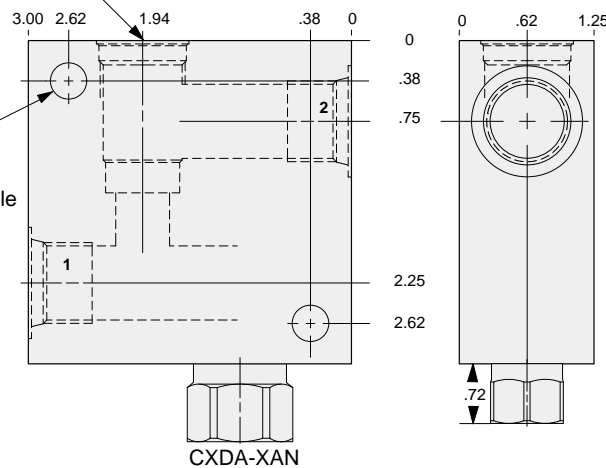

TYPICAL CARTRIDGES USED WITH THIS BODY

- NFCC - *** Page 5.12
FXCA - *** Page 5.20

Cartridge seal type determines check valve seal type.

Instructions for ordering complete cartridge and body assemblies. Page v

Pressure ratings, material specifications. Page 11.02

Ports 1 & 2	ALUMINUM		DUCTILE IRON	
	Part Number	List Price	Part Number	List Price
.25 NPTF	GNL		GNL/S	
.375 NPTF	GNM		GNM/S	
SAE-6	GNN		GNN/S	
SAE-8	GNP		GNP/S	
.25 BSPP	GNQ		GNQ/S	
.375 BSPP	GNR		GNR/S	

S1
T13A



LINE MOUNT BODIES



- Aluminum rated to 3000 psi.
- Ductile Iron rated to 5000 psi.

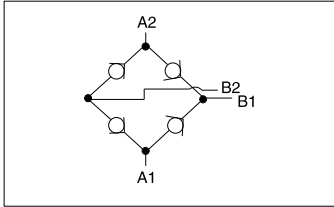
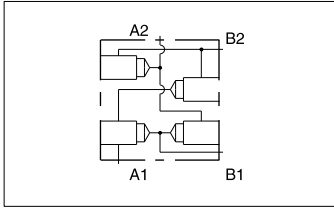

Rectifier body.

Mounting Holes:
 Inch: .375-16 UNC-2B x .62 deep.
 Metric: M10 x 1.50-6H x .62 deep.
 2 places.

T-13A Cavity
 Locating Shoulder
 Depth .03
 4 places.

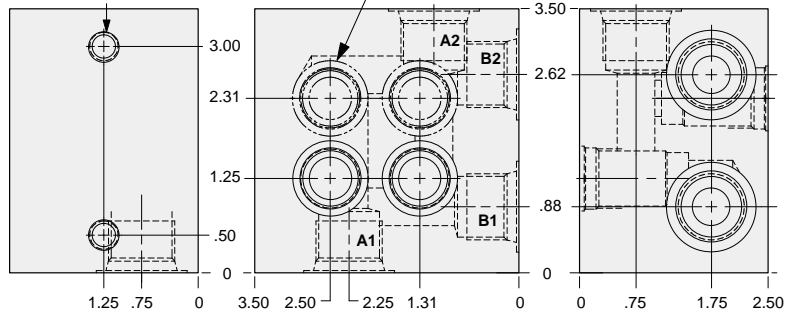

TYPICAL CARTRIDGES USED WITH THIS BODY

CXDA - *** Page 5.08

Instructions for ordering complete cartridge and body assemblies. Page v

Pressure ratings, material specifications. Page 11.02

Mounting Hole Dimensions	Ports 1 & 2	ALUMINUM		DUCTILE IRON	
		Part Number	List Price	Part Number	List Price
Inch	.25 NPTF	YSR		YSR/S	
Inch	.375 NPTF	YSS		YSS/S	
Inch	.50 NPTF	YST		YST/S	
Inch	SAE-6	YSU		YSU/S	
Inch	SAE-8	YSV		YSV/S	
Inch	SAE-10	YSW		YSW/S	
Metric	.25 BSPP	YSX		YSX/S	
Metric	.375 BSPP	YSY		YSY/S	
Metric	.50 BSPP	YSZ		YSZ/S	

S1
T13A



LINE MOUNT BODIES



- Aluminum rated to 3000 psi.
- Ductile Iron rated to 5000 psi.

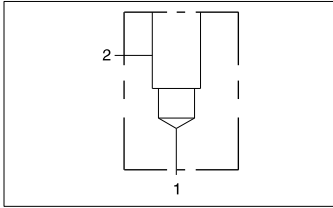

90 degree body.

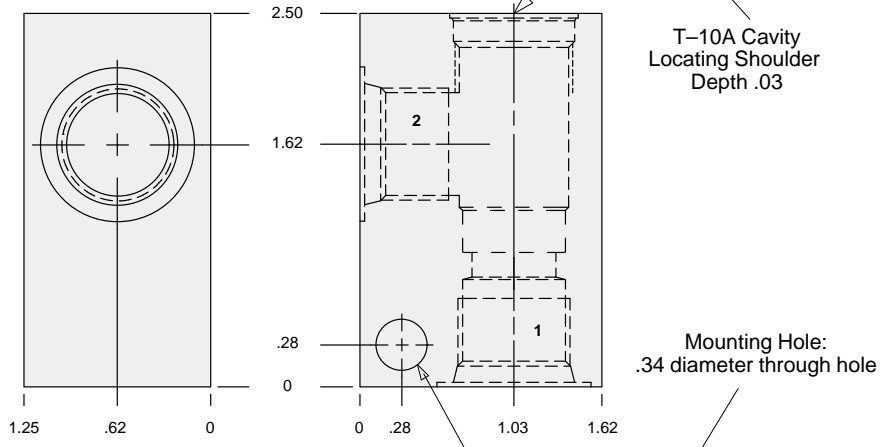

TYPICAL CARTRIDGES USED WITH THIS BODY

RPEC - ***	Page 1.06
RPEE - ***	Page 1.08
RDDA - ***	Page 1.10
RQEB - ***	Page 1.12
RBAC - ***	Page 1.16

Instructions for ordering complete cartridge and body assemblies. Page v

Pressure ratings, material specifications. Page 11.02

Ports 1 & 2	ALUMINUM		DUCTILE IRON	
	Part Number	List Price	Part Number	List Price
.25 NPTF	FAA		FAA/S	
.375 NPTF	FAB		FAB/S	
SAE-4	FAH		FAH/S	
SAE-6	FAI		FAI/S	
SAE-8	FAJ		FAJ/S	
.25 BSPP	FAT		FAT/S	
.375 BSPP	FAU		FAU/S	

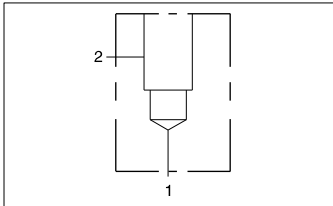

90 degree body.

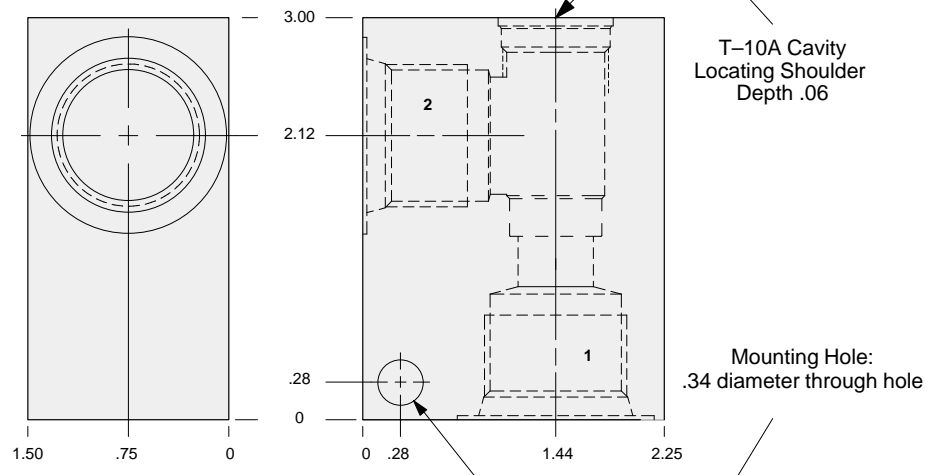

TYPICAL CARTRIDGES USED WITH THIS BODY

RPEC - ***	Page 1.06
RPEE - ***	Page 1.08
RDDA - ***	Page 1.10
RQEB - ***	Page 1.12

Instructions for ordering complete cartridge and body assemblies. Page v

Pressure ratings, material specifications. Page 11.02

Ports 1 & 2	ALUMINUM		DUCTILE IRON	
	Part Number	List Price	Part Number	List Price
.50 NPTF	FAC		FAC/S	
.75 NPTF	FAD		FAD/S	
SAE-10	FAK		FAK/S	
SAE-12	FAL		FAL/S	
.50 BSPP	FAV		FAV/S	
.75 BSPP	FAW		FAW/S	

S1
T10A



LINE MOUNT BODIES



- Aluminum rated to 3000 psi.
- Ductile Iron rated to 5000 psi.

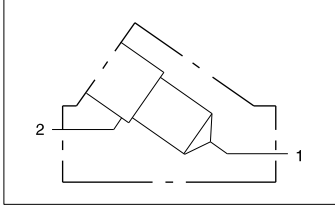

Inline body.

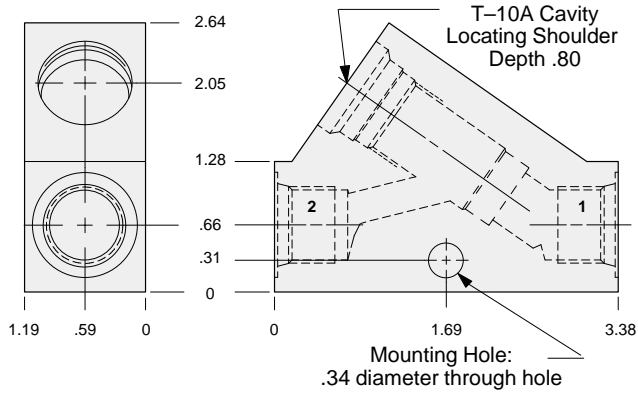

TYPICAL CARTRIDGES USED WITH THIS BODY

RPEC - ***	Page 1.06
RPEE - ***	Page 1.08
RDDA - ***	Page 1.10
RQEB - ***	Page 1.12
RBAC - ***	Page 1.16

Instructions for ordering complete cartridge and body assemblies. Page v

Pressure ratings, material specifications. Page 11.02

Ports 1 & 2	ALUMINUM		DUCTILE IRON	
	Part Number	List Price	Part Number	List Price
.25 NPTF	FCA		FCA/S	
.375 NPTF	FCB		FCB/S	
.50 NPTF	FCC		FCC/S	
SAE-4	FCH		FCH/S	
SAE-6	FCI		FCI/S	
SAE-8	FCJ		FCJ/S	
.25 BSPP	FCT		FCT/S	
.375 BSPP	FCU		FCU/S	
.50 BSPP	FCV		FCV/S	

S1
T10A



LINE MOUNT BODIES



- Aluminum rated to 3000 psi.
- Ductile Iron rated to 5000 psi.

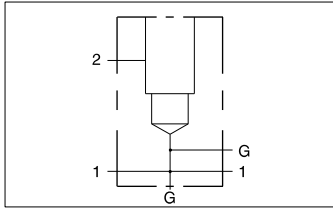

TYPICAL CARTRIDGES USED WITH THIS BODY

RPEC - ***	Page 1.06
RPEE - ***	Page 1.08
RDDA - ***	Page 1.10
RQEB - ***	Page 1.12
RBAC - ***	Page 1.16

Instructions for ordering complete cartridge and body assemblies. Page v

Pressure ratings, material specifications. Page 11.02

Through port body with gage port.

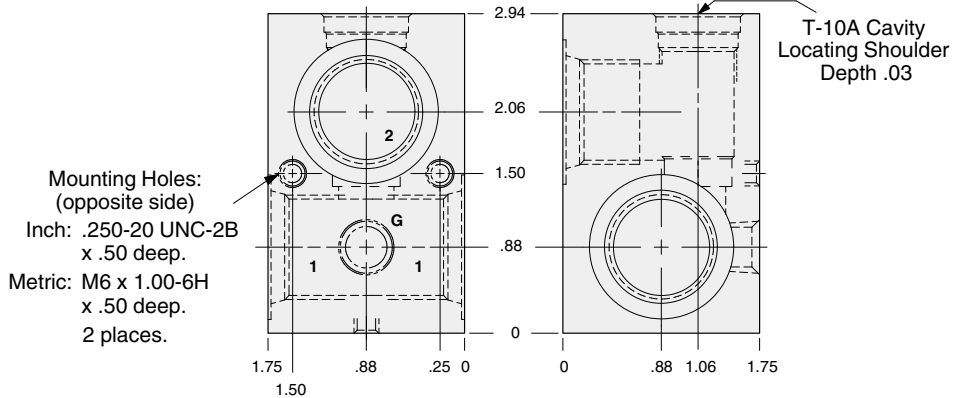

Mounting Hole Dimensions	Ports 1 & 2	Gage Port	ALUMINUM		DUCTILE IRON	
			Part Number	List Price	Part Number	List Price
Inch .25 NPTF	.25 NPTF	.25 NPTF	FEA		FEA/S	
Inch .375 NPTF	.375 NPTF	.25 NPTF	FEB		FEB/S	
Inch .50 NPTF	.50 NPTF	.25 NPTF	FEC		FEC/S	
Inch SAE-6	SAE-6	.25 NPTF	FEI		FEI/S	
Inch SAE-8	SAE-8	.25 NPTF	FEJ		FEJ/S	
Inch SAE-10	SAE-10	.25 NPTF	FEK		FEK/S	
Metric .25 BSPP	.25 BSPP	.25 BSPP	FET		FET/S	
Metric .375 BSPP	.375 BSPP	.25 BSPP	FEU		FEU/S	
Metric .50 BSPP	.50 BSPP	.25 BSPP	FEV		FEV/S	

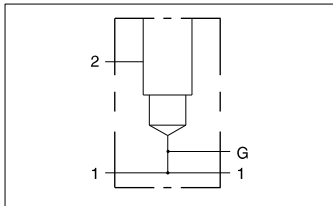

TYPICAL CARTRIDGES USED WITH THIS BODY

RPEC - ***	Page 1.06
RPEE - ***	Page 1.08
RDDA - ***	Page 1.10
RQEB - ***	Page 1.12

Instructions for ordering complete cartridge and body assemblies. Page v

Pressure ratings, material specifications. Page 11.02

Through port body with gage port.

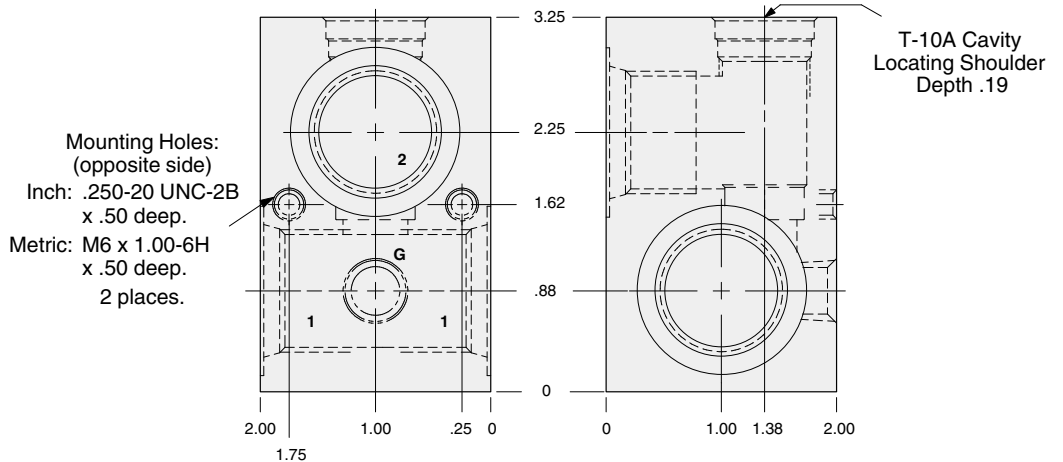

Mounting Hole Dimensions	Ports 1 & 2	Gage Port	ALUMINUM		DUCTILE IRON	
			Part Number	List Price	Part Number	List Price
Inch .75 NPTF	.75 NPTF	.25 NPTF	FED		FED/S	
Inch SAE-12	SAE-12	.25 NPTF	FEL		FEL/S	
Metric .75 BSPP	.75 BSPP	.25 BSPP	FEW		FEW/S	

S1
T10A



LINE MOUNT BODIES



- Aluminum rated to 3000 psi.
- Ductile Iron rated to 5000 psi.

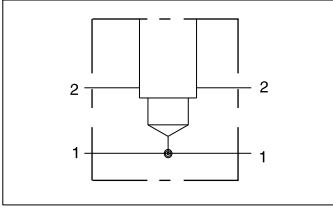

Dual through port body.

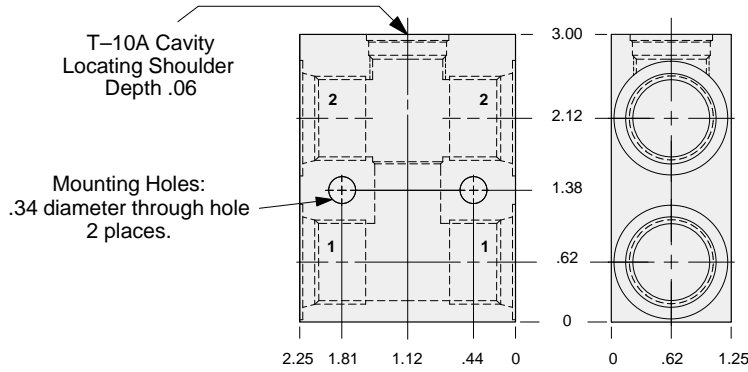

TYPICAL CARTRIDGES USED WITH THIS BODY

RPEC - ***	Page 1.06
RPEE - ***	Page 1.08
RDDA - ***	Page 1.10
RQEB - ***	Page 1.12
RBAC - ***	Page 1.16

Instructions for ordering complete cartridge and body assemblies. Page v

Pressure ratings, material specifications. Page 11.02

Ports 1 & 2	ALUMINUM		DUCTILE IRON	
	Part Number	List Price	Part Number	List Price
.25 NPTF	WNR		WNR/S	
.375 NPTF	WNS		WNS/S	
.50 NPTF	WNT		WNT/S	
SAE-6	WNU		WNU/S	
SAE-8	WNV		WNV/S	
SAE-10	WNW		WNW/S	
.25 BSPP	WNX		WNX/S	
.375 BSPP	WNY		WNY/S	
.50 BSPP	WNZ		WNZ/S	

S1
T10A



LINE MOUNT BODIES



- Aluminum rated to 3000 psi.
- Ductile Iron rated to 5000 psi.

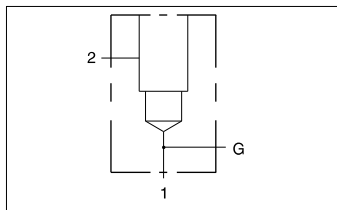

90 degree .75" SAE Code 61 flange port body with gage port.

TYPICAL CARTRIDGES USED WITH THIS BODY

- RPEC - *** Page 1.06
- RPEE - *** Page 1.08
- RDDA - *** Page 1.10
- RQEB - *** Page 1.12

Instructions for ordering complete cartridge and body assemblies. Page v

Pressure ratings, material specifications. Page 11.02

SAE Specifications Page 11.03

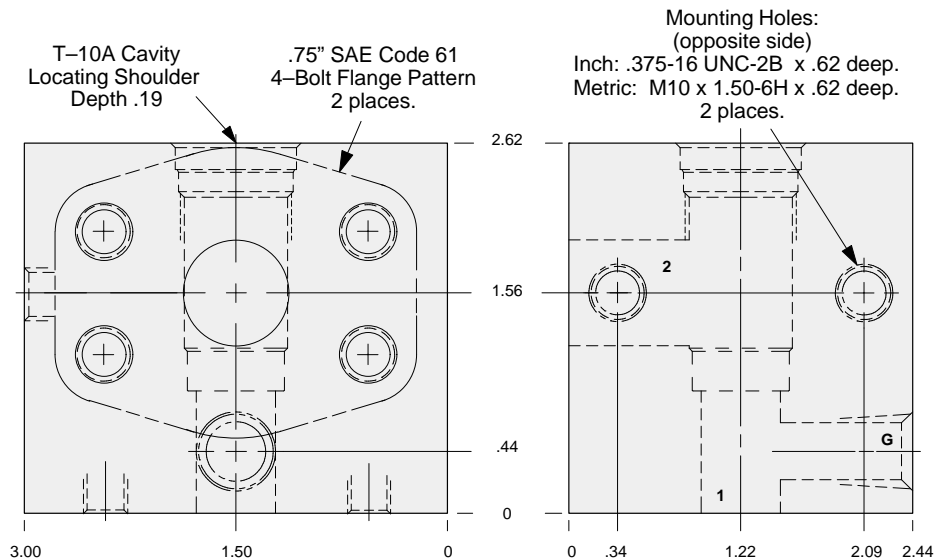

Mounting Hole Dimensions	Gage Port	ALUMINUM		DUCTILE IRON	
		Part Number	List Price	Part Number	List Price
Inch	.25 NPTF	FAO		FAO/S	
Metric	.25 BSPP	FAO/M		FAO/T	

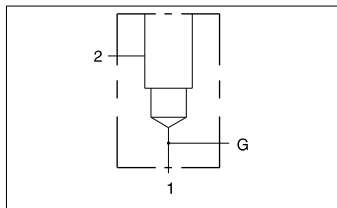

90 degree .75" SAE Code 62 flange port body with gage port.

TYPICAL CARTRIDGES USED WITH THIS BODY

- RPEC - *** Page 1.06
- RPEE - *** Page 1.08
- RDDA - *** Page 1.10
- RQEB - *** Page 1.12

Instructions for ordering complete cartridge and body assemblies. Page v

Pressure ratings, material specifications. Page 11.02

SAE Specifications Page 11.03

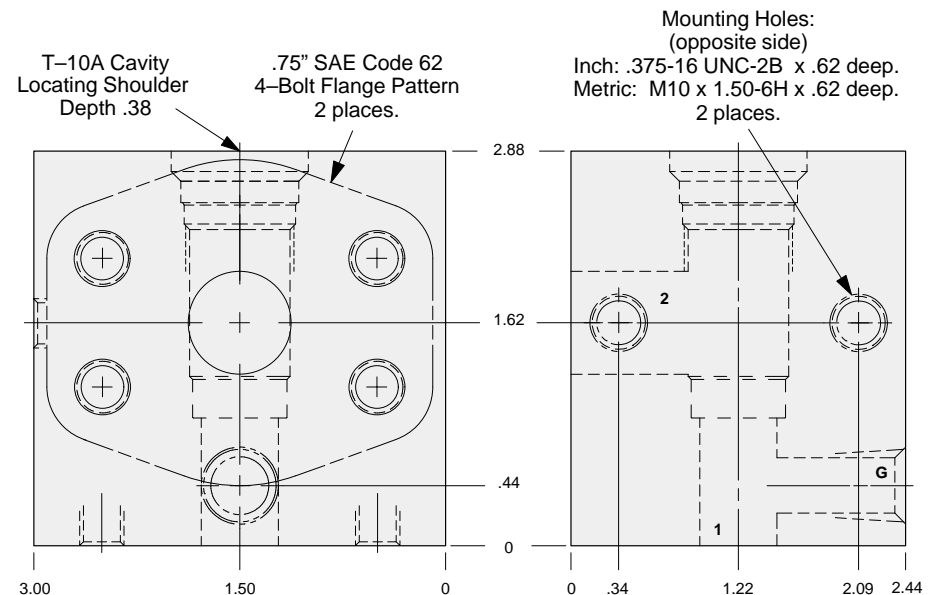

Mounting Hole Dimensions	Gage Port	ALUMINUM		DUCTILE IRON	
		Part Number	List Price	Part Number	List Price
Inch	.25 NPTF	FA3		FA3/S	
Metric	.25 BSPP	FA3/M		FA3/T	

S1
T10A



LINE MOUNT BODIES



- Aluminum rated to 3000 psi.
- Ductile Iron rated to 5000 psi.

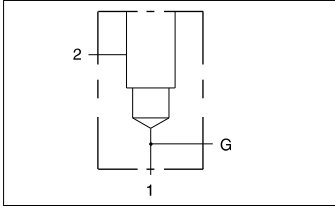

90 degree 1.00" SAE Code 61 flange port body with gage port.

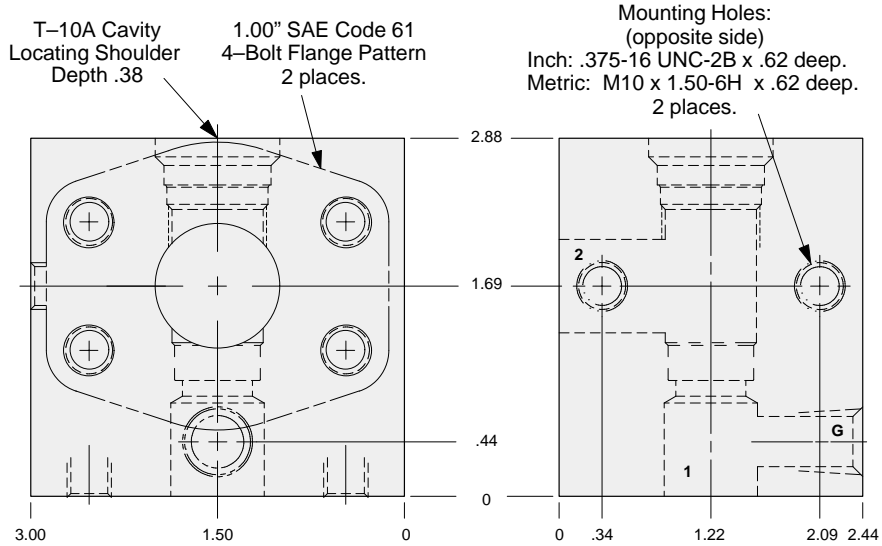

TYPICAL CARTRIDGES USED WITH THIS BODY

- RPEC - *** Page 1.06
RPEE - *** Page 1.08
RDDA - *** Page 1.10
RQEB - *** Page 1.12

Instructions for ordering complete cartridge and body assemblies. Page v

Pressure ratings, material specifications. Page 11.02

SAE Specifications Page 11.03

Mounting Hole Dimensions	Gage Port	ALUMINUM		DUCTILE IRON	
		Part Number	List Price	Part Number	List Price
Inch	.25 NPTF	FAP		FAP/S	
Metric	.25 BSPP	FAP/M		FAP/T	

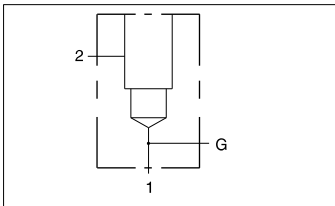

90 degree 1.00" SAE Code 62 flange port body with gage port.

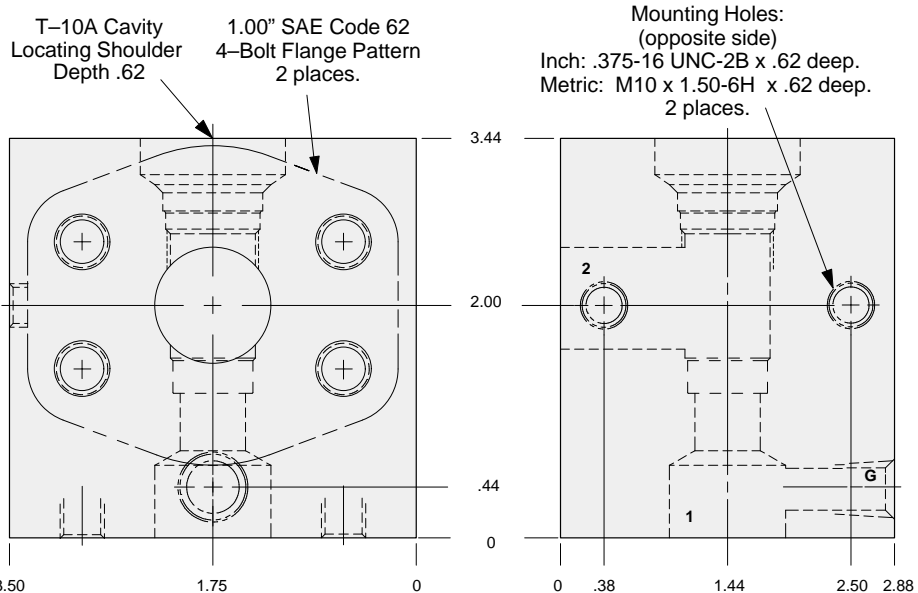

TYPICAL CARTRIDGES USED WITH THIS BODY

- RPEC - *** Page 1.06
RPEE - *** Page 1.08
RDDA - *** Page 1.10
RQEB - *** Page 1.12

Instructions for ordering complete cartridge and body assemblies. Page v

Pressure ratings, material specifications. Page 11.02

SAE Specifications Page 11.03

Mounting Hole Dimensions	Gage Port	ALUMINUM		DUCTILE IRON	
		Part Number	List Price	Part Number	List Price
Inch	.25 NPTF	FA4		FA4/S	
Metric	.25 BSPP	FA4/M		FA4/T	

S1
T10A



LINE MOUNT BODIES



- Aluminum rated to 3000 psi.
- Ductile Iron rated to 5000 psi.

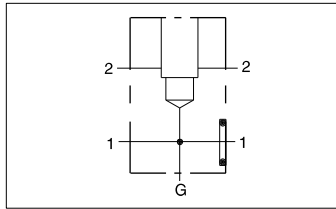

TYPICAL CARTRIDGES USED WITH THIS BODY

- RPEC - *** Page 1.06
- RPEE - *** Page 1.08
- RDDA - *** Page 1.10
- RQEB - *** Page 1.12

Cartridge seal type determines O-ring type.

Instructions for ordering complete cartridge and body assemblies. Page v

Pressure ratings, material specifications. Page 11.02

SAE Specifications Page 11.03

Sandwich mount through port .75" SAE Code 61 body with gage port.

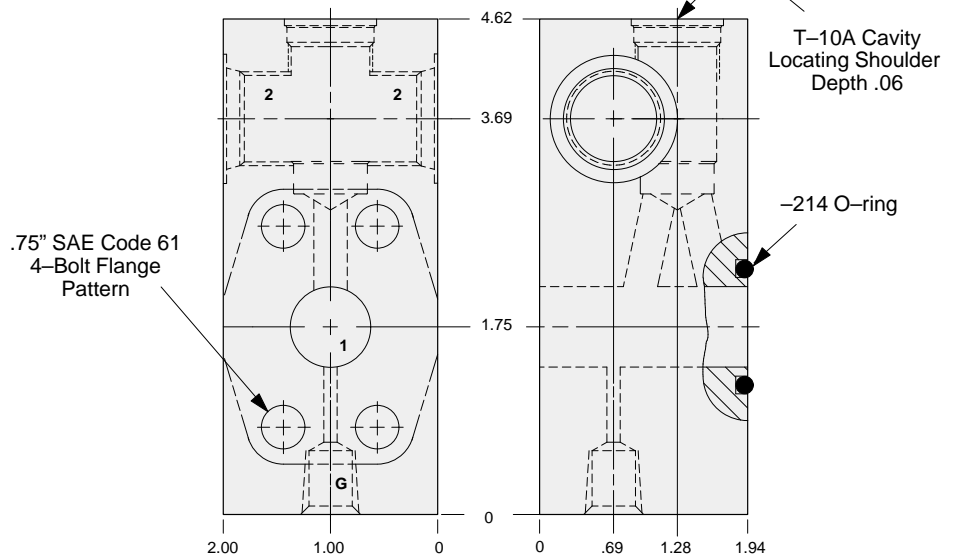

Mounting Hole Dimensions	Port 2	Gage Port	ALUMINUM		DUCTILE IRON	
			Part Number	List Price	Part Number	List Price
Inch	SAE-10	.25 NPTF	ZQN		ZQN/S	
Metric	.50 BSPP	.25 BSPP	ZQM		ZQM/S	

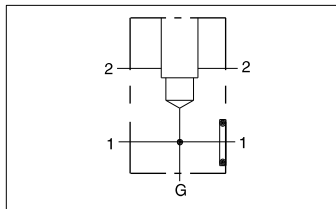

TYPICAL CARTRIDGES USED WITH THIS BODY

- RPEC - *** Page 1.06
- RPEE - *** Page 1.08
- RDDA - *** Page 1.10
- RQEB - *** Page 1.12

Cartridge seal type determines O-ring type.

Instructions for ordering complete cartridge and body assemblies. Page v

Pressure ratings, material specifications. Page 11.02

SAE Specifications Page 11.03

Flange mount through port .75" SAE Code 61 body with threaded outlet and gage port.

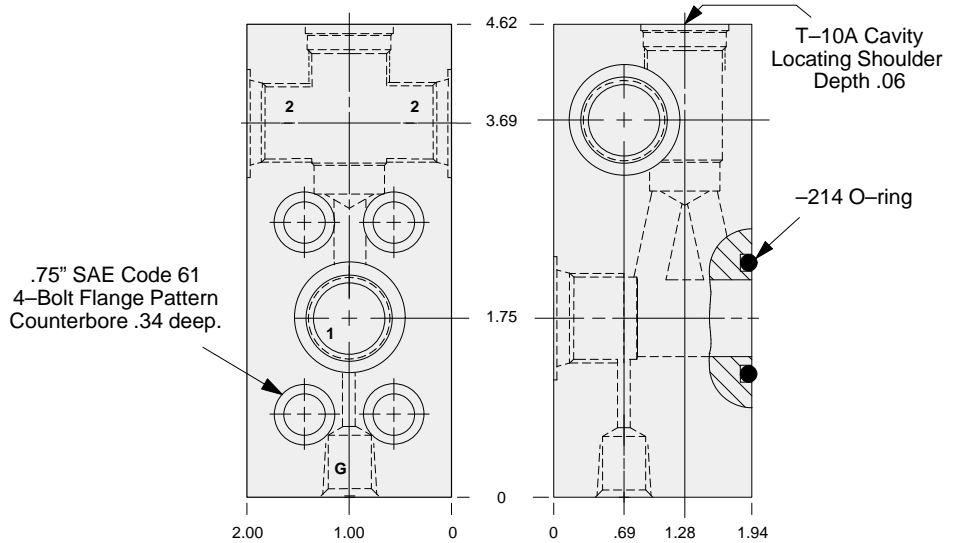

Mounting Hole Dimensions	Ports 1 & 2	Gage Port	ALUMINUM		DUCTILE IRON	
			Part Number	List Price	Part Number	List Price
Inch	SAE-10	.25 NPTF	ZDG		ZDG/S	
Inch	.50 NPTF	.25 NPTF	ZDJ		ZDJ/S	
Metric	.50 BSPP	.25 BSPP	ZDD		ZDD/S	

S1
T10A



LINE MOUNT BODIES



- Aluminum rated to 3000 psi.
- Ductile Iron rated to 5000 psi.

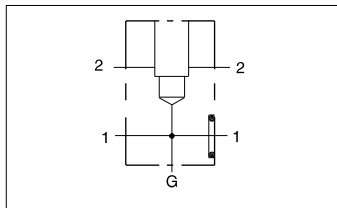

Sandwich mount through port .75" SAE Code 61 body with gage port.

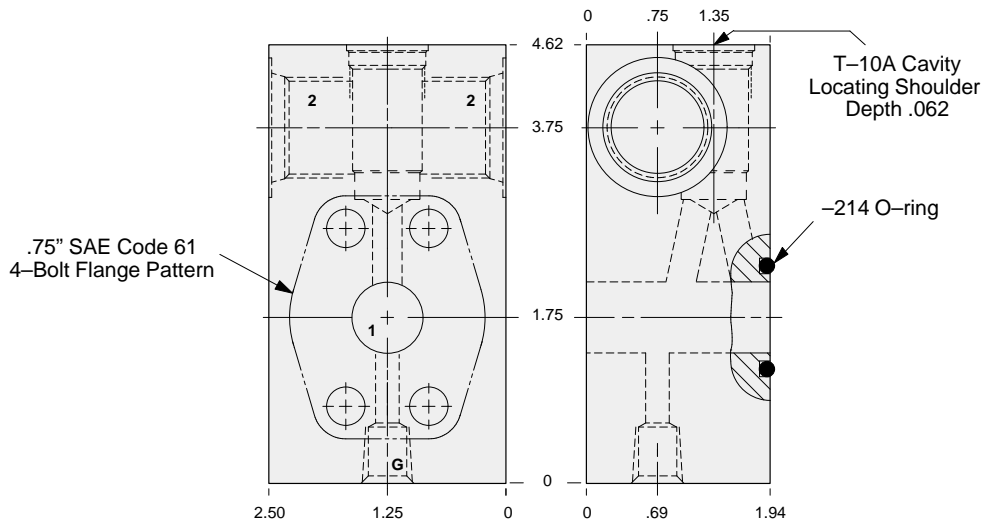

TYPICAL CARTRIDGES USED WITH THIS BODY

- RPEC - *** Page 1.06
- RPEE - *** Page 1.08
- RDDA - *** Page 1.10
- RQEB - *** Page 1.12

Cartridge seal type determines O-ring type.

Instructions for ordering complete cartridge and body assemblies. Page v

Pressure ratings, material specifications. Page 11.02

SAE Specifications Page 11.03

Mounting Hole Dimensions	Port 2	Gage Port	ALUMINUM		DUCTILE IRON	
			Part Number	List Price	Part Number	List Price
Inch	SAE-12	.25 NPTF	ZHB		ZHB/S	
Inch	.75 NPTF	.25 NPTF	ZHC		ZHC/S	
Metric	.75 BSPP	.25 BSPP	ZGZ		ZGZ/S	

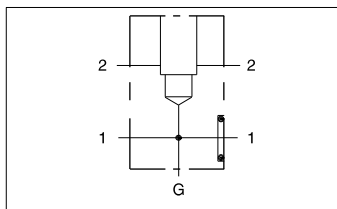

Sandwich mount through port .75" SAE Code 62 body with gage port.

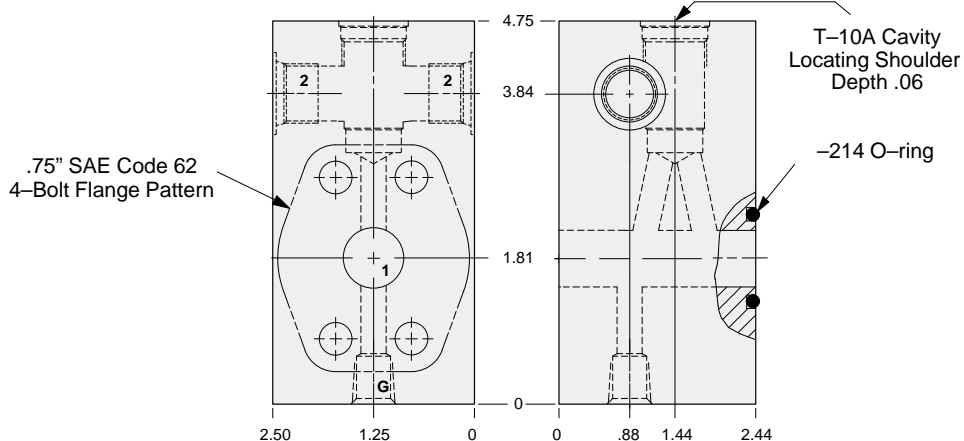

TYPICAL CARTRIDGES USED WITH THIS BODY

- RPEC - *** Page 1.06
- RPEE - *** Page 1.08
- RDDA - *** Page 1.10
- RQEB - *** Page 1.12

Cartridge seal type determines O-ring type.

Instructions for ordering complete cartridge and body assemblies. Page v

Pressure ratings, material specifications. Page 11.02

SAE Specifications Page 11.03

Mounting Hole Dimensions	Port 2	Gage Port	ALUMINUM		DUCTILE IRON	
			Part Number	List Price	Part Number	List Price
Inch	SAE-12	.25 NPTF	ZCW		ZCW/S	
Inch	SAE-10	.25 NPTF	ZCX		ZCX/S	
Inch	.75 NPTF	.25 NPTF	ZCY		ZCY/S	
Inch	.50 NPTF	.25 NPTF	ZCZ		ZCZ/S	
Metric	.75 BSPP	.25 BSPP	ZCT		ZCT/S	
Metric	.50 BSPP	.25 BSPP	ZCV/M		ZCV/T	

S1
T10A



LINE MOUNT BODIES



- Aluminum rated to 3000 psi.
- Ductile Iron rated to 5000 psi.

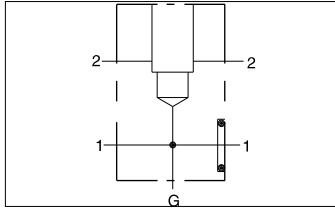

TYPICAL CARTRIDGES USED WITH THIS BODY

- RPEC - *** Page 1.06
- RPEE - *** Page 1.08
- RDDA - *** Page 1.10
- RQEB - *** Page 1.12

Cartridge seal type determines O-ring type.

Instructions for ordering complete cartridge and body assemblies. Page v

Pressure ratings, material specifications. Page 11.02

SAE Specifications Page 11.03

Flange mount through port .75" SAE Code 61 body with threaded outlet and gage port.

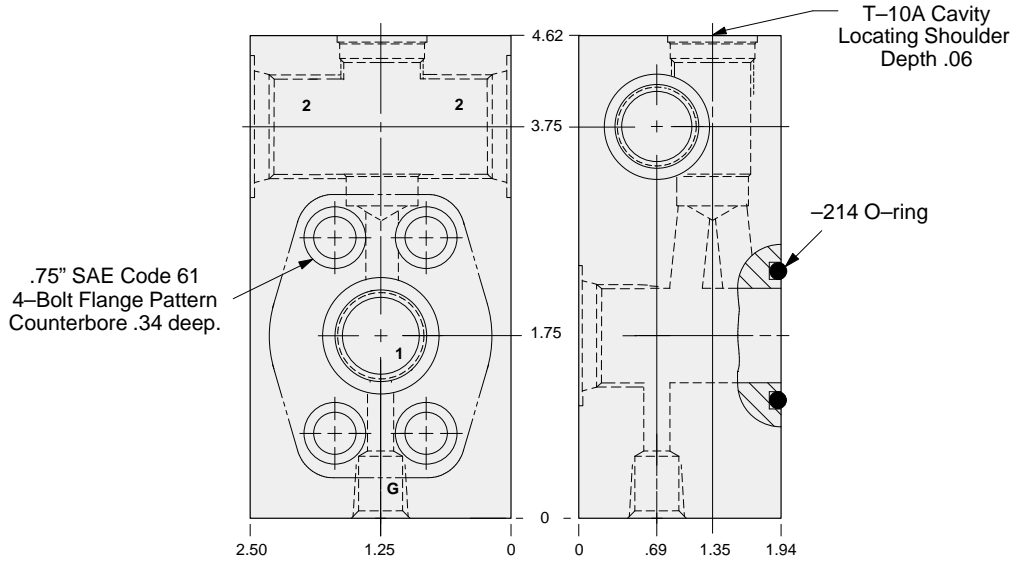

Mounting Hole Dimensions	Ports 1 & 2	Gage Port	ALUMINUM		DUCTILE IRON	
			Part Number	List Price	Part Number	List Price
Inch	SAE-12	.25 NPTF	ZDF		ZDF/S	
Inch	.75 NPTF	.25 NPTF	ZDH		ZDH/S	
Metric	.75 BSPP	.25 BSPP	ZDC		ZDC/S	

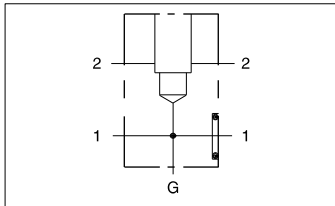

TYPICAL CARTRIDGES USED WITH THIS BODY

- RPEC - *** Page 1.06
- RPEE - *** Page 1.08
- RDDA - *** Page 1.10
- RQEB - *** Page 1.12

Cartridge seal type determines O-ring type.

Instructions for ordering complete cartridge and body assemblies. Page v

Pressure ratings, material specifications. Page 11.02

SAE Specifications Page 11.03

Flange mount through port .75" SAE Code 62 body with threaded outlet and gage port.

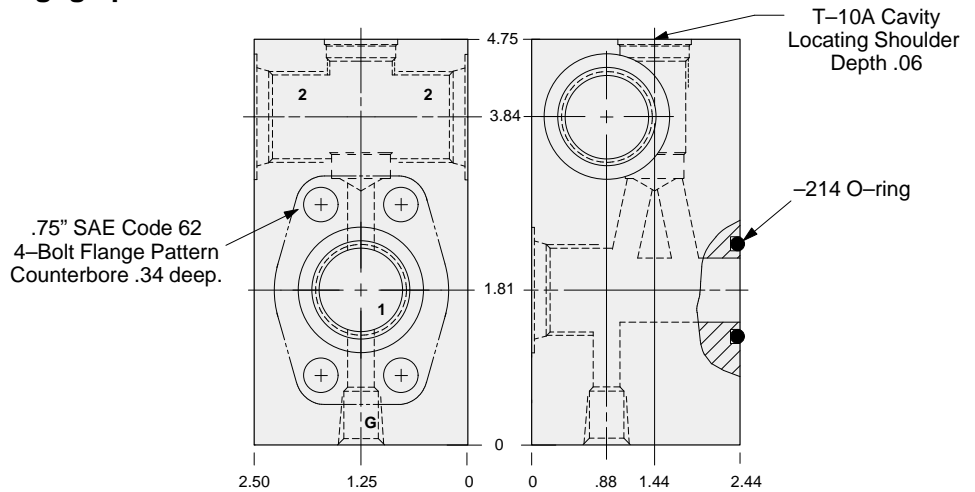

Mounting Hole Dimensions	Ports 1 & 2	Gage Port	ALUMINUM		DUCTILE IRON	
			Part Number	List Price	Part Number	List Price
Inch	SAE-12	.25 NPTF	ZCP		ZCP/S	
Inch	SAE-10	.25 NPTF	ZCQ		ZCQ/S	
Inch	.75 NPTF	.25 NPTF	ZCR		ZCR/S	
Inch	.50 NPTF	.25 NPTF	ZCS		ZCS/S	
Metric	.75 BSPP	.25 BSPP	ZCM		ZCM/S	
Metric	.50 BSPP	.25 BSPP	ZCN		ZCN/S	

S1
T10A



LINE MOUNT BODIES



- Aluminum rated to 3000 psi.
- Ductile Iron rated to 5000 psi.

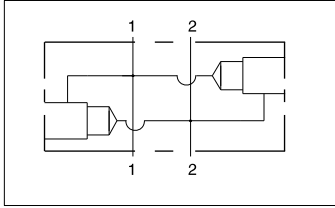

TYPICAL CARTRIDGES USED WITH THIS BODY

- RPEC - *** Page 1.06
- RPEE - *** Page 1.08
- RDDA - *** Page 1.10
- RQEB - *** Page 1.12

Instructions for ordering complete cartridge and body assemblies. Page v

Pressure ratings, material specifications. Page 11.02

Two cavity body for cross-port relief applications.

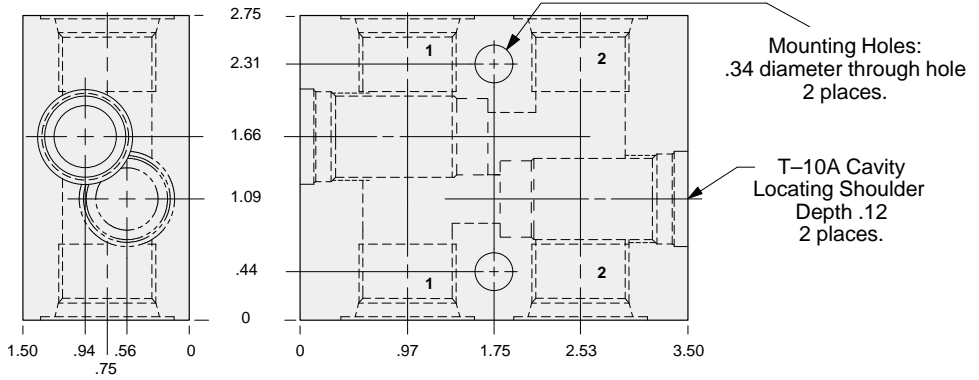

Ports 1 & 2	ALUMINUM		DUCTILE IRON	
	Part Number	List Price	Part Number	List Price
.25 NPTF	YFA		YFA/S	
.375 NPTF	YFB		YFB/S	
.50 NPTF	YFC		YFC/S	
SAE-4	YFH		YFH/S	
SAE-6	YFI		YFI/S	
SAE-8	YFJ		YFJ/S	
SAE-10	YFK		YFK/S	
.25 BSPP	YFT		YFT/S	
.375 BSPP	YFU		YFU/S	
.50 BSPP	YFV		YFV/S	

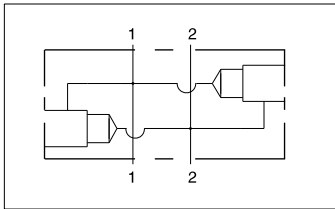

TYPICAL CARTRIDGES USED WITH THIS BODY

- RPEC - *** Page 1.06
- RPEE - *** Page 1.08
- RDDA - *** Page 1.10
- RQEB - *** Page 1.12

Instructions for ordering complete cartridge and body assemblies. Page v

Pressure ratings, material specifications. Page 11.02

Two cavity body for cross-port relief applications.

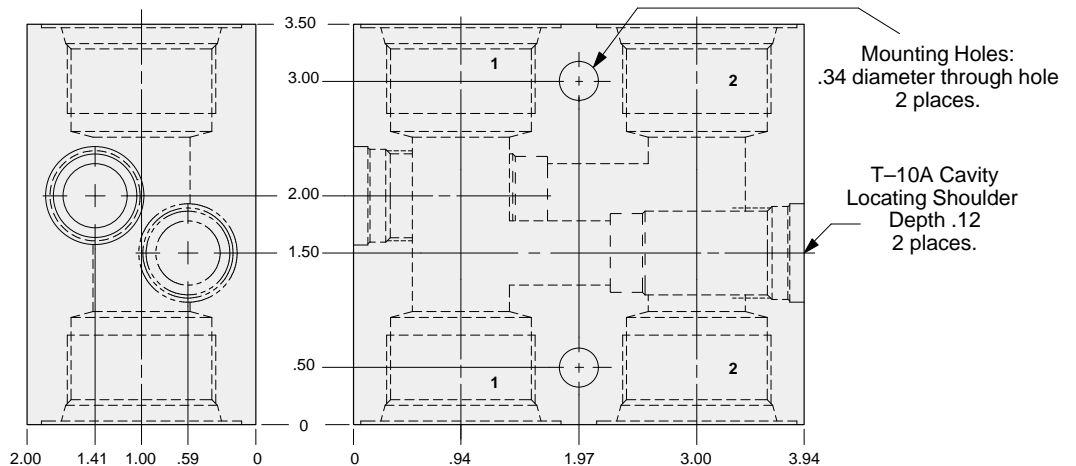

Ports 1 & 2	ALUMINUM		DUCTILE IRON	
	Part Number	List Price	Part Number	List Price
.75 NPTF	YFD		YFD/S	
1.00 NPTF	YFE		YFE/S	
SAE-12	YFL		YFL/S	
SAE-16	YFM		YFM/S	
.75 BSPP	YFW		YFW/S	
1.00 BSPP	YFX		YFX/S	

S1
T10A



LINE MOUNT BODIES



- Aluminum rated to 3000 psi.
- Ductile Iron rated to 5000 psi.

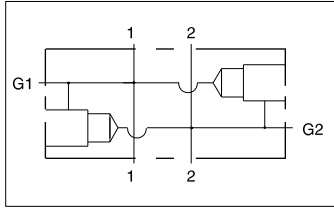

Two cavity .75" SAE Code 61 flange port body for cross-port relief applications.

TYPICAL CARTRIDGES USED WITH THIS BODY

- RPEC - *** Page 1.06
- RPEE - *** Page 1.08
- RDDA - *** Page 1.10
- RQEB - *** Page 1.12

Instructions for ordering complete cartridge and body assemblies. Page v

Pressure ratings, material specifications. Page 11.02

SAE Specifications Page 11.03

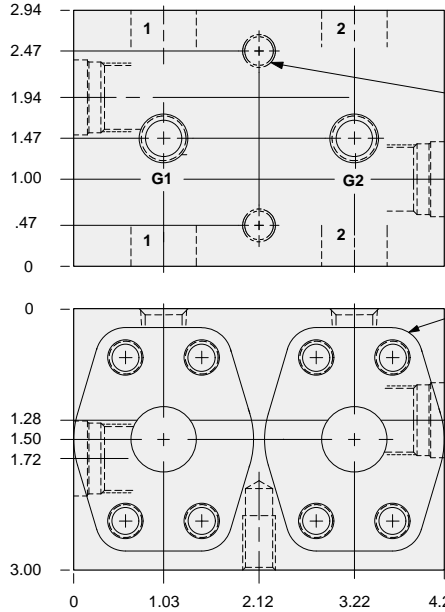

Mounting Holes:
(opposite side)
Inch: .375-16 UNC-2B x .62 deep
Metric: M10 x 1.50-6H x .62 deep
2 places.

.75" SAE Code 61
4-Bolt Flange Pattern
4 places.

T-10A Cavity
Locating Shoulder
Depth .16
2 places.

Mounting Hole Dimensions	Ports G1 & G2	ALUMINUM		DUCTILE IRON	
		Part Number	List Price	Part Number	List Price
Inch	.25 NPTF	YFO		YFO/S	
Metric	.25 BSPP	YFO/M		YFO/T	

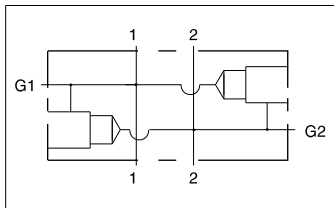

Two cavity .75" SAE Code 62 flange port body for cross-port relief applications.

TYPICAL CARTRIDGES USED WITH THIS BODY

- RPEC - *** Page 1.06
- RPEE - *** Page 1.08
- RDDA - *** Page 1.10
- RQEB - *** Page 1.12

Instructions for ordering complete cartridge and body assemblies. Page v

Pressure ratings, material specifications. Page 11.02

SAE Specifications Page 11.03

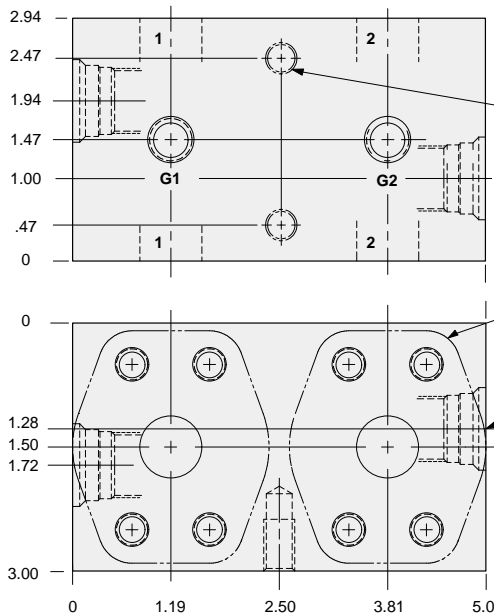

Mounting Holes:
(opposite side)
Inch: .375-16 UNC-2B x .62 deep
Metric: M10 x 1.50-6H x .62 deep
2 places.

.75" SAE Code 62
4-Bolt Flange Pattern
4 places.

T-10A Cavity
Locating Shoulder
Depth .31
2 places.

Mounting Hole Dimensions	Ports G1 & G2	ALUMINUM		DUCTILE IRON	
		Part Number	List Price	Part Number	List Price
Inch	.25 NPTF	YF3		YF3/S	
Metric	.25 BSPP	YF3/M		YF3/T	

S1
T10A



LINE MOUNT BODIES

- Aluminum rated to 3000 psi.
- Ductile Iron rated to 5000 psi.

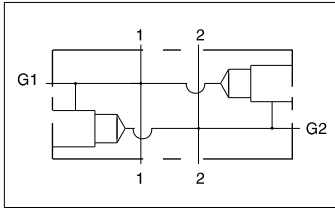

TYPICAL CARTRIDGES USED WITH THIS BODY

- RPEC - *** Page 1.06
 RPEE - *** Page 1.08
 RDDA - *** Page 1.10
 RQEB - *** Page 1.12

Instructions for ordering complete cartridge and body assemblies. Page v

Pressure ratings, material specifications. Page 11.02

SAE Specifications Page 11.03

Two cavity 1.00" SAE Code 61 flange port body with gage port for cross-port relief applications.

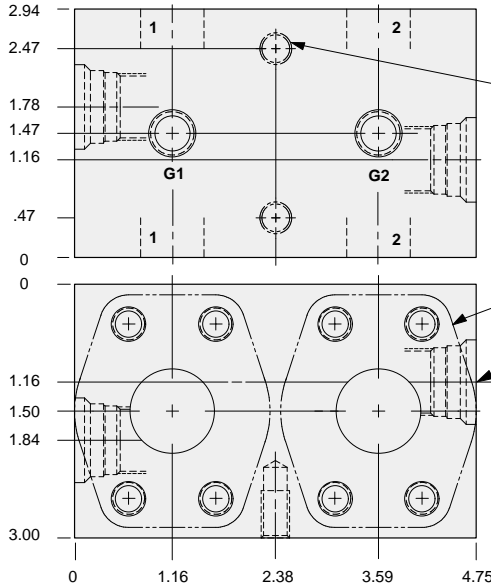

Mounting Holes:
 (opposite side)
 Inch: .375-16 UNC-2B x .62 deep
 Metric: M10 x 1.50-6H x .62 deep
 2 places.

1.00" SAE Code 61
 4-Bolt Flange Pattern
 4 places.

T-10A Cavity
 Locating Shoulder
 Depth .34
 2 places.

Mounting Hole Dimensions	Ports G1 & G2	ALUMINUM		DUCTILE IRON	
		Part Number	List Price	Part Number	List Price
Inch	.25 NPTF	YFP		YFP/S	
Metric	.25 BSPP	YFP/M		YFP/T	

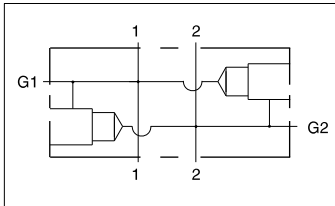

TYPICAL CARTRIDGES USED WITH THIS BODY

- RPEC - *** Page 1.06
 RPEE - *** Page 1.08
 RDDA - *** Page 1.10
 RQEB - *** Page 1.12

Instructions for ordering complete cartridge and body assemblies. Page v

Pressure ratings, material specifications. Page 11.02

SAE Specifications Page 11.03

Two cavity 1.00" SAE Code 62 flange port body with gage port for cross-port relief applications.

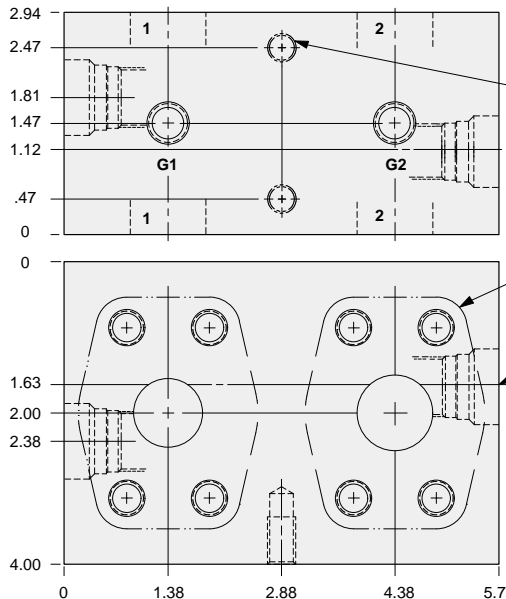

Mounting Holes:
 (opposite side)
 Inch: .375-16 UNC-2B x .62 deep
 Metric: M10 x 1.50-6H x .62 deep
 2 places.

1.00" SAE Code 62
 4-Bolt Flange Pattern
 4 places.

T-10A Cavity
 Locating Shoulder
 Depth .56
 2 places.

Mounting Hole Dimensions	Ports G1 & G2	ALUMINUM		DUCTILE IRON	
		Part Number	List Price	Part Number	List Price
Inch	.25 NPTF	YF4		YF4/S	
Metric	.25 BSPP	YF4/M		YF4/T	



LINE MOUNT BODIES



- Aluminum rated to 3000 psi.
- Ductile Iron rated to 5000 psi.

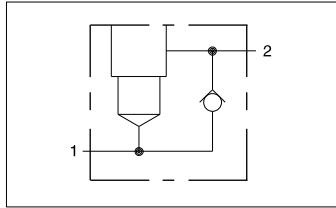

Body with reverse free flow check.

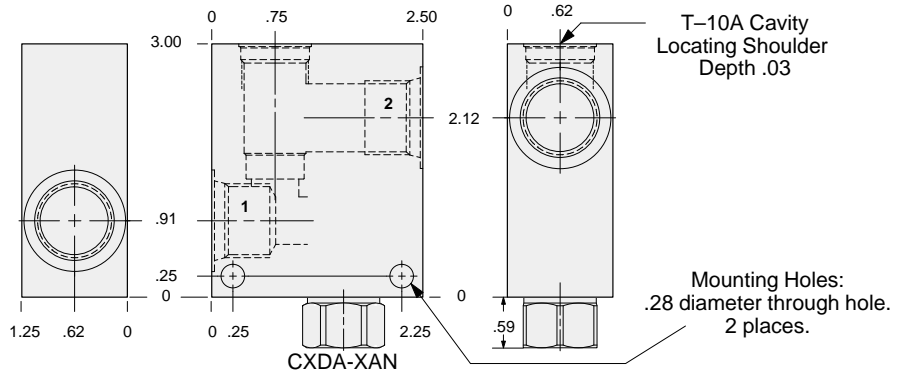

TYPICAL CARTRIDGES USED WITH THIS BODY

RPEC - ***	Page 1.06
RPEE - ***	Page 1.08
RDDA - ***	Page 1.10
RQEB - ***	Page 1.12
RBAC - ***	Page 1.16

Cartridge seal type determines check valve seal type.

Instructions for ordering complete cartridge and body assemblies. Page v

Pressure ratings, material specifications. Page 11.02

Ports 1 & 2	ALUMINUM		DUCTILE IRON	
	Part Number	List Price	Part Number	List Price
.25 NPTF	FNA		FNA/S	
.375 NPTF	FNB		FNB/S	
.50 NPTF	FNC		FNC/S	
SAE-6	FNI		FNI/S	
SAE-8	FNJ		FNJ/S	
SAE-10	FNK		FNK/S	
.25 BSPP	FNT		FNT/S	
.375 BSPP	FNU		FNU/S	
.50 BSPP	FNV		FNV/S	

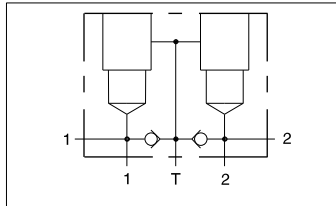

Two cavity body with make-up checks for cross-port relief applications.

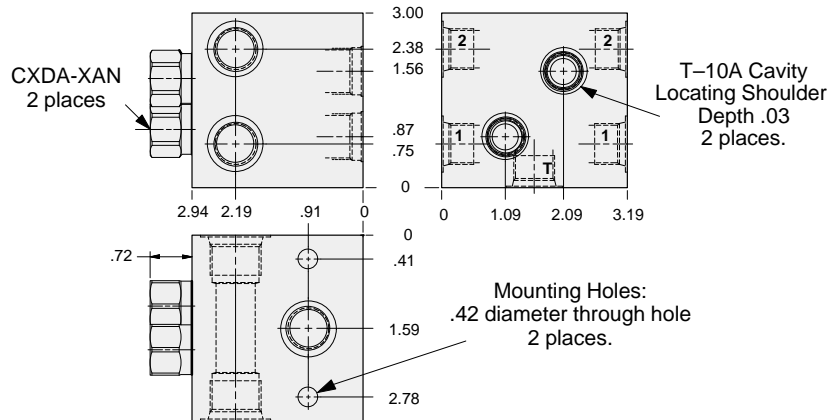

TYPICAL CARTRIDGES USED WITH THIS BODY

RPEC - ***	Page 1.06
RPEE - ***	Page 1.08
RDDA - ***	Page 1.10
RQEB - ***	Page 1.12

Cartridge seal type determines check valve seal type.

Instructions for ordering complete cartridge and body assemblies. Page v

Pressure ratings, material specifications. Page 11.02

Ports 1 & 2 & T	ALUMINUM		DUCTILE IRON	
	Part Number	List Price	Part Number	List Price
.25 NPTF	FMA		FMA/S	
.375 NPTF	FMB		FMB/S	
.50 NPTF	FMC		FMC/S	
SAE-6	FMI		FMI/S	
SAE-8	FMJ		FMJ/S	
SAE-10	FMK		FMK/S	
.25 BSPP	FMT		FMT/S	
.375 BSPP	FMU		FMU/S	
.50 BSPP	FMV		FMV/S	

S1
T10A



LINE MOUNT BODIES



- Aluminum rated to 3000 psi.
- Ductile Iron rated to 5000 psi.

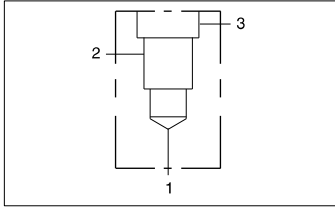

90 degree body.

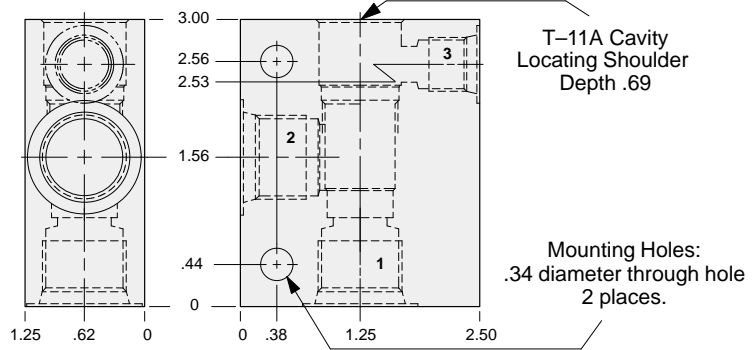

TYPICAL CARTRIDGES USED WITH THIS BODY

RBAD - ***	Page 1.17
RVCA - ***	Page 1.18
RSDC - ***	Page 2.06
SQDB - ***	Page 2.08
SCCA - ***	Page 2.12
PBDB - ***	Page 3.06
CBCA - ***	Page 4.10
CBCG - ***	Page 4.12
CBCH - ***	Page 4.14
CKCB - ***	Page 4.16
LODC - ***	Page 9.08
LKDC - ***	Page 9.10
LPDC - ***	Page 9.12
LRDC - ***	Page 9.14
CSAB - ***	Page 10.08
CDAB - ***	Page 10.10
CODA - ***	Page 10.12

Instructions for ordering complete cartridge and body assemblies. Page v

Pressure ratings, material specifications. Page 11.02

Ports 1 & 2	Port 3	ALUMINUM		DUCTILE IRON	
		Part Number	List Price	Part Number	List Price
.25 NPTF	.25 NPTF	ECA		ECA/S	
.375 NPTF	.25 NPTF	ECB		ECB/S	
.50 NPTF	.25 NPTF	ECC		ECC/S	
SAE-4	SAE-4	ECH		ECH/S	
SAE-6	SAE-6	ECI		ECI/S	
SAE-8	SAE-6	ECJ		ECJ/S	
SAE-10	SAE-6	ECK		ECK/S	
.25 BSPP	.25 BSPP	ECT		ECT/S	
.375 BSPP	.25 BSPP	ECU		ECU/S	
.50 BSPP	.25 BSPP	ECV		ECV/S	

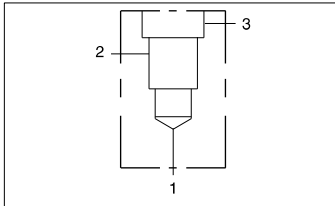

90 degree body with high capacity port 3.

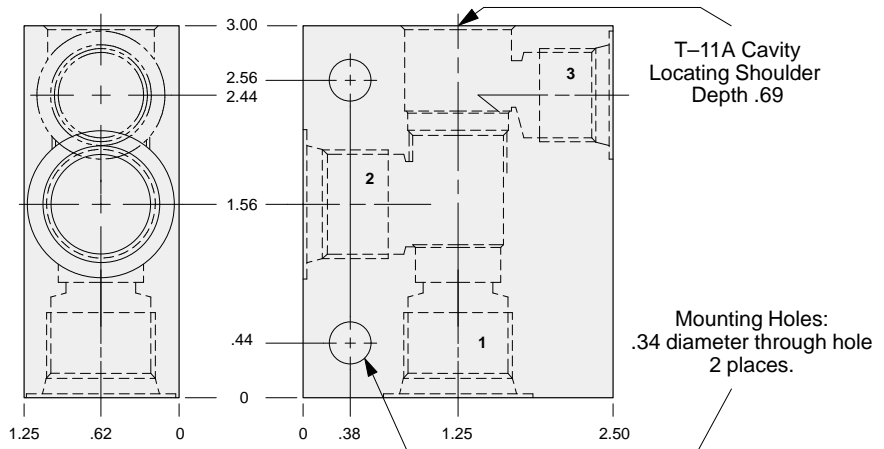

TYPICAL CARTRIDGES USED WITH THIS BODY

PPDB - ***	Page 3.10
FRCA - ***	Page 6.02
DPBA - ***	Page 8.06
DPBB - ***	Page 8.07
DPBC - ***	Page 8.08
DPBD - ***	Page 8.09

Instructions for ordering complete cartridge and body assemblies. Page v

Pressure ratings, material specifications. Page 11.02

Ports 1 & 2	Port 3	ALUMINUM		DUCTILE IRON	
		Part Number	List Price	Part Number	List Price
.375 NPTF	.375 NPTF	EAB		EAB/S	
.50 NPTF	.375 NPTF	EAC		EAC/S	
SAE-8	SAE-8	EAJ		EAJ/S	
SAE-10	SAE-8	EAK		EAK/S	
.375 BSPP	.375 BSPP	EAU		EAU/S	
.50 BSPP	.375 BSPP	EAV		EAV/S	

S1
T11A



LINE MOUNT BODIES



- Aluminum rated to 3000 psi.
- Ductile Iron rated to 5000 psi.

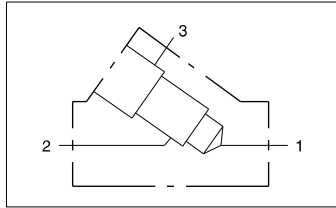

Inline body.

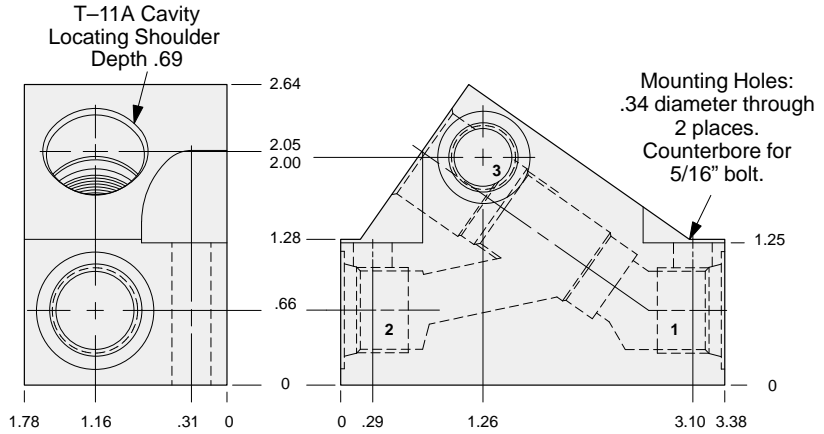

TYPICAL CARTRIDGES USED WITH THIS BODY

RBAD - ***	Page 1.17
RVCA - ***	Page 1.18
RSDC - ***	Page 2.06
SQDB - ***	Page 2.08
SCCA - ***	Page 2.12
PBDB - ***	Page 3.06
CBCA - ***	Page 4.10
CBCG - ***	Page 4.12
CBCH - ***	Page 4.14
CKCB - ***	Page 4.16
LODC - ***	Page 9.08
LKDC - ***	Page 9.10
LPDC - ***	Page 9.12
LRDC - ***	Page 9.14
CSAB - ***	Page 10.08
CDAB - ***	Page 10.10
CODA - ***	Page 10.12

Instructions for ordering complete cartridge and body assemblies. Page v

Pressure ratings, material specifications. Page 11.02

Ports 1 & 2	Port 3	ALUMINUM		DUCTILE IRON	
		Part Number	List Price	Part Number	List Price
.25 NPTF	.25 NPTF	EJA		EJA/S	
.375 NPTF	.25 NPTF	EJB		EJB/S	
SAE-8	SAE-8	EJI		EJI/S	
SAE-8	SAE-8	EJJ		EJJ/S	
.25 BSPP	.25 BSPP	EJT		EJT/S	
.375 BSPP	.25 BSPP	EJU		EJU/S	
.50 BSPP	.25 BSPP	EJV		EJV/S	

S1
T11A



LINE MOUNT BODIES



- Aluminum rated to 3000 psi.
- Ductile Iron rated to 5000 psi.

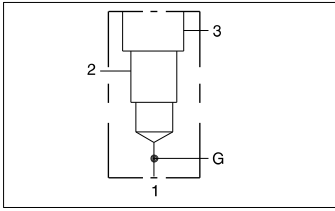

90 degree body with gage port.

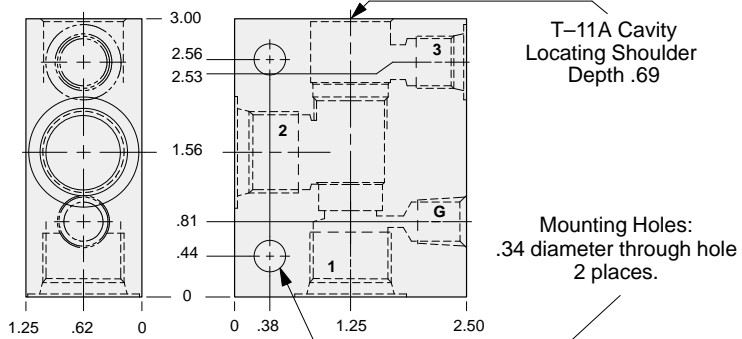

TYPICAL CARTRIDGES USED WITH THIS BODY

RBAD - ***	Page 1.17
RVCA - ***	Page 1.18
RSDC - ***	Page 2.06
SQDB - ***	Page 2.08
SCCA - ***	Page 2.12
PBDB - ***	Page 3.06
LODC - ***	Page 9.08
LKDC - ***	Page 9.10
LPDC - ***	Page 9.12
LRDC - ***	Page 9.14
CSAB - ***	Page 10.08
CDAB - ***	Page 10.10
CODA - ***	Page 10.12

Instructions for ordering complete cartridge and body assemblies. Page v

Pressure ratings, material specifications. Page 11.02

Ports 1 & 2	Port 3	Gage Port	ALUMINUM		DUCTILE IRON	
			Part Number	List Price	Part Number	List Price
.25 NPTF	.25 NPTF	.25 NPTF	EFA		EFA/S	
.375 NPTF	.25 NPTF	.25 NPTF	EFB		EFB/S	
.50 NPTF	.25 NPTF	.25 NPTF	EFC		EFC/S	
SAE-4	SAE-4	.25 NPTF	EFH		EFH/S	
SAE-6	SAE-6	.25 NPTF	EFI		EFI/S	
SAE-8	SAE-6	.25 NPTF	EFJ		EFJ/S	
SAE-10	SAE-6	.25 NPTF	EFK		EFK/S	
.25 BSPP	.25 BSPP	.25 BSPP	EFT		EFT/S	
.375 BSPP	.25 BSPP	.25 BSPP	EFU		EFU/S	
.50 BSPP	.25 BSPP	.25 BSPP	EFV		EFV/S	

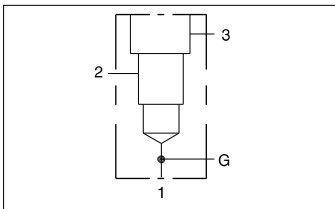

90 degree body with high capacity port 3 and gage port.

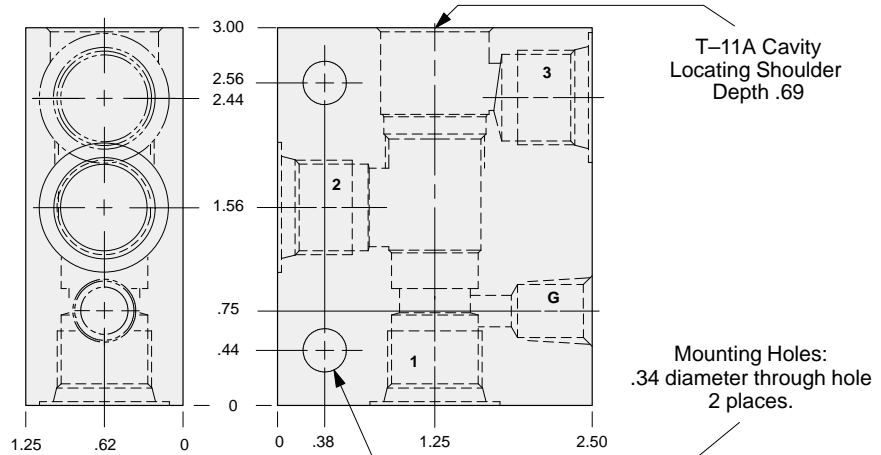

TYPICAL CARTRIDGES USED WITH THIS BODY

PPDB - ***	Page 3.10
FRCA - ***	Page 6.02
DPBA - ***	Page 8.06
DPBB - ***	Page 8.07
DPBC - ***	Page 8.08
DPBD - ***	Page 8.09

Instructions for ordering complete cartridge and body assemblies. Page v

Pressure ratings, material specifications. Page 11.02

Ports 1 & 2	Port 3	Gage Port	ALUMINUM		DUCTILE IRON	
			Part Number	List Price	Part Number	List Price
.375 NPTF	.375 NPTF	.25 NPTF	ELB		ELB/S	
.50 NPTF	.375 NPTF	.25 NPTF	ELC		ELC/S	
SAE-6	SAE-6	.25 NPTF	ELI		ELI/S	
SAE-8	SAE-8	.25 NPTF	ELJ		ELJ/S	
SAE-10	SAE-8	.25 NPTF	ELK		ELK/S	
.50 BSPP	.375 BSPP	.25 BSPP	ELV		ELV/S	

S1
T11A



LINE MOUNT BODIES

- Aluminum rated to 3000 psi.
- Ductile Iron rated to 5000 psi.

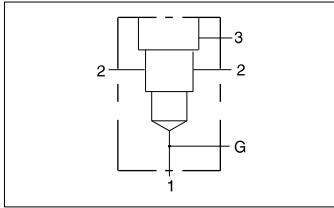

TYPICAL CARTRIDGES USED WITH THIS BODY

PBDB - *** Page 3.06

Instructions for ordering complete cartridge and body assemblies. Page v

Pressure ratings, material specifications. Page 11.02

Through port body with gage port for reducing applications.

Mounting Holes:
(opposite side)
Inch: .375-16 UNC-2B x .62 deep.
Metric: M10 x 1.50-6H x .62 deep.

T-11A Cavity
Locating Shoulder
Depth .81

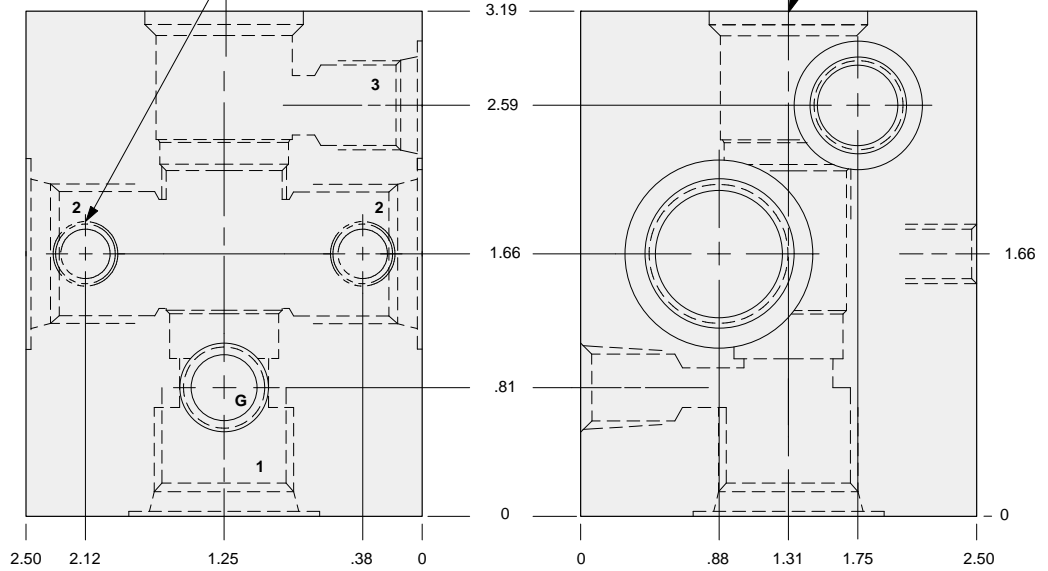

Ports 1 & 2	Port 3	Gage Port	ALUMINUM		DUCTILE IRON	
			Part Number	List Price	Part Number	List Price
.25 NPTF	.25 NPTF	.25 NPTF	WRM		WRM/S	
.375 NPTF	.25 NPTF	.25 NPTF	WRN		WRN/S	
.50 NPTF	.25 NPTF	.25 NPTF	WRO		WRO/S	
SAE-6	SAE-6	.25 NPTF	WRP		WRP/S	
SAE-8	SAE-6	.25 NPTF	WRQ		WRQ/S	
SAE-10	SAE-6	.25 NPTF	WRR		WRR/S	
.25 BSPP	.25 BSPP	.25 BSPP	WRS		WRS/S	
.375 BSPP	.25 BSPP	.25 BSPP	WRT		WRT/S	
.50 BSPP	.25 BSPP	.25 BSPP	WRU		WRU/S	
.375 NPTF	.375 NPTF	.25 NPTF	WRX		WRX/S	
.50 NPTF	.375 NPTF	.25 NPTF	WRY		WRY/S	
SAE-8	SAE-8	.25 NPTF	WRZ		WRZ/S	
SAE-10	SAE-8	.25 NPTF	WSB		WSB/S	
.375 BSPP	.375 BSPP	.25 BSPP	WSC		WSC/S	
.50 BSPP	.375 BSPP	.25 BSPP	WSD		WSD/S	

S1
T11A



LINE MOUNT BODIES



- Aluminum rated to 3000 psi.
- Ductile Iron rated to 5000 psi.

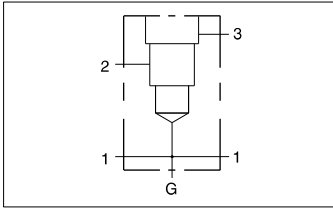

Through port body with gage port.

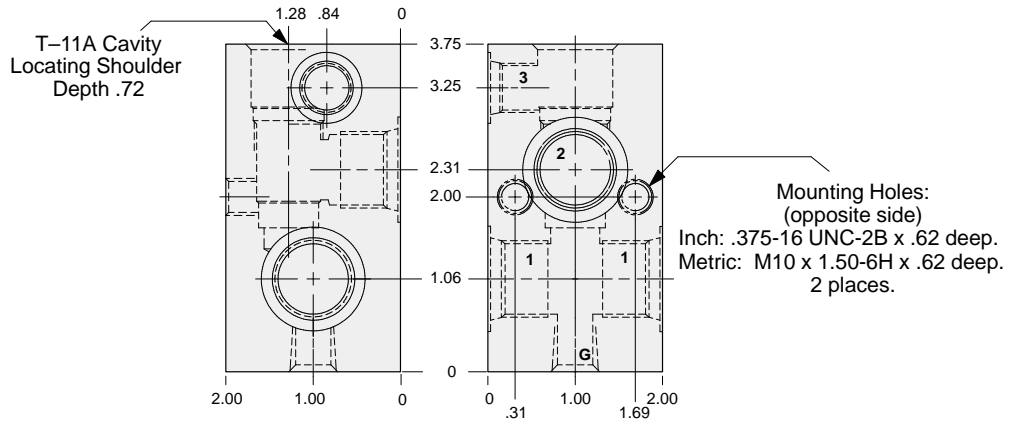

TYPICAL CARTRIDGES USED WITH THIS BODY

RBAD - ***	Page 1.17
RVCA - ***	Page 1.18
RSDC - ***	Page 2.06
SQDB - ***	Page 2.08
SCCA - ***	Page 2.12
PBDB - ***	Page 3.06
LODC - ***	Page 9.08

Instructions for ordering complete cartridge and body assemblies. Page v

Pressure ratings, material specifications. Page 11.02

Mounting Hole Dimensions	Ports 1 & 2	Port 3	Gage Port	ALUMINUM		DUCTILE IRON	
				Part Number	List Price	Part Number	List Price
Inch	.25 NPTF	.25 NPTF	.25 NPTF	EHA		EHA/S	
Inch	.375 NPTF	.25 NPTF	.25 NPTF	EHB		EHB/S	
Inch	.50 NPTF	.25 NPTF	.25 NPTF	EHC		EHC/S	
Inch	SAE-6	SAE-6	.25 NPTF	EHI		EHI/S	
Inch	SAE-8	SAE-6	.25 NPTF	EHJ		EHJ/S	
Inch	SAE-10	SAE-6	.25 NPTF	EHK		EHK/S	
Metric	.25 BSPP	.25 BSPP	.25 BSPP	EHT		EHT/S	
Metric	.375 BSPP	.25 BSPP	.25 BSPP	EHU		EHU/S	
Metric	.50 BSPP	.25 BSPP	.25 BSPP	EHV		EHV/S	

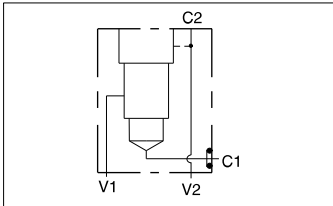

Gasket mount body for load control applications.

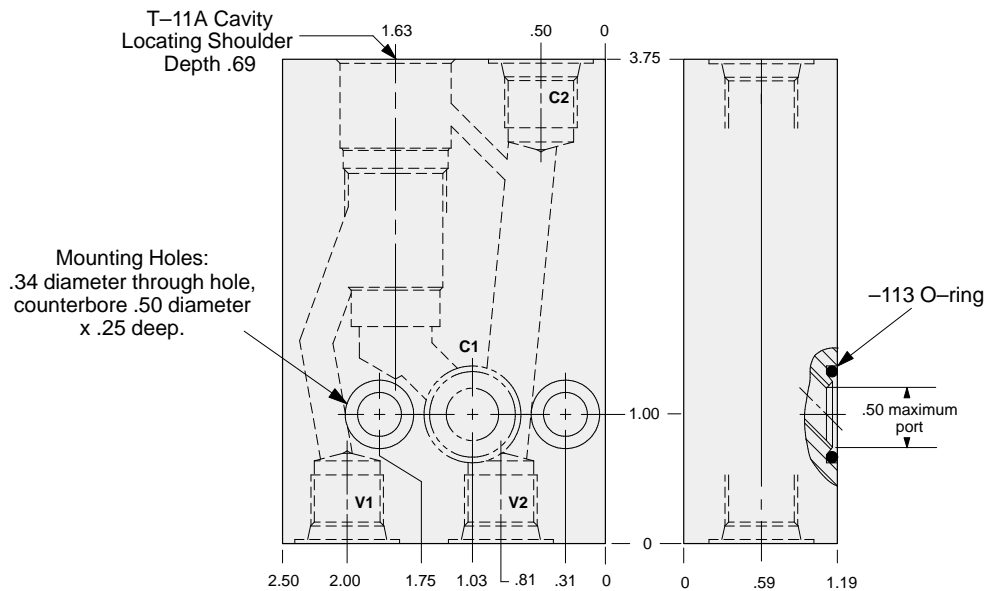

TYPICAL CARTRIDGES USED WITH THIS BODY

CBCA - ***	Page 4.10
CBCG - ***	Page 4.12
CBCH - ***	Page 4.14
CKCB - ***	Page 4.16

Cartridge seal type determines O-ring type.

Instructions for ordering complete cartridge and body assemblies. Page v

Pressure ratings, material specifications. Page 11.02

Ports C2, V1, V2	ALUMINUM		DUCTILE IRON	
	Part Number	List Price	Part Number	List Price
.375 NPTF	ZTN		ZTN/S	
SAE-6	ZTC		ZTC/S	
.375 BSPP	ZTD		ZTD/S	

S1
T11A



LINE MOUNT BODIES



- Aluminum rated to 3000 psi.
- Ductile Iron rated to 5000 psi.

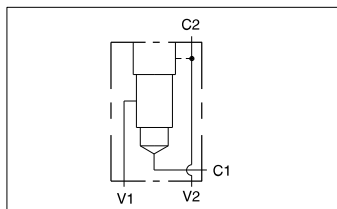

TYPICAL CARTRIDGES USED WITH THIS BODY

- CBCA - *** Page 4.10
- CBCG - *** Page 4.12
- CBCH - *** Page 4.14
- CKCB - *** Page 4.16

Instructions for ordering complete cartridge and body assemblies. Page v

Pressure ratings, material specifications. Page 11.02

Nipple mount body for load control applications.

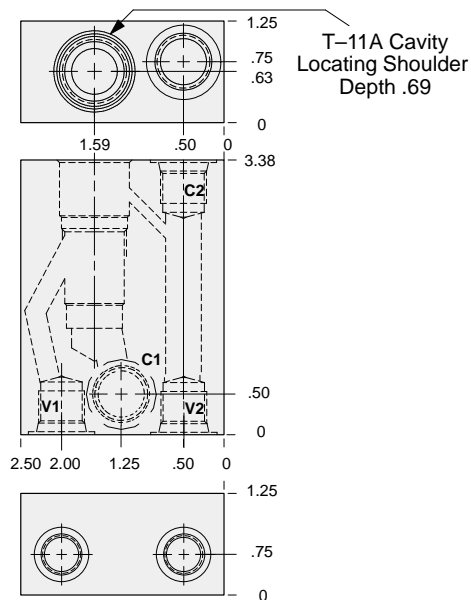

Port C1	Ports C2, & V1, V2	ALUMINUM		DUCTILE IRON	
		Part Number	List Price	Part Number	List Price
SAE-6	SAE-6	ZRK		ZRK/S	
.375 NPTF	SAE-6	ZTS		ZTS/S	
.375 NPTF	.375 NPTF	ZTZ		ZTZ/S	

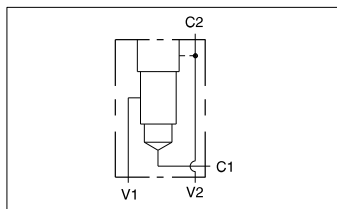

TYPICAL CARTRIDGES USED WITH THIS BODY

- CBCA - *** Page 4.10
- CBCG - *** Page 4.12
- CBCH - *** Page 4.14
- CKCB - *** Page 4.16

Instructions for ordering complete cartridge and body assemblies. Page v

Pressure ratings, material specifications. Page 11.02

Nipple mount body for load control applications.

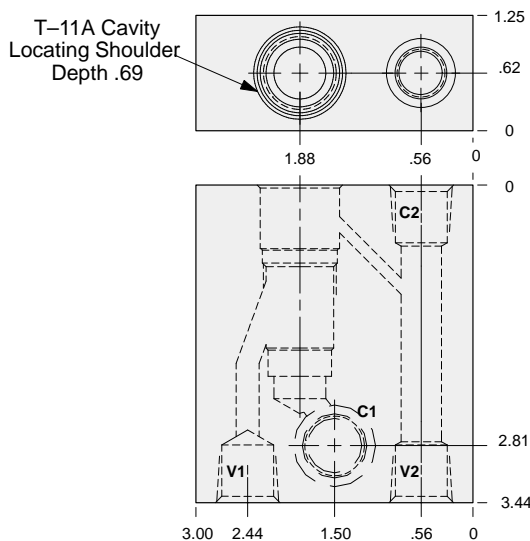

Ports C1	Ports C2, V1, V2	ALUMINUM		DUCTILE IRON	
		Part Number	List Price	Part Number	List Price
SAE-8	SAE-8	WPE		WPE/S	
SAE-8	SAE-6	ZRL		ZRL/S	
.50 NPTF	.375 NPTF	ZTY		ZTY/S	

S1
T11A



LINE MOUNT BODIES



- Aluminum rated to 3000 psi.
- Ductile Iron rated to 5000 psi.

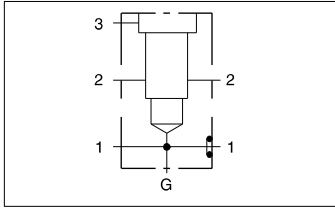

Flange mount through port .75" SAE Code 61 body with threaded outlet and gage port.

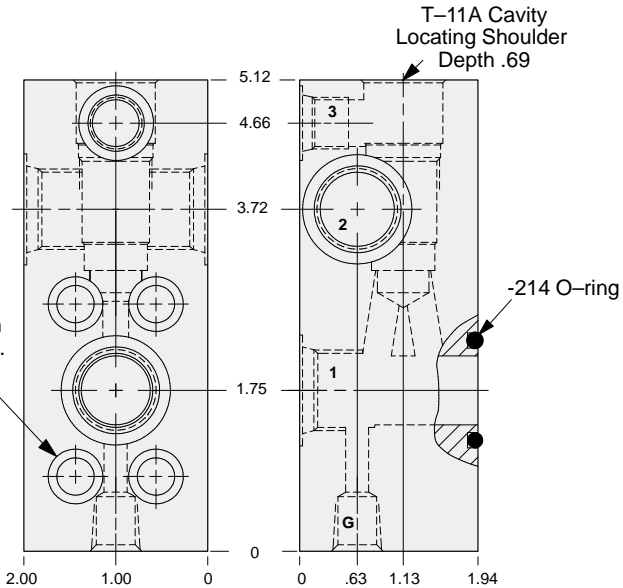

TYPICAL CARTRIDGES USED WITH THIS BODY

- RVCA - *** Page 1.18
- RSDC - *** Page 2.06
- SQDB - *** Page 2.08
- SCCA - *** Page 2.12
- LODC - *** Page 9.08
- LKDC - *** Page 9.10
- LPDC - *** Page 9.12
- LRDC - *** Page 9.14

Cartridge seal type determines O-ring type.

Instructions for ordering complete cartridge and body assemblies. Page v

Pressure ratings, material specifications. Page 11.02

SAE Specifications Page 11.03

Mounting Hole Dimensions	Threaded Ports 1 & 2	Port 3	Gage Port	ALUMINUM		DUCTILE IRON	
				Part Number	List Price	Part Number	List Price
Inch	SAE-10	SAE-6	.25 NPTF	WYY		WYY/S	
Inch	.50 NPTF	.25 NPTF	.25 NPTF	WYZ		WYZ/S	
Metric	.50 BSPP	.25 BSPP	.25 BSPP	WYX/M		WYX/T	

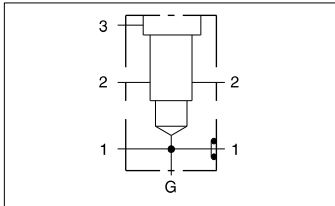

Flange mount through port .75" SAE Code 62 body with threaded outlet and gage port.

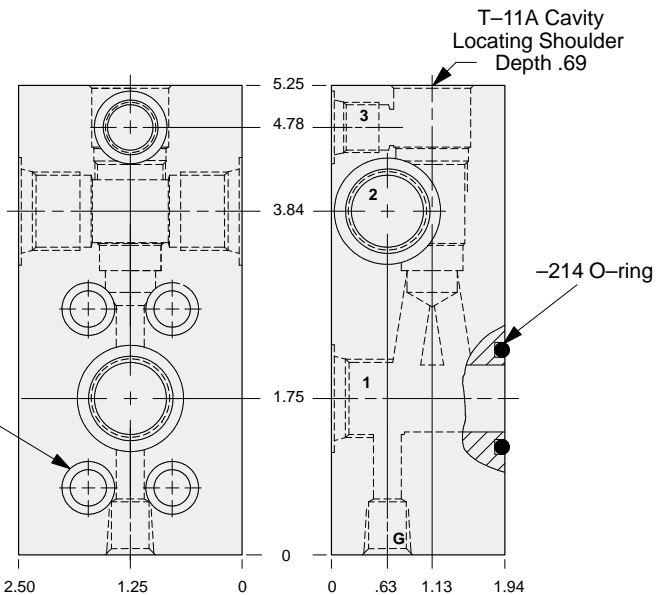

TYPICAL CARTRIDGES USED WITH THIS BODY

- RVCA - *** Page 1.18
- RSDC - *** Page 2.06
- SQDB - *** Page 2.08
- SCCA - *** Page 2.12
- LODC - *** Page 9.08
- LKDC - *** Page 9.10
- LPDC - *** Page 9.12
- LRDC - *** Page 9.14

Cartridge seal type determines O-ring type.

Instructions for ordering complete cartridge and body assemblies. Page v

Pressure ratings, material specifications. Page 11.02

SAE Specifications Page 11.03

Mounting Hole Dimensions	Threaded Ports 1 & 2	Port 3	Gage Port	ALUMINUM		DUCTILE IRON	
				Part Number	List Price	Part Number	List Price
Inch	.50 NPTF	.25 NPTF	.25 NPTF	WYK		WYK/S	
Inch	SAE-10	SAE-6	.25 NPTF	WYJ		WYJ/S	
Metric	.50 BSPP	.25 BSPP	.25 BSPP	WYI/M		WYI/T	

S1
T11A



LINE MOUNT BODIES



- Aluminum rated to 3000 psi.
- Ductile Iron rated to 5000 psi.

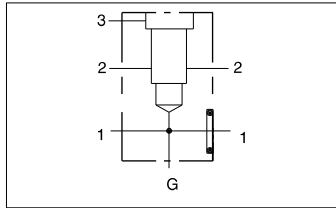

TYPICAL CARTRIDGES USED WITH THIS BODY

RVCA - ***	Page 1.18
RSDC - ***	Page 2.06
SQDB - ***	Page 2.08
SCCA - ***	Page 2.12
LODC - ***	Page 9.08
LKDC - ***	Page 9.10
LPDC - ***	Page 9.12
LRDC - ***	Page 9.14

Cartridge seal type determines O-ring type.

Instructions for ordering complete cartridge and body assemblies. Page v

Pressure ratings, material specifications. Page 11.02

SAE Specifications Page 11.03

Sandwich mount through port .75" SAE Code 61 body with gage port.

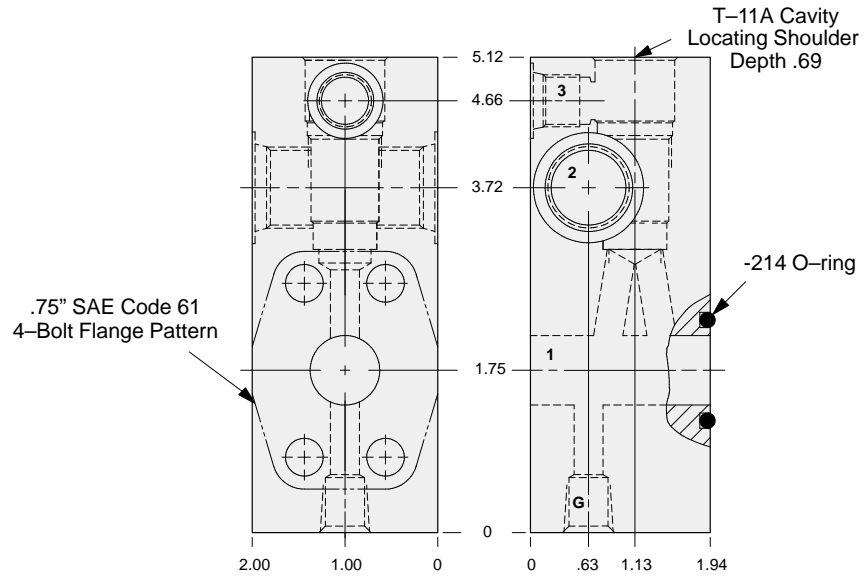

Mounting Hole Dimensions	Port 2	Port 3	Gage Port	ALUMINUM		DUCTILE IRON	
				Part Number	List Price	Part Number	List Price
Inch	SAE-10	SAE-6	.25 NPTF	ZML		ZML/S	
Metric	.50 BSPP	.25 BSPP	.25 BSPP	ZMK/M		ZMK/T	

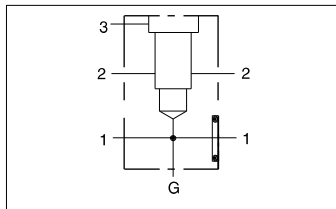

TYPICAL CARTRIDGES USED WITH THIS BODY

RVCA - ***	Page 1.18
RSDC - ***	Page 2.06
SQDB - ***	Page 2.08
SCCA - ***	Page 2.12
LODC - ***	Page 9.08
LKDC - ***	Page 9.10
LPDC - ***	Page 9.12
LRDC - ***	Page 9.14

Cartridge seal type determines O-ring type.

Instructions for ordering complete cartridge and body assemblies. Page v

Pressure ratings, material specifications. Page 11.02

SAE Specifications Page 11.03

Sandwich mount through port .75" SAE Code 62 body with gage port.

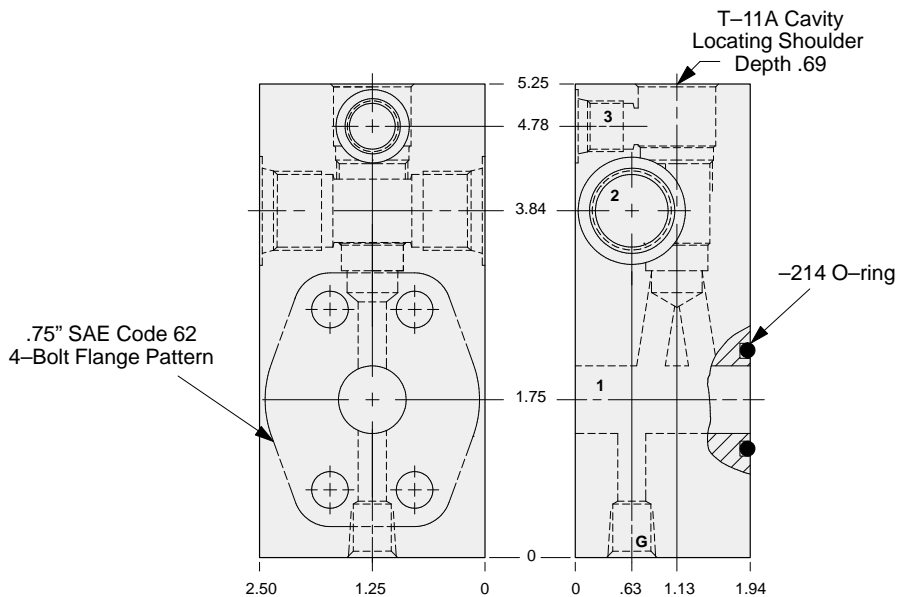

Mounting Hole Dimensions	Port 2	Port 3	Gage Port	ALUMINUM		DUCTILE IRON	
				Part Number	List Price	Part Number	List Price
Inch	.50 NPTF	.25 NPTF	.25 NPTF	WYN		WYN/S	
Inch	SAE-10	SAE-6	.25 NPTF	WYM		WYM/S	
Metric	.50 BSPP	.25 BSPP	.25 BSPP	WYL/M		WYL/T	

S1
T11A



LINE MOUNT BODIES



- Aluminum rated to 3000 psi.
- Ductile Iron rated to 5000 psi.

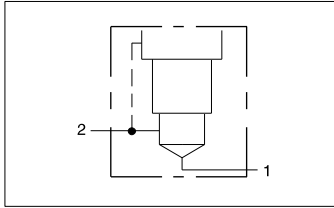

Inline body with port 3 connected to port 2.

TYPICAL CARTRIDGES USED WITH THIS BODY

CBCA - *** Page 4.10
 CBCG - *** Page 4.12
 CBCH - *** Page 4.14

Instructions for ordering complete cartridge and body assemblies. Page v

Pressure ratings, material specifications. Page 11.02

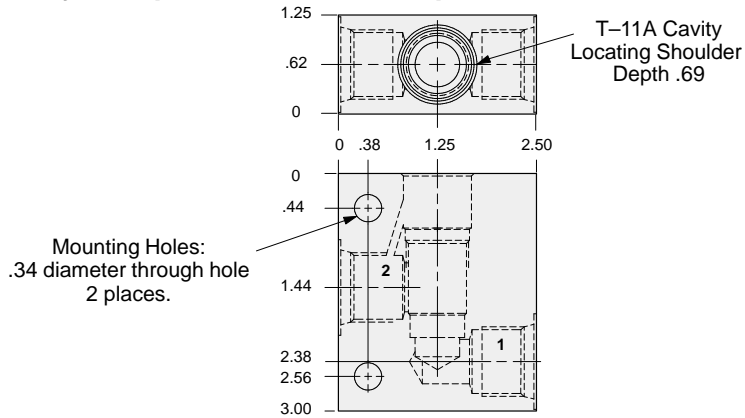

Ports 1 & 2	ALUMINUM		DUCTILE IRON	
	Part Number	List Price	Part Number	List Price
.25 NPTF	EDA		EDA/S	
.375 NPTF	EDB		EDB/S	
.50 NPTF	EDC		EDC/S	
SAE-6	EDI		EDI/S	
SAE-8	EDJ		EDJ/S	
SAE-10	EDK		EDK/S	
.25 BSPP	EDT		EDT/S	
.375 BSPP	EDU		EDU/S	
.50 BSPP	EDV		EDV/S	

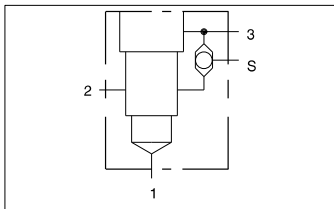

90 degree body with integral shuttle.

TYPICAL CARTRIDGES USED WITH THIS BODY

CBCA - *** Page 4.10
 CBCG - *** Page 4.12
 CBCH - *** Page 4.14
 CKCB - *** Page 4.16

Instructions for ordering complete cartridge and body assemblies. Page v

Pressure ratings, material specifications. Page 11.02

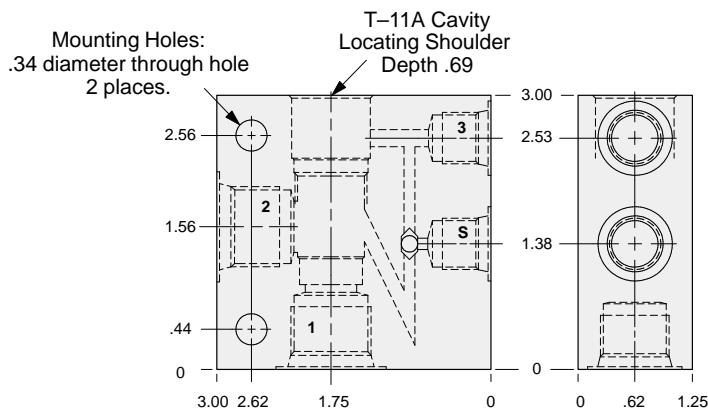

Ports 1 & 2	Port 3 & S	ALUMINUM		DUCTILE IRON	
		Part Number	List Price	Part Number	List Price
.25 NPTF	.25 NPTF	EGA		EGA/S	
.375 NPTF	.25 NPTF	EGB		EGB/S	
.50 NPTF	.25 NPTF	EGC		EGC/S	
SAE-6	SAE-6	EGI		EGI/S	
SAE-8	SAE-6	EGJ		EGJ/S	
SAE-10	SAE-6	EGK		EGK/S	
.25 BSPP	.25 BSPP	EGT		EGT/S	
.375 BSPP	.25 BSPP	EGU		EGU/S	
.50 BSPP	.25 BSPP	EGV		EGV/S	

S1
T11A



LINE MOUNT BODIES



- Aluminum rated to 3000 psi.
- Ductile Iron rated to 5000 psi.

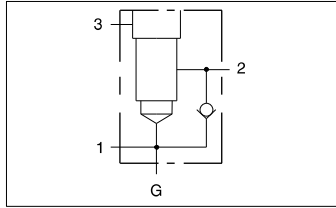

Body with reverse free flow check and gage port for reducing applications.

T-11A Cavity
Locating Shoulder
Depth .81

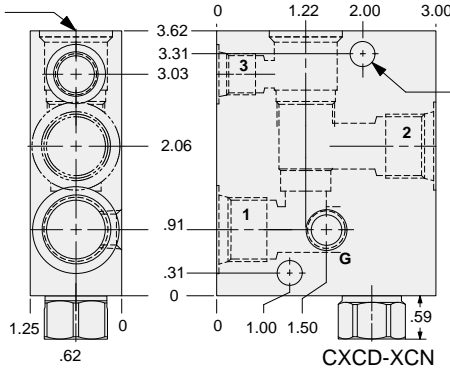

Mounting Holes:
.34 diameter through hole.
2 places.

TYPICAL CARTRIDGES USED WITH THIS BODY

PBDB - *** Page 3.06

Cartridge seal type determines
check valve seal type.

Instructions for ordering
complete cartridge and body
assemblies. Page v

Pressure ratings, material
specifications. Page 11.02

Ports 1 & 2	Port 3	Gage Port	ALUMINUM		DUCTILE IRON	
			Part Number	List Price	Part Number	List Price
.25 NPTF	.25 NPTF	.25 NPTF	E2A		E2A/S	
.375 NPTF	.25 NPTF	.25 NPTF	E2B		E2B/S	
.50 NPTF	.25 NPTF	.25 NPTF	E2C		E2C/S	
SAE-6	SAE-6	.25 NPTF	E2I		E2I/S	
SAE-8	SAE-6	.25 NPTF	E2J		E2J/S	
SAE-10	SAE-6	.25 NPTF	E2K		E2K/S	
.25 BSPP	.25 BSPP	.25 BSPP	E2T		E2T/S	
.375 BSPP	.25 BSPP	.25 BSPP	E2U		E2U/S	
.50 BSPP	.25 BSPP	.25 BSPP	E2V		E2V/S	

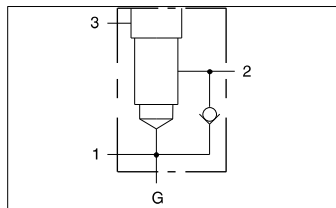

Body with high capacity port 3, reverse free flow check and
gage port for reducing/relieving applications.

T-11A Cavity
Locating Shoulder
Depth .81

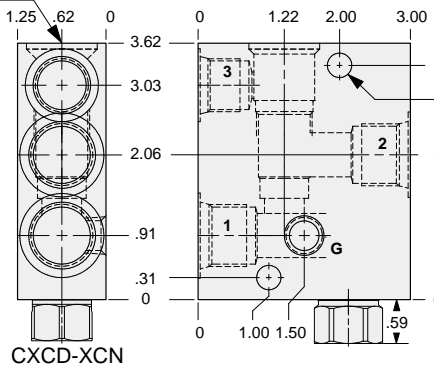

Mounting Holes:
.34 diameter through hole.
2 places.

TYPICAL CARTRIDGES USED WITH THIS BODY

PPDB - *** Page 3.10

Cartridge seal type determines
check valve seal type.

Instructions for ordering
complete cartridge and body
assemblies. Page v

Pressure ratings, material
specifications. Page 11.02

Ports 1 & 2	Port 3	Gage Port	ALUMINUM		DUCTILE IRON	
			Part Number	List Price	Part Number	List Price
.25 NPTF	.25 NPTF	.25 NPTF	E4A		E4A/S	
.375 NPTF	.375 NPTF	.25 NPTF	E4B		E4B/S	
.50 NPTF	.375 NPTF	.25 NPTF	E4C		E4C/S	
SAE-6	SAE-6	.25 NPTF	E4I		E4I/S	
SAE-8	SAE-8	.25 NPTF	E4J		E4J/S	
SAE-10	SAE-8	.25 NPTF	E4K		E4K/S	
.25 BSPP	.25 BSPP	.25 BSPP	E4T		E4T/S	
.375 BSPP	.375 BSPP	.25 BSPP	E4U		E4U/S	
.50 BSPP	.375 BSPP	.25 BSPP	E4V		E4V/S	

S1
T11A



LINE MOUNT BODIES



- Aluminum rated to 3000 psi.
- Ductile Iron rated to 5000 psi.

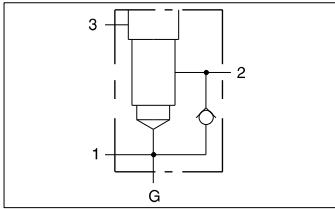

Body with reverse free flow check and gage port.

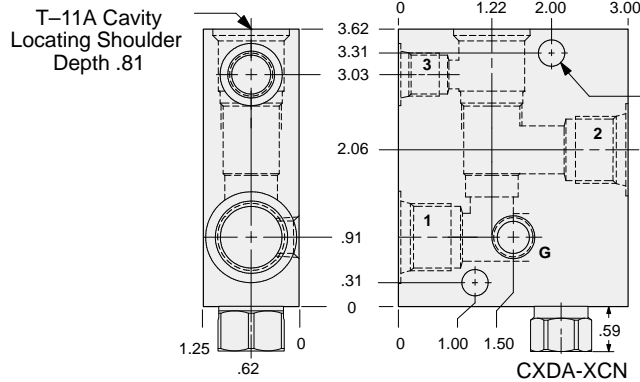

Mounting Holes:
.34 diameter through hole.
2 places.

TYPICAL CARTRIDGES USED WITH THIS BODY

RVCA - *** Page 1.18
RSDC - *** Page 2.06
SQDB - *** Page 2.08

Cartridge seal type determines check valve seal type.

Instructions for ordering complete cartridge and body assemblies. Page v

Pressure ratings, material specifications. Page 11.02

Ports 1 & 2	Port 3	Gage Port	ALUMINUM		DUCTILE IRON	
			Part Number	List Price	Part Number	List Price
.25 NPTF	.25 NPTF	.25 NPTF	E6A		E6A/S	
.375 NPTF	.25 NPTF	.25 NPTF	E6B		E6B/S	
.50 NPTF	.25 NPTF	.25 NPTF	E6C		E6C/S	
SAE-6	SAE-6	.25 NPTF	E6I		E6I/S	
SAE-8	SAE-6	.25 NPTF	E6J		E6J/S	
SAE-10	SAE-6	.25 NPTF	E6K		E6K/S	
.25 BSPP	.25 BSPP	.25 BSPP	E6T		E6T/S	
.375 BSPP	.25 BSPP	.25 BSPP	E6U		E6U/S	
.50 BSPP	.25 BSPP	.25 BSPP	E6V		E6V/S	

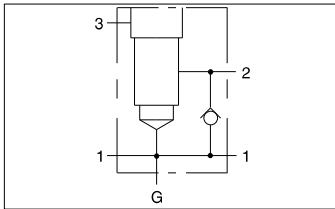

Through port body with reverse free flow check and gage port.

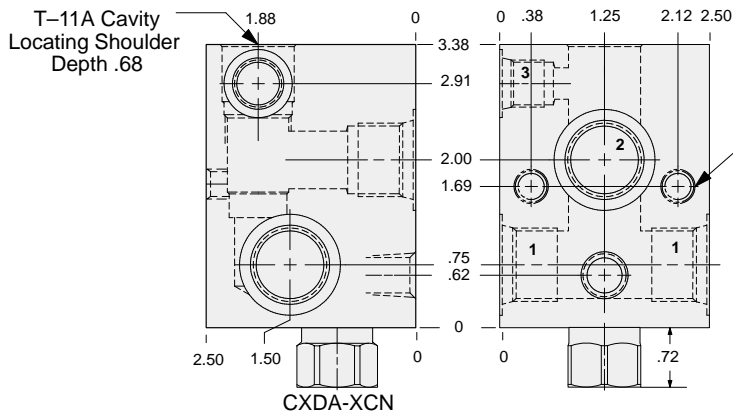

Mounting Holes:
(opposite side)
Inch: .375-16 UNC-2B
x .62 deep.
Metric: M10 x 1.50-6H
x .62 deep.
2 places.

TYPICAL CARTRIDGES USED WITH THIS BODY

RSDC - *** Page 2.06
SQDB - *** Page 2.08

Cartridge seal type determines check valve seal type.

Instructions for ordering complete cartridge and body assemblies. Page v

Pressure ratings, material specifications. Page 11.02

Mounting Hole Dimensions	Ports 1 & 2	Port 3	Gage Port	ALUMINUM		DUCTILE IRON	
				Part Number	List Price	Part Number	List Price
Inch	.25 NPTF	.25 NPTF	.25 NPTF	E7A		E7A/S	
Inch	.375 NPTF	.25 NPTF	.25 NPTF	E7B		E7B/S	
Inch	.50 NPTF	.25 NPTF	.25 NPTF	E7C		E7C/S	
Inch	SAE-6	SAE-6	.25 NPTF	E7I		E7I/S	
Inch	SAE-8	SAE-6	.25 NPTF	E7J		E7J/S	
Inch	SAE-10	SAE-6	.25 NPTF	E7K		E7K/S	
Metric	.25 BSPP	.25 BSPP	.25 BSPP	E7T		E7T/S	
Metric	.375 BSPP	.25 BSPP	.25 BSPP	E7U		E7U/S	
Metric	.50 BSPP	.25 BSPP	.25 BSPP	E7V		E7V/S	

S1
T11A



LINE MOUNT BODIES



- Aluminum rated to 3000 psi.
- Ductile Iron rated to 5000 psi.

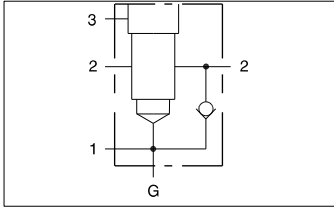

TYPICAL CARTRIDGES USED WITH THIS BODY

PBDB - *** Page 3.06

Cartridge seal type determines check valve seal type.

Instructions for ordering complete cartridge and body assemblies. Page v

Pressure ratings, material specifications. Page 11.02

Through port body with reverse free flow check and gage port for reducing applications.

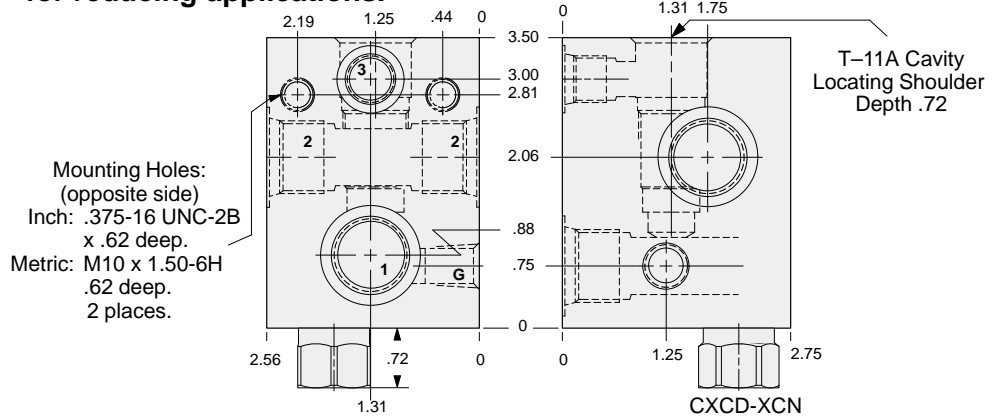

Mounting Hole Dimensions	Ports 1 & 2	Port 3	Gage Port	ALUMINUM		DUCTILE IRON	
				Part Number	List Price	Part Number	List Price
Inch .25 NPTF	.25 NPTF	.25 NPTF	.25 NPTF	E3A		E3A/S	
Inch .375 NPTF	.25 NPTF	.25 NPTF	.25 NPTF	E3B		E3B/S	
Inch .50 NPTF	.25 NPTF	.25 NPTF	.25 NPTF	E3C		E3C/S	
Inch SAE-6	SAE-6	.25 NPTF	.25 NPTF	E3I		E3I/S	
Inch SAE-8	SAE-6	.25 NPTF	.25 NPTF	E3J		E3J/S	
Inch SAE-10	SAE-6	.25 NPTF	.25 NPTF	E3K		E3K/S	
Metric .25 BSPP	.25 BSPP	.25 BSPP	.25 BSPP	E3T		E3T/S	
Metric .375 BSPP	.25 BSPP	.25 BSPP	.25 BSPP	E3U		E3U/S	
Metric .50 BSPP	.25 BSPP	.25 BSPP	.25 BSPP	E3V		E3V/S	

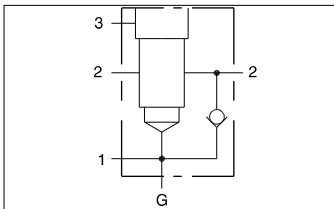

TYPICAL CARTRIDGES USED WITH THIS BODY

PPDB - *** Page 3.10

Cartridge seal type determines check valve seal type.

Instructions for ordering complete cartridge and body assemblies. Page v

Pressure ratings, material specifications. Page 11.02

Through port body with high capacity port 3, reverse free flow check and gage port for reducing/relieving applications.

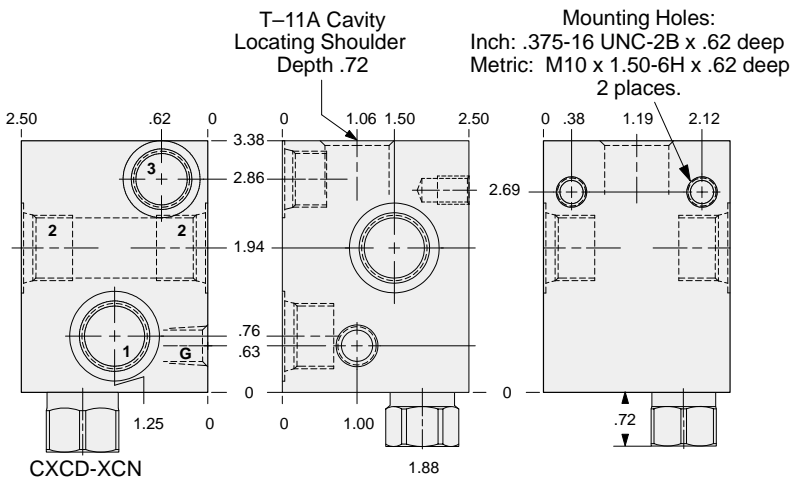

Mounting Hole Dimensions	Ports 1 & 2	Port 3	Gage Port	ALUMINUM		DUCTILE IRON	
				Part Number	List Price	Part Number	List Price
Inch .375 NPTF	.375 NPTF	.375 NPTF	.25 NPTF	E5B		E5B/S	
Inch .50 NPTF	.375 NPTF	.375 NPTF	.25 NPTF	E5C		E5C/S	
Inch SAE-8	SAE-8	.25 NPTF	.25 NPTF	E5J		E5J/S	
Inch SAE-10	SAE-8	.25 NPTF	.25 NPTF	E5K		E5K/S	
Metric .375 BSPP	.375 BSPP	.25 BSPP	.25 BSPP	E5U		E5U/S	
Metric .50 BSPP	.375 BSPP	.25 BSPP	.25 BSPP	E5V		E5V/S	

S1
T11A



LINE MOUNT BODIES



- Aluminum rated to 3000 psi.
- Ductile Iron rated to 5000 psi.

Two cavity 90 degree cross-piloted body for load control applications.

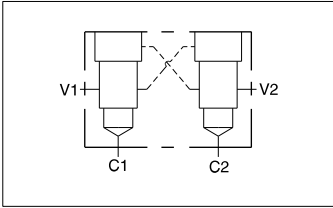

TYPICAL CARTRIDGES USED WITH THIS BODY

- CBCA - *** Page 4.10
 CBCG - *** Page 4.12
 CBCH - *** Page 4.14
 CKCB - *** Page 4.16

Instructions for ordering complete cartridge and body assemblies. Page v

Pressure ratings, material specifications. Page 11.02

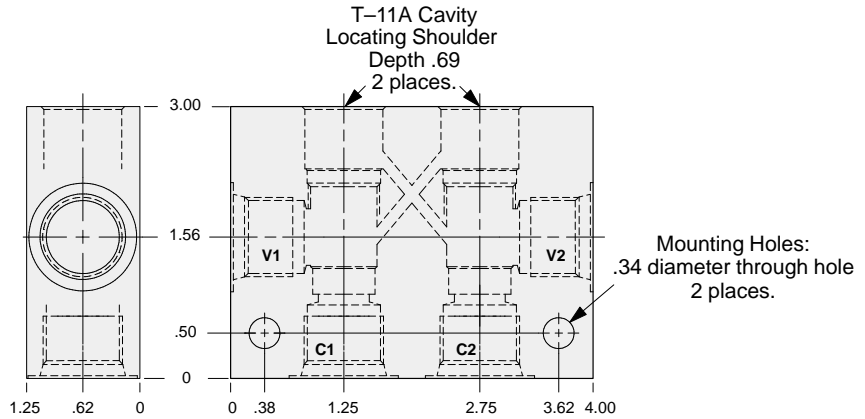

Ports C1, C2, & V1, V2	ALUMINUM		DUCTILE IRON	
	Part Number	List Price	Part Number	List Price
.25 NPTF	YEA		YEA/S	
.375 NPTF	YEB		YEB/S	
.50 NPTF	YEC		YEC/S	
SAE-6	YEI		YEI/S	
SAE-8	YEJ		YEJ/S	
SAE-10	YEK		YEK/S	
.25 BSPP	YET		YET/S	
.375 BSPP	YEU		YEU/S	
.50 BSPP	YEV		YEV/S	

Two cavity 90 degree cross-piloted body with shuttle for load control applications.

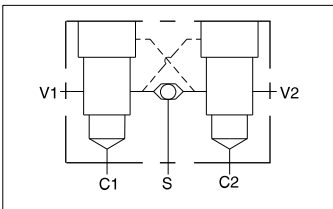

TYPICAL CARTRIDGES USED WITH THIS BODY

- CBCA - *** Page 4.10
 CBCG - *** Page 4.12
 CBCH - *** Page 4.14
 CKCB - *** Page 4.16

Instructions for ordering complete cartridge and body assemblies. Page v

Pressure ratings, material specifications. Page 11.02

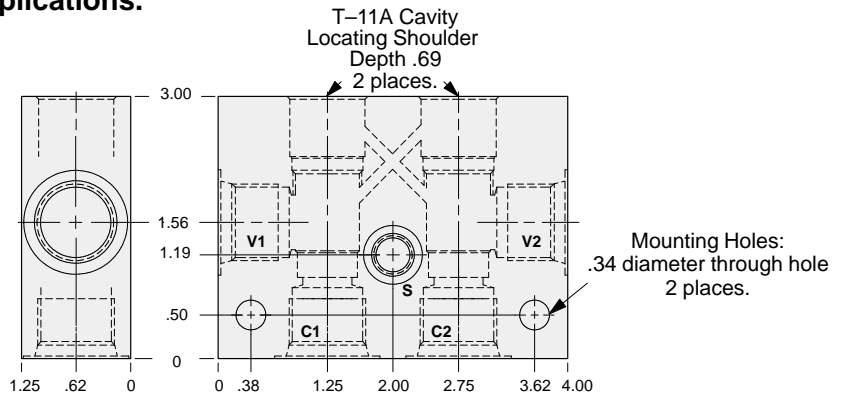

Ports C1, C2, & V1, V2	Port S	ALUMINUM		DUCTILE IRON	
		Part Number	List Price	Part Number	List Price
.25 NPTF	.25 NPTF	YGA		YGA/S	
.375 NPTF	.25 NPTF	YGB		YGB/S	
.50 NPTF	.25 NPTF	YGC		YGC/S	
SAE-6	SAE-4	YGI		YGI/S	
SAE-8	SAE-4	YGJ		YGJ/S	
SAE-10	SAE-4	YGK		YGK/S	
.25 BSPP	.25 BSPP	YGT		YGT/S	
.375 BSPP	.25 BSPP	YGU		YGU/S	
.50 BSPP	.25 BSPP	YGV		YGV/S	



LINE MOUNT BODIES



- Aluminum rated to 3000 psi.
- Ductile Iron rated to 5000 psi.

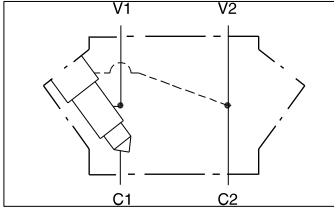

TYPICAL CARTRIDGES USED WITH THIS BODY

- CBCA - *** Page 4.10
- CBCG - *** Page 4.12
- CBCH - *** Page 4.14
- CKCB - *** Page 4.16

Instructions for ordering complete cartridge and body assemblies. Page v

Pressure ratings, material specifications. Page 11.02

Inline body for load control applications.

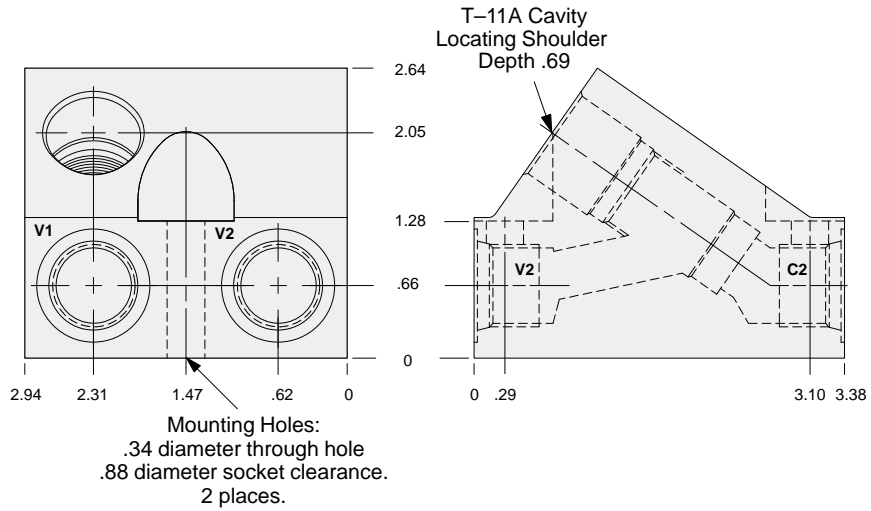

Ports C1, C2, & V1, V2	ALUMINUM		DUCTILE IRON	
	Part Number	List Price	Part Number	List Price
.25 NPTF	XVF		XVF/S	
.375 NPTF	XVG		XVG/S	
SAE-6	XVH		XVH/S	
SAE-8	XVI		XVI/S	
.25 BSPP	XVJ		XVJ/S	
.375 BSPP	XVK		XVK/S	

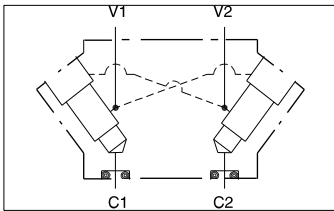

TYPICAL CARTRIDGES USED WITH THIS BODY

- CBCA - *** Page 4.10
- CBCG - *** Page 4.12
- CBCH - *** Page 4.14
- CKCB - *** Page 4.16

Cartridge seal type determines O-ring type.

Instructions for ordering complete cartridge and body assemblies. Page v

Pressure ratings, material specifications. Page 11.02

Two cavity inline gasket mount cross-piloted body for load control applications.

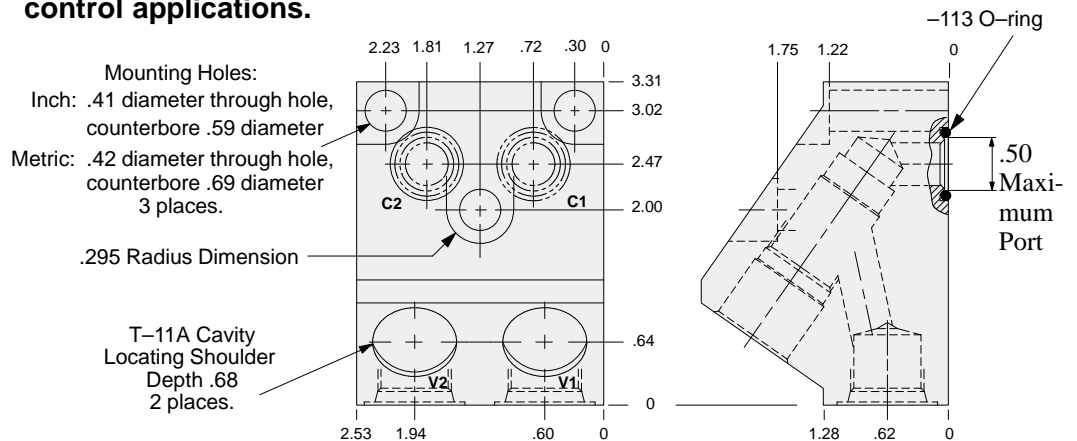

Mounting Hole Dimensions	Ports V1, V2	ALUMINUM		DUCTILE IRON	
		Part Number	List Price	Part Number	List Price
Inch	.25 NPTF	XVL		XVL/S	
Inch	.375 NPTF	XVM		XVM/S	
Inch	SAE-6	XVN		XVN/S	
Inch	SAE-8	XVO		XVO/S	
Metric	.25 BSPP	XVP		XVP/S	
Metric	.375 BSPP	XVQ		XVQ/S	

S1
T11A



LINE MOUNT BODIES



- Aluminum rated to 3000 psi.
- Ductile Iron rated to 5000 psi.

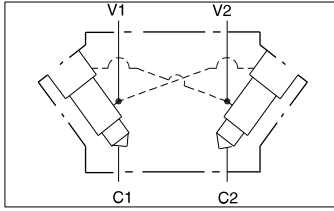

Two cavity inline cross-piloted body for load control applications.

TYPICAL CARTRIDGES USED WITH THIS BODY

CBCA - ***	Page 4.10
CBCG - ***	Page 4.12
CBCH - ***	Page 4.14
CKCB - ***	Page 4.16

Instructions for ordering complete cartridge and body assemblies. Page v

Pressure ratings, material specifications. Page 11.02

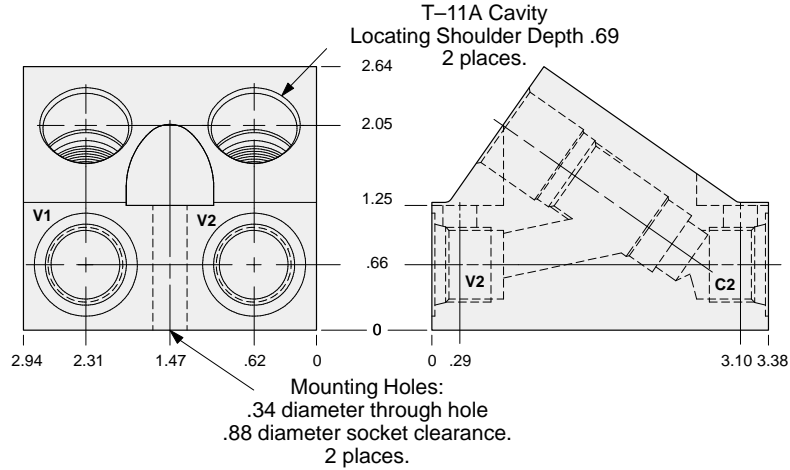

Ports C1, C2, & V1, V2	ALUMINUM		DUCTILE IRON	
	Part Number	List Price	Part Number	List Price
.25 NPTF	XEA		XEA/S	
.375 NPTF	XEB		XEB/S	
SAE-6	XEI		XEI/S	
SAE-8	XEJ		XEJ/S	
.25 BSPP	XET		XET/S	
.375 BSPP	XEU		XEU/S	
.50 BSPP	XEV		XEV/S	

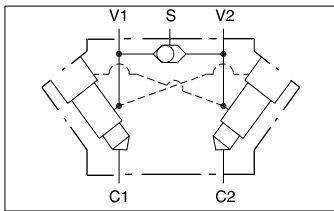

Two cavity inline cross-piloted body with shuttle for load control applications.

TYPICAL CARTRIDGES USED WITH THIS BODY

CBCA - ***	Page 4.10
CBCG - ***	Page 4.12
CBCH - ***	Page 4.14
CKCB - ***	Page 4.16

Instructions for ordering complete cartridge and body assemblies. Page v

Pressure ratings, material specifications. Page 11.02

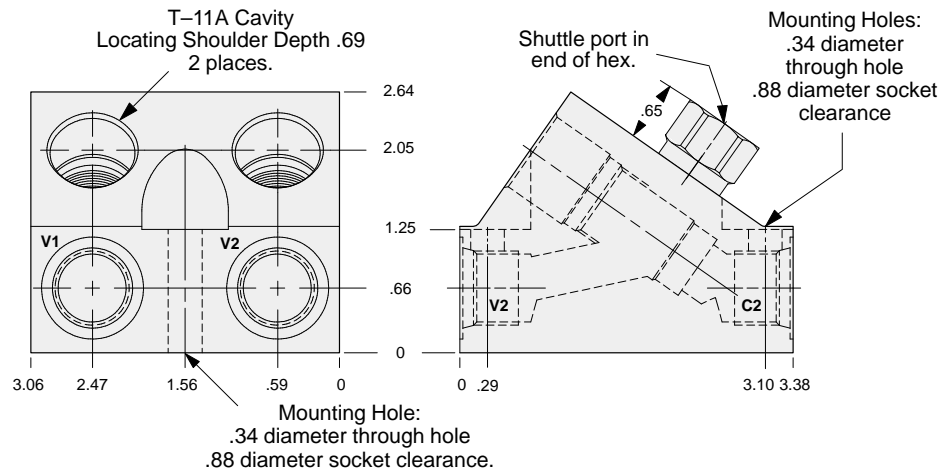

Ports C1, C2, & V1, V2	Shuttle Cartridge	Shuttle Port	ALUMINUM		DUCTILE IRON	
			Part Number	List Price	Part Number	List Price
.25 NPTF	CSAA - EXN	SAE-4	XGA		XGA/S	
.375 NPTF	CSAA - EXN	SAE-4	XGB		XGB/S	
SAE-6	CSAA - EXN	SAE-4	XGI		XGI/S	
SAE-8	CSAA - EXN	SAE-4	XGJ		XGJ/S	
.25 BSPP	CSAA - BXN	.25 BSPP	XGT		XGT/S	
.375 BSPP	CSAA - BXN	.25 BSPP	XGU		XGU/S	

S1
T11A



LINE MOUNT BODIES



- Aluminum rated to 3000 psi.
- Ductile Iron rated to 5000 psi.

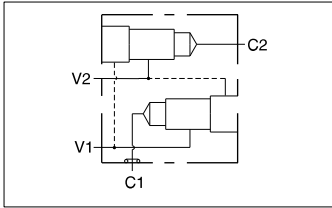

TYPICAL CARTRIDGES USED WITH THIS BODY

- CBCA - *** Page 4.10
- CBCG - *** Page 4.12
- CBCH - *** Page 4.14
- CKCB - *** Page 4.16

Cartridge seal type determines O-ring type.

Instructions for ordering complete cartridge and body assemblies. Page v

Pressure ratings, material specifications. Page 11.02

Two cavity gasket mount body for load control applications.

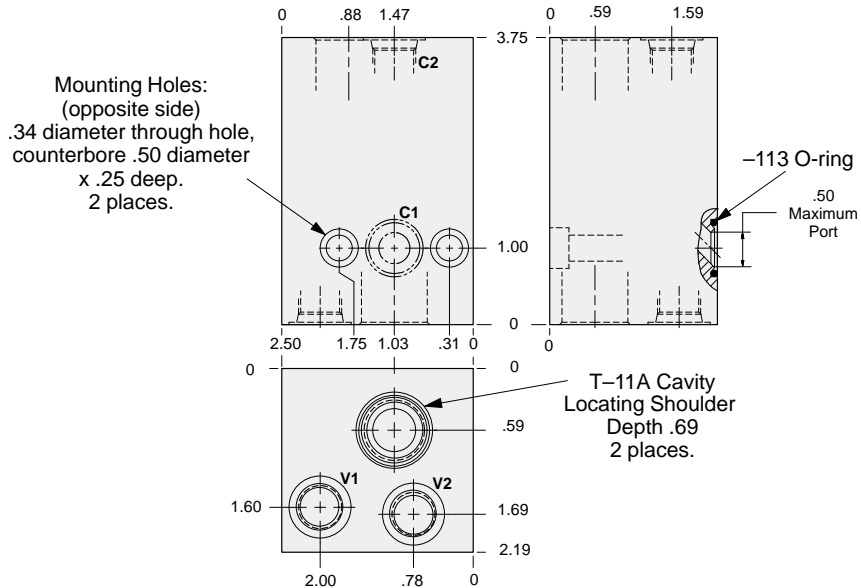

Ports C1, C2, & V1, V2	ALUMINUM		DUCTILE IRON	
	Part Number	List Price	Part Number	List Price
.375 NPTF	YVM		YVM/S	
SAE-6	YVY		YVY/S	
.375 BSPP	YVX		YVX/S	

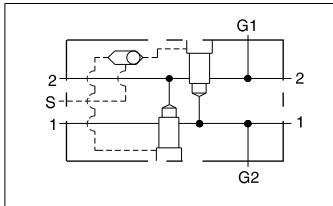

TYPICAL CARTRIDGES USED WITH THIS BODY

- RVCA - *** Page 1.18

Cartridge seal type determines shuttle valve seal type.

Instructions for ordering complete cartridge and body assemblies. Page v

Pressure ratings, material specifications. Page 11.02

Two cavity through port body with shuttle and gage ports.

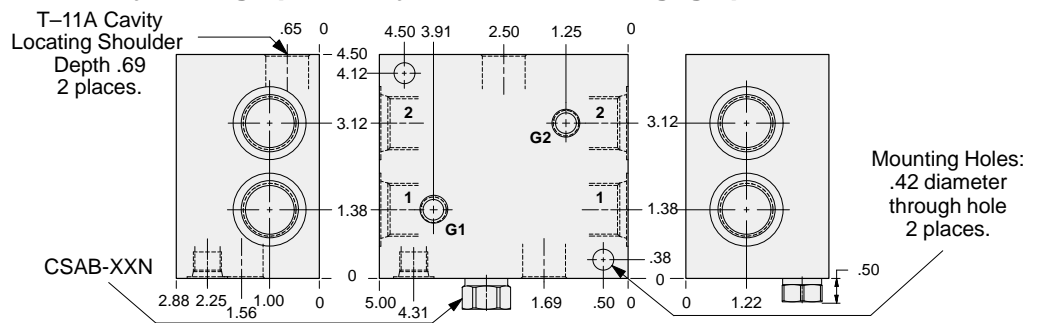

Ports 1 & 2	Port V	Ports G1 & G2	ALUMINUM		DUCTILE IRON	
			Part Number	List Price	Part Number	List Price
.25 NPTF	.25 NPTF	.25 NPTF	XOA		XOA/S	
.375 NPTF	.25 NPTF	.25 NPTF	XOB		XOB/S	
.50 NPTF	.25 NPTF	.25 NPTF	XOC		XOC/S	
.75 NPTF	.25 NPTF	.25 NPTF	XOD		XOD/S	
SAE-6	SAE-6	.25 NPTF	XOI		XOI/S	
SAE-8	SAE-6	.25 NPTF	XOJ		XOJ/S	
SAE-10	SAE-6	.25 NPTF	XOK		XOK/S	
SAE-12	SAE-6	.25 NPTF	XOL		XOL/S	
.25 BSPP	.25 BSPP	.25 BSPP	XOT		XOT/S	
.375 BSPP	.25 BSPP	.25 BSPP	XOU		XOU/S	
.50 BSPP	.25 BSPP	.25 BSPP	XOV		XOV/S	
.75 BSPP	.25 BSPP	.25 BSPP	XOW		XOW/S	

S1
T11A



LINE MOUNT BODIES



- Aluminum rated to 3000 psi.
- Ductile Iron rated to 5000 psi.

Two cavity dual load control body with checks.

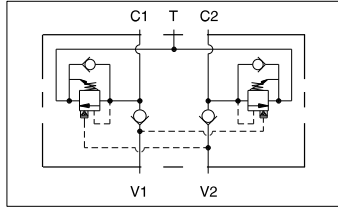
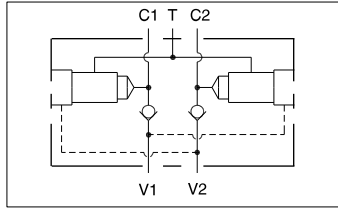

TYPICAL CARTRIDGES USED WITH THIS BODY

- CBCA - *** Page 4.10
CBCG - *** Page 4.12
CBCH - *** Page 4.14

Cartridge seal type determines check valve seal type.

Instructions for ordering complete cartridge and body assemblies. Page v

Pressure ratings, material specifications. Page 11.02

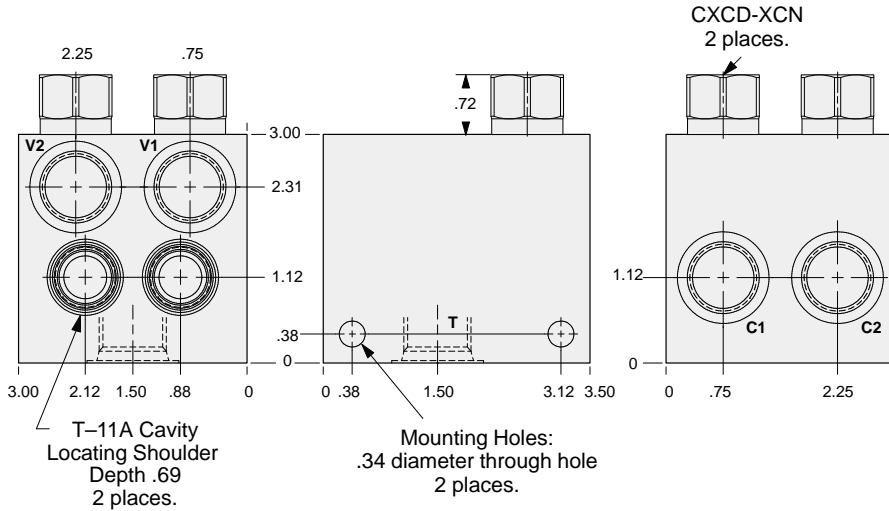

Ports C1, C2, & V1, V2	Port T	ALUMINUM		DUCTILE IRON	
		Part Number	List Price	Part Number	List Price
.375 NPTF	.50 NPTF	EMB		EMB/S	
.50 NPTF	.50 NPTF	EMC		EMC/S	
SAE-8	SAE-10	EMJ		EMJ/S	
SAE-10	SAE-10	EMK		EMK/S	
.375 BSPP	.50 BSPP	EMU		EMU/S	
.50 BSPP	.50 BSPP	EMV		EMV/S	

*Discharge oil returns to tank through port T.

Two cavity dual load control body with checks and shuttle.

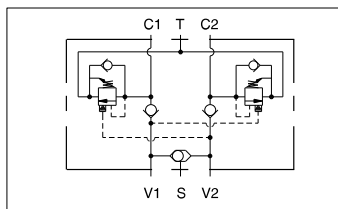
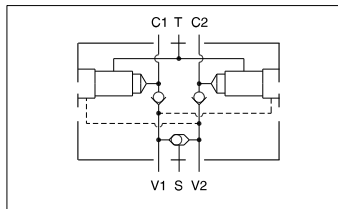

TYPICAL CARTRIDGES USED WITH THIS BODY

- CBCA - *** Page 4.10
CBCG - *** Page 4.12
CBCH - *** Page 4.14

Cartridge seal type determines check valve seal type.

Instructions for ordering complete cartridge and body assemblies. Page v

Pressure ratings, material specifications. Page 11.02

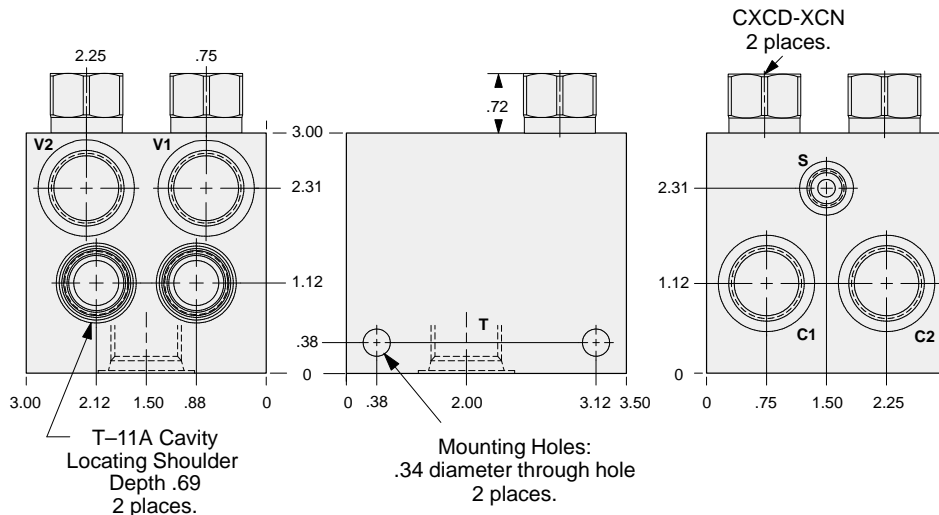

Ports C1, C2, & V1, V2	Port S	Port T	ALUMINUM		DUCTILE IRON	
			Part Number	List Price	Part Number	List Price
.375 NPTF	.25 NPTF	.50 NPTF	ENB		ENB/S	
.50 NPTF	.25 NPTF	.50 NPTF	ENC		ENC/S	
SAE-8	SAE-4	SAE-10	ENJ		ENJ/S	
SAE-10	SAE-4	SAE-10	ENK		ENK/S	
.375 BSPP	.25 BSPP	.50 BSPP	ENU		ENU/S	
.50 BSPP	.25 BSPP	.50 BSPP	ENV		ENV/S	

*Discharge oil returns to tank through port T.



LINE MOUNT BODIES



- Aluminum rated to 3000 psi.
- Ductile Iron rated to 5000 psi.

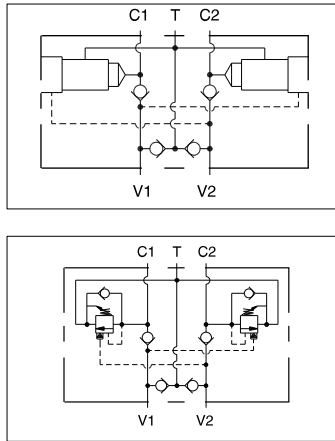

Two cavity dual load control body with make-up checks.

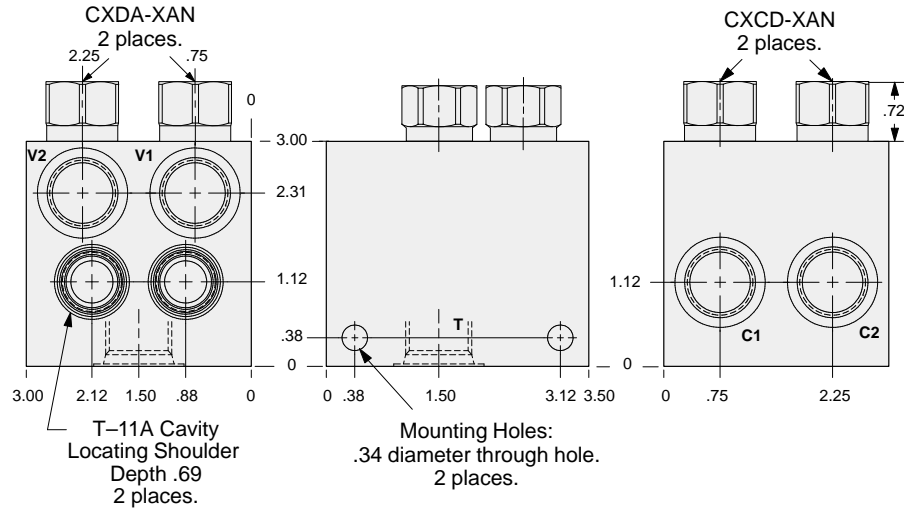

TYPICAL CARTRIDGES USED WITH THIS BODY

- CBCA - *** Page 4.10
CBCG - *** Page 4.12
CBCH - *** Page 4.14

Cartridge seal type determines check valve seal type.

Instructions for ordering complete cartridge and body assemblies. Page v

Pressure ratings, material specifications. Page 11.02

Ports C1, C2, & V1, V2	Port T	ALUMINUM		DUCTILE IRON	
		Part Number	List Price	Part Number	List Price
.375 NPTF	.50 NPTF	EPB		EPB/S	
.50 NPTF	.50 NPTF	EPC		EPC/S	
SAE-8	SAE-10	EPJ		EPJ/S	
SAE-10	SAE-10	EPK		EPK/S	
.375 BSPP	.50 BSPP	EPU		EPU/S	
.50 BSPP	.50 BSPP	EPV		EPV/S	

*Discharge oil returns to tank through directional valve or port T.

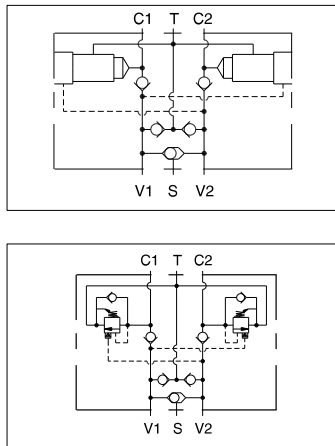

Two cavity dual load control body with make-up checks and shuttle.

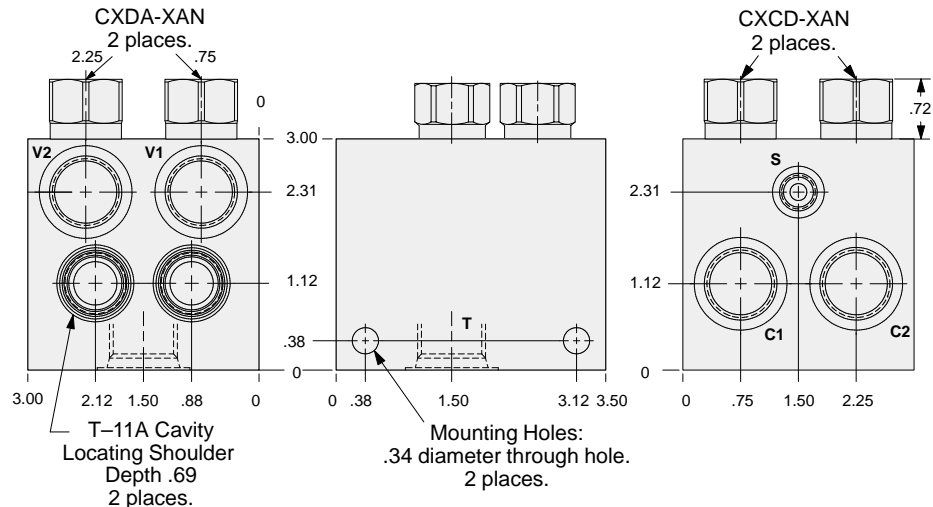

TYPICAL CARTRIDGES USED WITH THIS BODY

- CBCA - *** Page 4.10
CBCG - *** Page 4.12
CBCH - *** Page 4.14

Cartridge seal type determines check valve seal type.

Instructions for ordering complete cartridge and body assemblies. Page v

Pressure ratings, material specifications. Page 11.02

Ports C1, C2, & V1, V2	Port S	Port T	ALUMINUM		DUCTILE IRON	
			Part Number	List Price	Part Number	List Price
.375 NPTF	.25 NPTF	.50 NPTF	EQB		EQB/S	
.50 NPTF	.25 NPTF	.50 NPTF	EQC		EQC/S	
SAE-8	SAE-4	SAE-10	EQJ		EQJ/S	
SAE-10	SAE-4	SAE-10	EQK		EQK/S	
.375 BSPP	.25 BSPP	.50 BSPP	EQU		EQU/S	
.50 BSPP	.25 BSPP	.50 BSPP	EQV		EQV/S	

*Discharge oil returns to tank through directional valve or port T.



LINE MOUNT BODIES



- Aluminum rated to 3000 psi.
- Ductile Iron rated to 5000 psi.

Two cavity dual sequence body with reverse free flow checks.

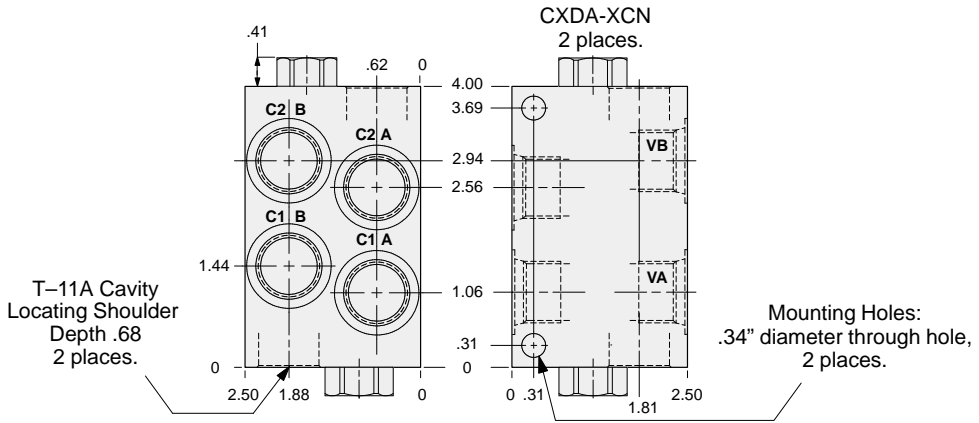
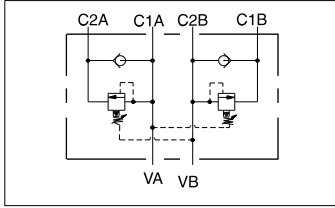
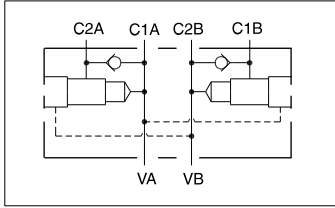

TYPICAL CARTRIDGES USED WITH THIS BODY

RSDC - *** Page 2.06
SQDB - *** Page 2.08

Cartridge seal type determines check valve seal type.

Instructions for ordering complete cartridge and body assemblies. Page v

Pressure ratings, material specifications. Page 11.02

All Ports	ALUMINUM		DUCTILE IRON	
	Part Number	List Price	Part Number	List Price
.25 NPTF	E8A		E8A/S	
.375 NPTF	E8B		E8B/S	
.50 NPTF	E8C		E8C/S	
SAE-6	E8I		E8I/S	
SAE-8	E8J		E8J/S	
SAE-10	E8K		E8K/S	
.25 BSPP	E8T		E8T/S	
.375 BSPP	E8U		E8U/S	
.50 BSPP	E8V		E8V/S	

Four cavity triple sequence body with reverse free flow checks.

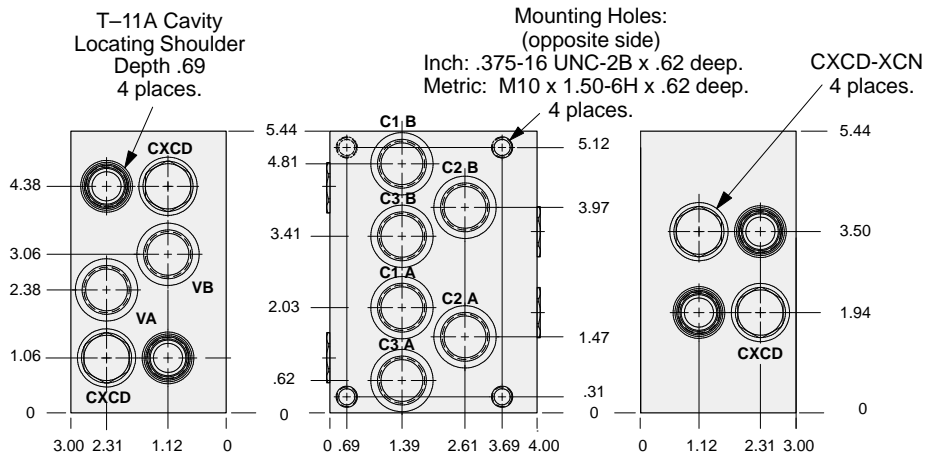
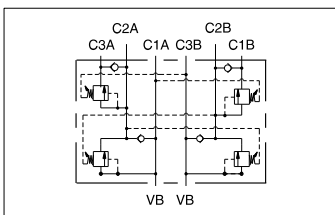
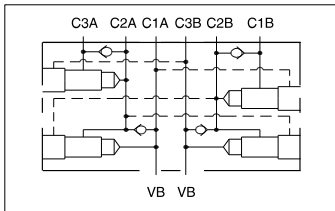

TYPICAL CARTRIDGES USED WITH THIS BODY

RSDC - *** Page 2.06
SQDB - *** Page 2.08

Cartridge seal type determines check valve seal type.

Instructions for ordering complete cartridge and body assemblies. Page v

Pressure ratings, material specifications. Page 11.02

Mounting Hole Dimensions	All Ports	ALUMINUM		DUCTILE IRON	
		Part Number	List Price	Part Number	List Price
Inch	.375 NPTF	E9B		E9B/S	
Inch	.50 NPTF	E9C		E9C/S	
Inch	SAE-8	E9J		E9J/S	
Inch	SAE-10	E9K		E9K/S	
Metric	.375 BSPP	E9U		E9U/S	
Metric	.50 BSPP	E9V		E9V/S	

S1
T11A



LINE MOUNT BODIES

- Aluminum rated to 3000 psi.
- Ductile Iron rated to 5000 psi.

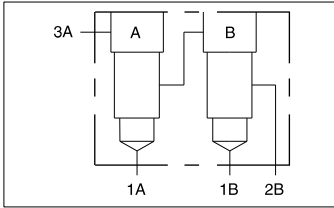

Two cavity load-sensing body with three signal input.

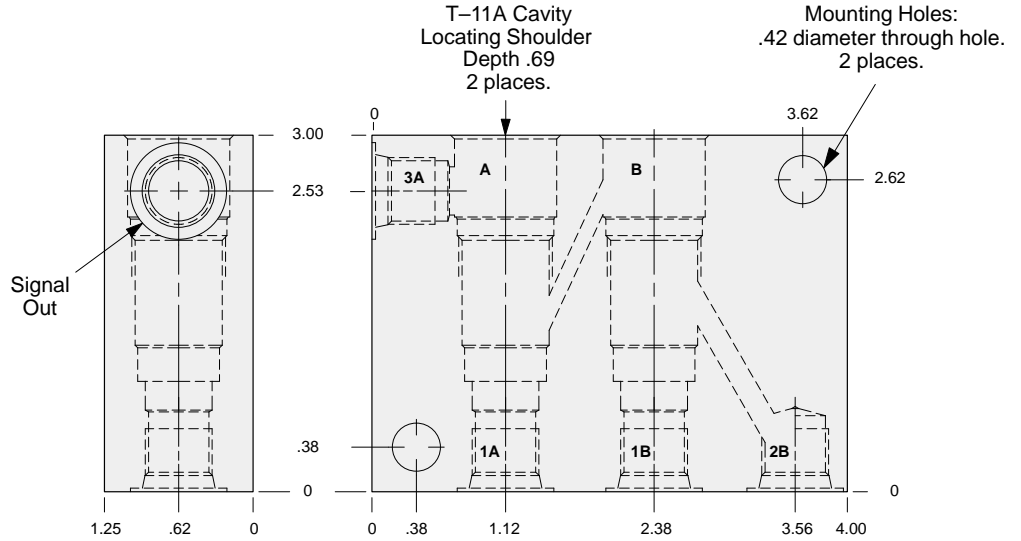

TYPICAL CARTRIDGES USED WITH THIS BODY

CSAB - *** Page 10.08
 CDAB - *** Page 10.10

Instructions for ordering complete cartridge and body assemblies. Page v

Pressure ratings, material specifications. Page 11.02

All Ports	ALUMINUM		DUCTILE IRON	
	Part Number	List Price	Part Number	List Price
.25 NPTF	XVV		XVV/S	
SAE-6	XVW		XVW/S	
.25 BSPP	XVX		XVX/S	

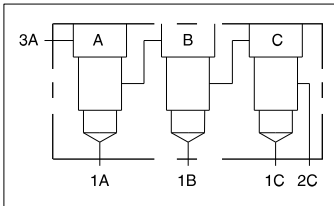

Three cavity load-sensing body with four signal input.

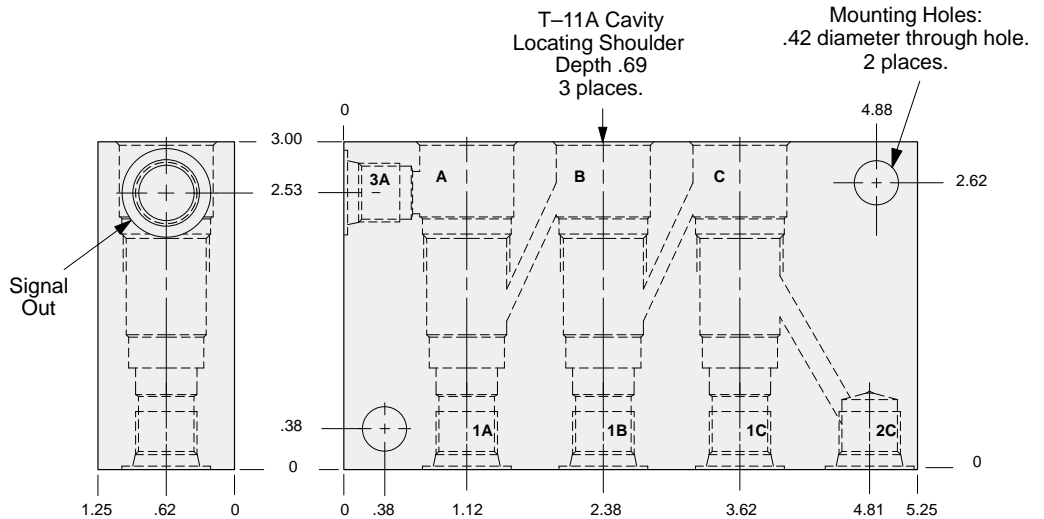

TYPICAL CARTRIDGES USED WITH THIS BODY

CSAB - *** Page 10.08
 CDAB - *** Page 10.10

Instructions for ordering complete cartridge and body assemblies. Page v

Pressure ratings, material specifications. Page 11.02

All Ports	ALUMINUM		DUCTILE IRON	
	Part Number	List Price	Part Number	List Price
.25 NPTF	XVR		XVR/S	
SAE-6	XVS		XVS/S	
.25 BSPP	XVT		XVT/S	

S1
T11A



LINE MOUNT BODIES



- Aluminum rated to 3000 psi.
- Ductile Iron rated to 5000 psi.

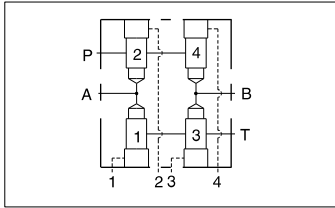

Four cavity four-way logic body for directional applications.

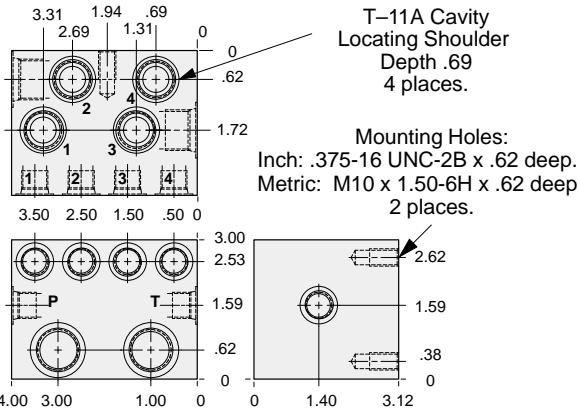

TYPICAL CARTRIDGES USED WITH THIS BODY

- LODC - *** Page 9.08
- LKDC - *** Page 9.10
- LPDC - *** Page 9.12
- LRDC - *** Page 9.14

Instructions for ordering complete cartridge and body assemblies. Page v

Pressure ratings, material specifications. Page 11.02

Mounting Hole Dimensions	Ports 1 & 2, 3 & 4	Ports A & B P & T	ALUMINUM		DUCTILE IRON	
			Part Number	List Price	Part Number	List Price
Inch	.25 NPTF	.25 NPTF	YRZ		YRZ/S	
Inch	.25 NPTF	.375 NPTF	YRY		YRY/S	
Inch	.25 NPTF	.50 NPTF	YRX		YRX/S	
Inch	SAE-6	SAE-6	YRW		YRW/S	
Inch	SAE-6	SAE-8	YRV		YRV/S	
Inch	SAE-6	SAE-10	YRT		YRT/S	
Metric	.25 BSPP	.25 BSPP	YRP		YRP/S	
Metric	.25 BSPP	.375 BSPP	YRM		YRM/S	
Metric	.25 BSPP	.50 BSPP	YRQ		YRQ/S	

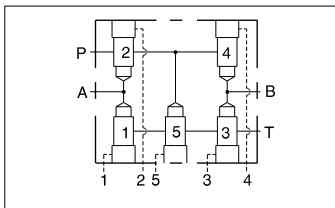

Five cavity four-way logic body for directional applications.

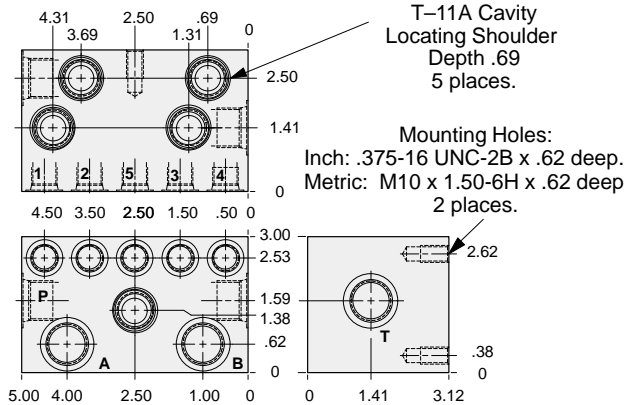

TYPICAL CARTRIDGES USED WITH THIS BODY

- LODC - *** Page 9.08
- LKDC - *** Page 9.10
- LPDC - *** Page 9.12
- LRDC - *** Page 9.14

Instructions for ordering complete cartridge and body assemblies. Page v

Pressure ratings, material specifications. Page 11.02

Mounting Hole Dimensions	Ports 1, 2, 3, 4, & 5	Ports A & B P & T	ALUMINUM		DUCTILE IRON	
			Part Number	List Price	Part Number	List Price
Inch	.25 NPTF	.25 NPTF	YQZ		YQZ/S	
Inch	.25 NPTF	.375 NPTF	YQY		YQY/S	
Inch	.25 NPTF	.50 NPTF	YQX		YQX/S	
Inch	SAE-6	SAE-6	YQW		YQW/S	
Inch	SAE-6	SAE-8	YQV		YQV/S	
Inch	SAE-6	SAE-10	YQT		YQT/S	
Metric	.25 BSPP	.25 BSPP	YQP		YQP/S	
Metric	.25 BSPP	.375 BSPP	YQM		YQM/S	
Metric	.25 BSPP	.50 BSPP	YQQ		YQQ/S	

S1
T11A



LINE MOUNT BODIES



- Aluminum rated to 3000 psi.
- Ductile Iron rated to 5000 psi.

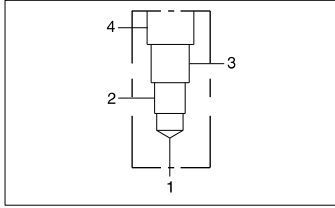

90 degree body.

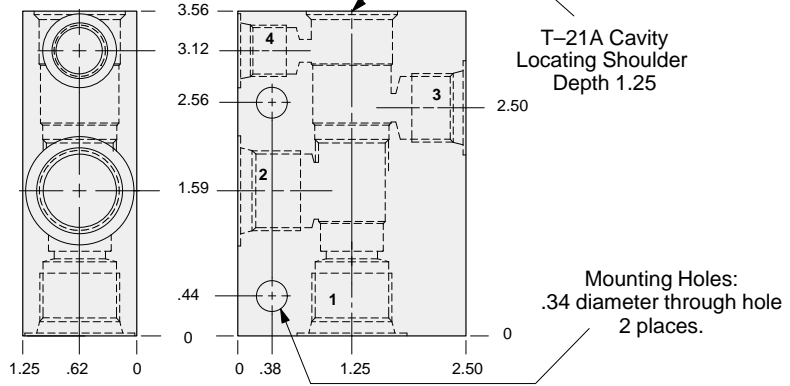

TYPICAL CARTRIDGES USED WITH THIS BODY

RVCD - ***	Page 1.20
PVDA - ***	Page 3.14
PVDB - ***	Page 3.16
CWCA - ***	Page 4.18
CWCG - ***	Page 4.20
CVCV - ***	Page 4.22
FVCA - ***	Page 6.04
DPBM - ***	Page 8.10
DPBN - ***	Page 8.11
DPBO - ***	Page 8.12
DPBP - ***	Page 8.13

Instructions for ordering complete cartridge and body assemblies. Page v

Pressure ratings, material specifications. Page 11.02

Ports 1 & 2	Port 3	Port 4	ALUMINUM		DUCTILE IRON	
			Part Number	List Price	Part Number	List Price
.25 NPTF	.25 NPTF	.25 NPTF	MAA		MAA/S	
.375 NPTF	.375 NPTF	.25 NPTF	MAB		MAB/S	
.50 NPTF	.375 NPTF	.25 NPTF	MAC		MAC/S	
SAE-6	SAE-6	SAE-6	MAI		MAI/S	
SAE-8	SAE-8	SAE-6	MAJ		MAJ/S	
SAE-10	SAE-8	SAE-6	MAK		MAK/S	
.25 BSPP	.25 BSPP	.25 BSPP	MAT		MAT/S	
.375 BSPP	.375 BSPP	.25 BSPP	MAU		MAU/S	
.50 BSPP	.375 BSPP	.25 BSPP	MAV		MAV/S	

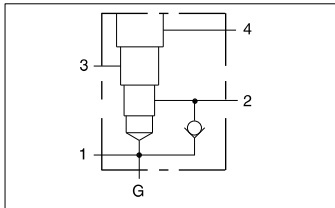

Body with reverse free flow check and gage port for reducing/relieving applications.

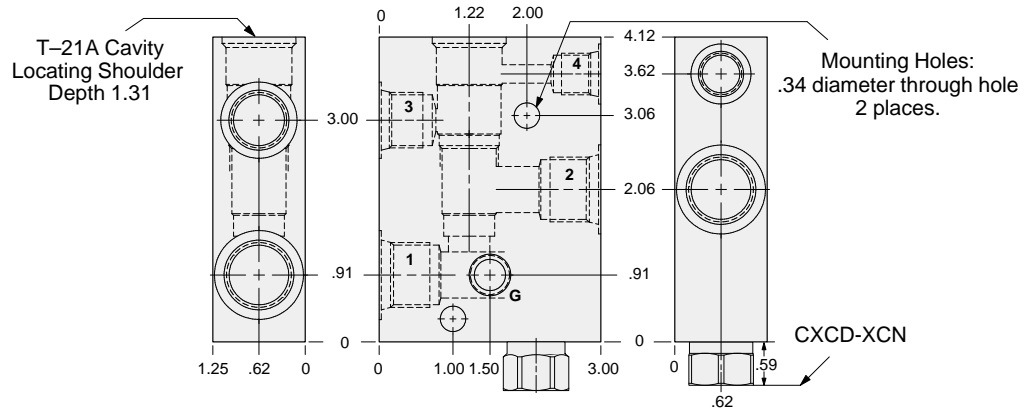

TYPICAL CARTRIDGES USED WITH THIS BODY

PVDA - ***	Page 3.14
PVDB - ***	Page 3.16

Cartridge seal type determines check valve seal type.

Instructions for ordering complete cartridge and body assemblies. Page v

Pressure ratings, material specifications. Page 11.02

Ports 1 & 2	Port 3	Port 4	Gage Port	ALUMINUM		DUCTILE IRON	
				Part Number	List Price	Part Number	List Price
.25 NPTF	.25 NPTF	.25 NPTF	.25 NPTF	M4A		M4A/S	
.375 NPTF	.375 NPTF	.375 NPTF	.25 NPTF	M4B		M4B/S	
.50 NPTF	.50 NPTF	.50 NPTF	.25 NPTF	M4C		M4C/S	
SAE-6	SAE-6	SAE-6	.25 NPTF	M4I		M4I/S	
SAE-8	SAE-8	SAE-6	.25 NPTF	M4J		M4J/S	
SAE-10	SAE-8	SAE-6	.25 NPTF	M4K		M4K/S	
.25 BSPP	.25 BSPP	.25 BSPP	.25 BSPP	M4T		M4T/S	
.375 BSPP	.375 BSPP	.25 BSPP	.25 BSPP	M4U		M4U/S	
.50 BSPP	.375 BSPP	.25 BSPP	.25 BSPP	M4V		M4V/S	

S1
T21A



LINE MOUNT BODIES



- Aluminum rated to 3000 psi.
- Ductile Iron rated to 5000 psi.

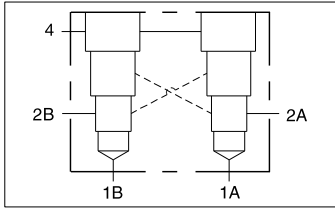

Two cavity 90 degree cross-piloted body with common port 4 for load control applications.

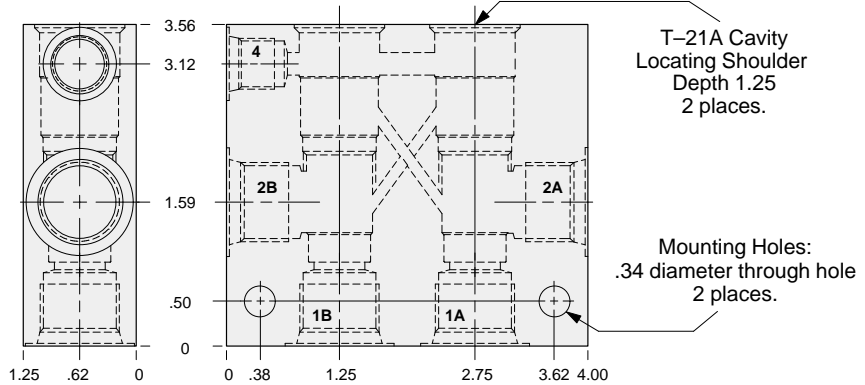

TYPICAL CARTRIDGES USED WITH THIS BODY

- CWCA - *** Page 4.18
 CWCG - *** Page 4.20
 CVCV - *** Page 4.22

Instructions for ordering complete cartridge and body assemblies. Page v

Pressure ratings, material specifications. Page 11.02

Main Ports 1A,1B 2A,2B	Port 4	ALUMINUM		DUCTILE IRON	
		Part Number	List Price	Part Number	List Price
.25 NPTF	.25 NPTF	XPA		XPA/S	
.375 NPTF	.25 NPTF	XPB		XPB/S	
.50 NPTF	.25 NPTF	XPC		XPC/S	
SAE-6	SAE-6	XPI		XPI/S	
SAE-8	SAE-6	XPJ		XPJ/S	
SAE-10	SAE-6	XPK		XPK/S	
.25 BSPP	.25 BSPP	XPT		XPT/S	
.375 BSPP	.25 BSPP	XPU		XPU/S	
.50 BSPP	.25 BSPP	XPV		XPV/S	

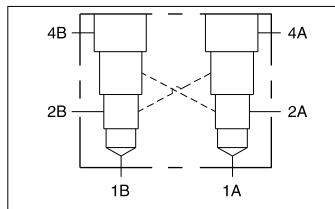

Two cavity 90 degree cross-piloted body with independent port 4 for load control applications.

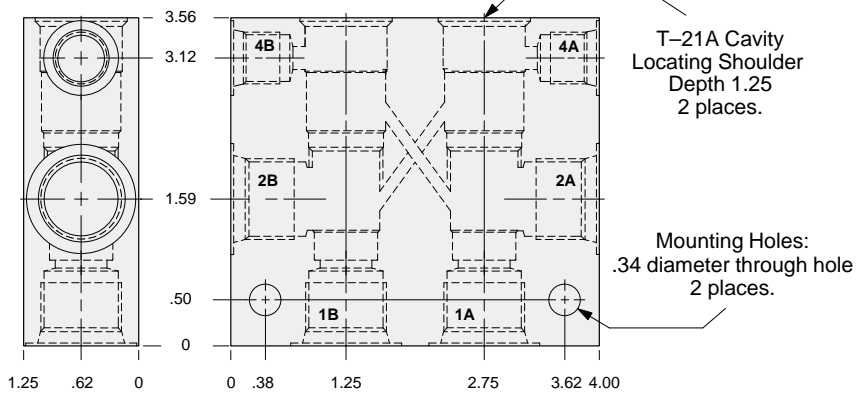

TYPICAL CARTRIDGES USED WITH THIS BODY

- CWCA - *** Page 4.18
 CWCG - *** Page 4.20
 CVCV - *** Page 4.22

Instructions for ordering complete cartridge and body assemblies. Page v

Pressure ratings, material specifications. Page 11.02

Main Ports 1A,1B 2A,2B	Ports 4A & 4B	ALUMINUM		DUCTILE IRON	
		Part Number	List Price	Part Number	List Price
.25 NPTF	.25 NPTF	XFA		XFA/S	
.375 NPTF	.25 NPTF	XFB		XFB/S	
.50 NPTF	.25 NPTF	XFC		XFC/S	
SAE-6	SAE-6	XFI		XFI/S	
SAE-8	SAE-6	XFJ		XFJ/S	
SAE-10	SAE-6	XFK		XFK/S	
.25 BSPP	.25 BSPP	XFT		XFT/S	
.375 BSPP	.25 BSPP	XFU		XFU/S	
.50 BSPP	.25 BSPP	XFV		XFV/S	

S1
T21A



LINE MOUNT BODIES



- Aluminum rated to 3000 psi.
- Ductile Iron rated to 5000 psi.

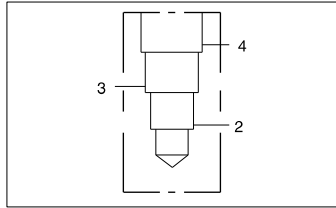

TYPICAL CARTRIDGES USED WITH THIS BODY

FSBD - ***	Page 7.08
FSCD - ***	Page 7.08
FSBA - ***	Page 7.10
FSCA - ***	Page 7.10
FSBS - ***	Page 7.12
FSCS - ***	Page 7.12
FSCH - ***	Page 7.14
DSCH - ***	Page 10.06

Instructions for ordering complete cartridge and body assemblies. Page v

Pressure ratings, material specifications. Page 11.02

Body for flow divider/combiner applications.

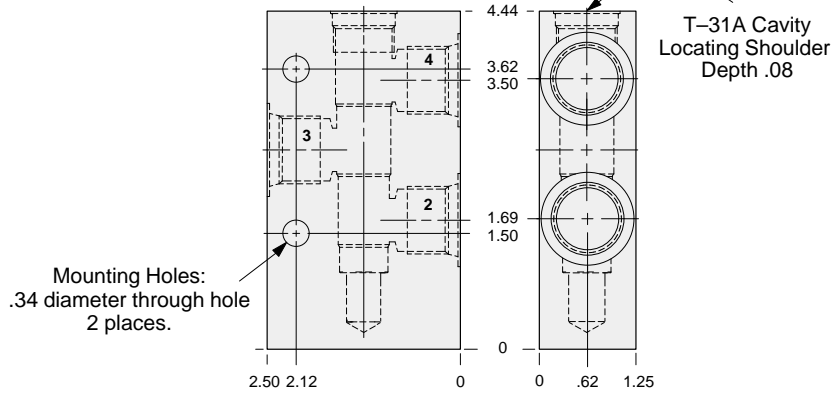

Ports 2, 3, & 4	ALUMINUM		DUCTILE IRON	
	Part Number	List Price	Part Number	List Price
.25 NPTF	MMA		MMA/S	
.375 NPTF	MMB		MMB/S	
.50 NPTF	MMC		MMC/S	
SAE-6	MMI		MMI/S	
SAE-8	MMJ		MMJ/S	
SAE-10	MMK		MMK/S	
.25 BSPP	MMT		MMT/S	
.375 BSPP	MMU		MMU/S	
.50 BSPP	MMV		MMV/S	

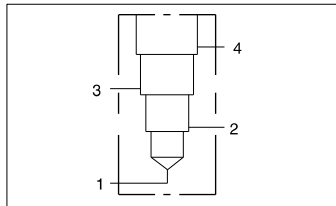

Four port body.

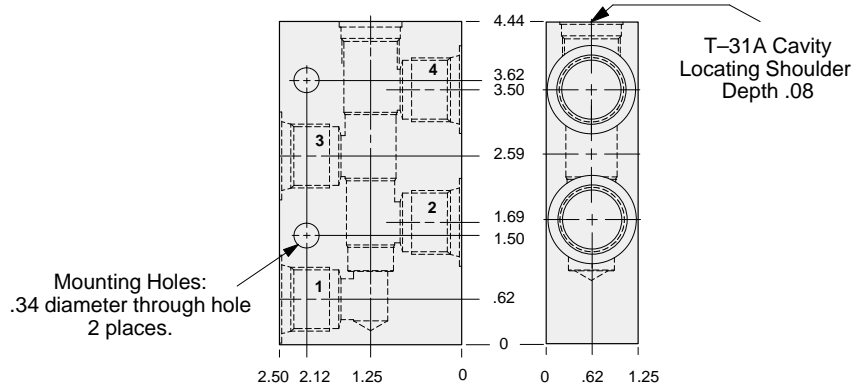

Instructions for ordering complete cartridge and body assemblies. Page v

Pressure ratings, material specifications. Page 11.02

Ports 2, 3, & 4	ALUMINUM		DUCTILE IRON	
	Part Number	List Price	Part Number	List Price
.25 NPTF	MNA		MNA/S	
.375 NPTF	MNB		MNB/S	
.50 NPTF	MNC		MNC/S	
SAE-6	MNI		MNI/S	
SAE-8	MNJ		MNJ/S	
SAE-10	MNK		MNK/S	
.25 BSPP	MNT		MNT/S	
.375 BSPP	MNU		MNU/S	
.50 BSPP	MNV		MNV/S	

S1
T31A



LINE MOUNT BODIES



- Aluminum rated to 3000 psi.
- Ductile Iron rated to 5000 psi.

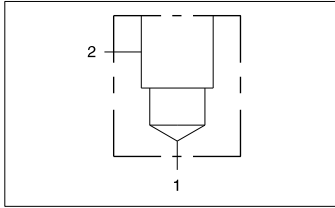

90 degree body.

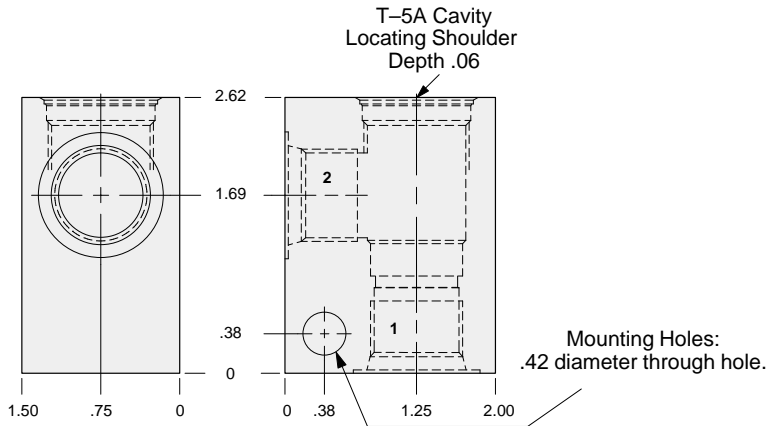

TYPICAL CARTRIDGES USED WITH THIS BODY

CXFA - ***	Page 5.08
CXED - ***	Page 5.10
NFDC - ***	Page 5.12
CNEC - ***	Page 5.14
NCEB - ***	Page 5.16
NCEC - ***	Page 5.18
FXDA - ***	Page 5.20
FCDB - ***	Page 5.22
FDCB - ***	Page 5.24
FQEA - ***	Page 10.14

Instructions for ordering complete cartridge and body assemblies. Page v

Pressure ratings, material specifications. Page 11.02

Ports 1 & 2	ALUMINUM		DUCTILE IRON	
	Part Number	List Price	Part Number	List Price
.25 NPTF	DAA		DAA/S	
.375 NPTF	DAB		DAB/S	
.50 NPTF	DAC		DAC/S	
SAE-6	DAI		DAI/S	
SAE-8	DAJ		DAJ/S	
SAE-10	DAK		DAK/S	
.25 BSPP	DAT		DAT/S	
.375 BSPP	DAU		DAU/S	
.50 BSPP	DAV		DAV/S	

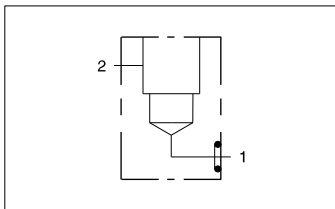

Direct mount .75" SAE Code 61 body

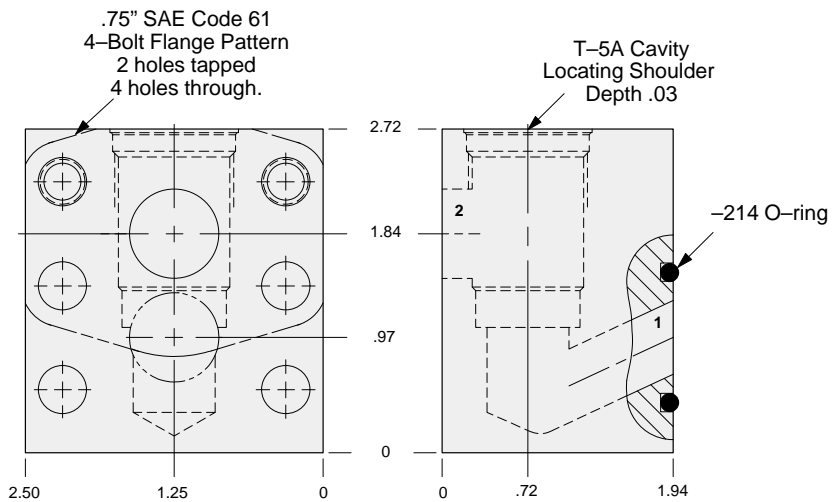

TYPICAL CARTRIDGES USED WITH THIS BODY

CXFA - ***	Page 5.08
CXED - ***	Page 5.10
NFDC - ***	Page 5.12
CNEC - ***	Page 5.14
NCEB - ***	Page 5.16
NCEC - ***	Page 5.18
FXDA - ***	Page 5.20
FCDB - ***	Page 5.22
FDCB - ***	Page 5.24
FQEA - ***	Page 10.14

Cartridge seal type determines O-ring type.

Instructions for ordering complete cartridge and body assemblies. Page v

Pressure ratings, material specifications. Page 11.02

Mounting Hole Dimensions	ALUMINUM		DUCTILE IRON	
	Part Number	List Price	Part Number	List Price
Inch	ZKS		ZKS/S	
Metric	ZKS/M		ZKS/T	

S2
T5A



LINE MOUNT BODIES



- Aluminum rated to 3000 psi.
- Ductile Iron rated to 5000 psi.

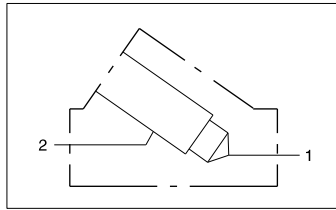

Inline body.

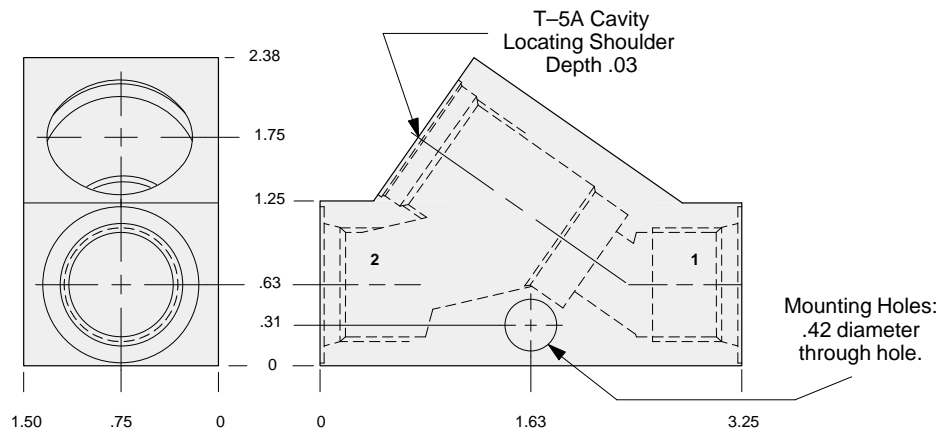

TYPICAL CARTRIDGES USED WITH THIS BODY

CXFA - ***	Page 5.08
CXED - ***	Page 5.10
NFDC - ***	Page 5.12
CNEC - ***	Page 5.14
NCEB - ***	Page 5.16
NCEC - ***	Page 5.18
FXDA - ***	Page 5.20
FCDB - ***	Page 5.22
FDCB - ***	Page 5.24
FQEA - ***	Page 10.14

Instructions for ordering complete cartridge and body assemblies. Page v

Pressure ratings, material specifications. Page 11.02

Ports 1 & 2	ALUMINUM		DUCTILE IRON	
	Part Number	List Price	Part Number	List Price
.375 NPTF	DCB		DCB/S	
.50 NPTF	DCC		DCC/S	
SAE-6	DCI		DCI/S	
SAE-8	DCJ		DCJ/S	
SAE-10	DCK		DCK/S	
.375 BSPP	DCU		DCU/S	
.50 BSPP	DCV		DCV/S	

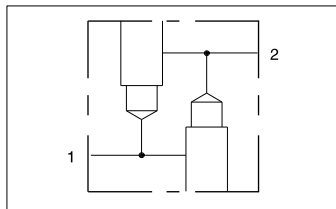

Two cavity body.

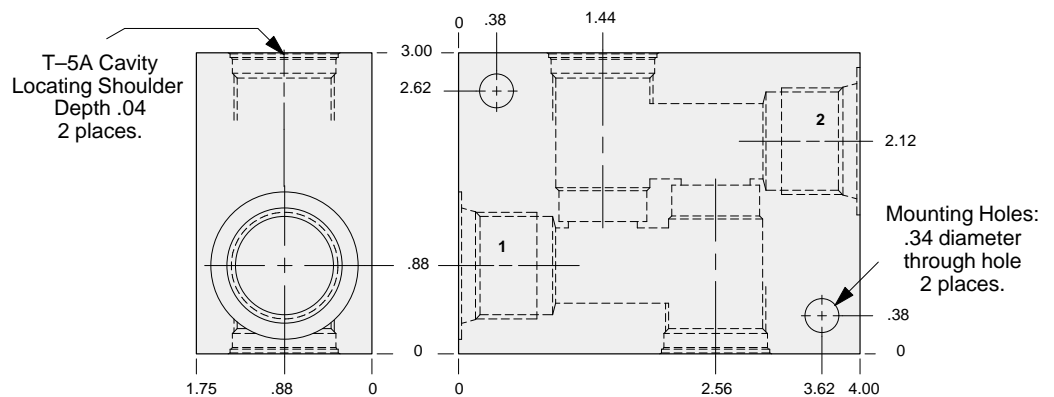

TYPICAL CARTRIDGES USED WITH THIS BODY

CXFA - ***	Page 5.08
NFDC - ***	Page 5.12
FXDA - ***	Page 5.20

Instructions for ordering complete cartridge and body assemblies. Page v

Pressure ratings, material specifications. Page 11.02

Ports 1 & 2	ALUMINUM		DUCTILE IRON	
	Part Number	List Price	Part Number	List Price
.375 NPTF	XWA		XWA/S	
.50 NPTF	XWB		XWB/S	
.75 NPTF	XWC		XWC/S	
SAE-8	XWD		XWD/S	
SAE-10	XWF		XWF/S	
SAE-12	XWG		XWG/S	
.375 BSPP	XWH		XWH/S	
.50 BSPP	XWJ		XWJ/S	
.75 BSPP	XWK		XWK/S	

S2
T5A



LINE MOUNT BODIES



- Aluminum rated to 3000 psi.
- Ductile Iron rated to 5000 psi.

Rectifier body.

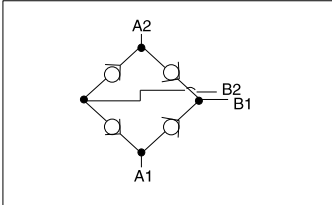
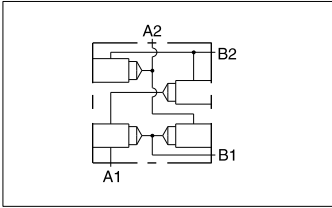

TYPICAL CARTRIDGES USED WITH THIS BODY

CXFA - *** Page 5.08

Instructions for ordering complete cartridge and body assemblies. Page v

Pressure ratings, material specifications. Page 11.02

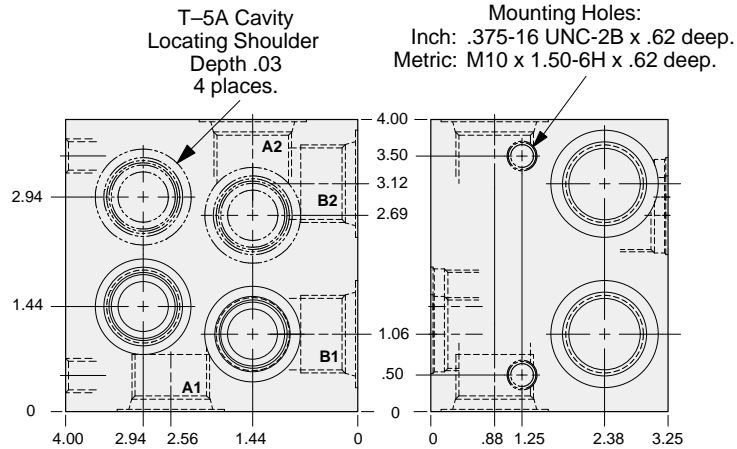

Mounting Hole Dimensions	All Ports	ALUMINUM		DUCTILE IRON	
		Part Number	List Price	Part Number	List Price
Inch	.50 NPTF	YSL		YSL/S	
Inch	.75 NPTF	YSM		YSM/S	
Inch	SAE-10	YSN		YSN/S	
Inch	SAE-12	YSO		YSO/S	
Metric	.50 BSPP	YSP		YSP/S	
Metric	.75 BSPP	YSQ		YSQ/S	

Body with reverse free flow check.

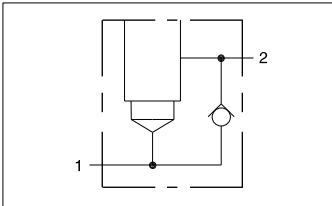

TYPICAL CARTRIDGES USED WITH THIS BODY

NFDC - *** Page 5.12

FXDA - *** Page 5.20

Cartridge seal type determines check valve seal type.

Instructions for ordering complete cartridge and body assemblies. Page v

Pressure ratings, material specifications. Page 11.02

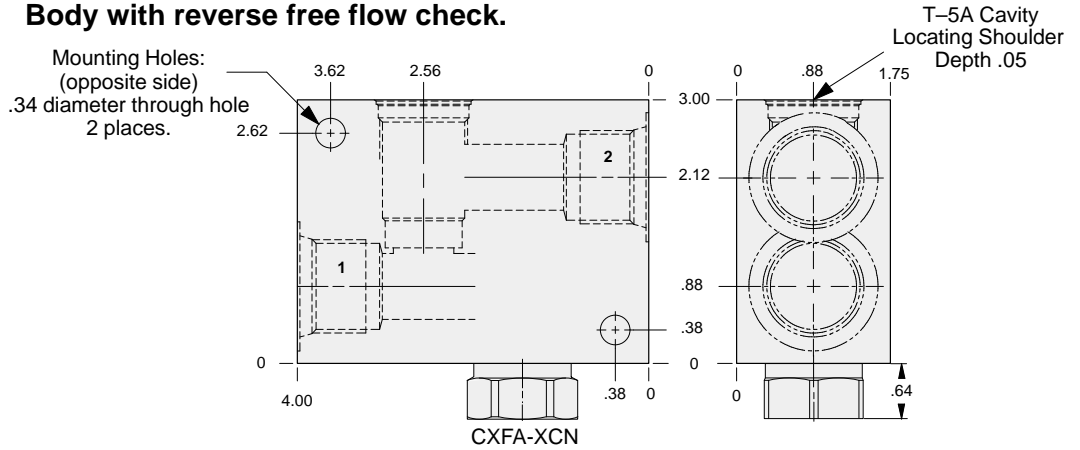

Ports 1 & 2	ALUMINUM		DUCTILE IRON	
	Part Number	List Price	Part Number	List Price
.375 NPTF	DNB		DNB/S	
.50 NPTF	DNC		DNC/S	
.75 NPTF	DND		DND/S	
SAE-8	DNJ		DNJ/S	
SAE-10	DNK		DNK/S	
SAE-12	DNL		DNL/S	
.375 BSPP	DNU		DNU/S	
.50 BSPP	DNV		DNV/S	
.75 BSPP	DNW		DNW/S	

S2
T5A



LINE MOUNT BODIES



- Aluminum rated to 3000 psi.
- Ductile Iron rated to 5000 psi.

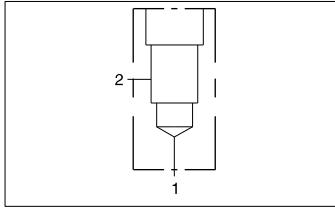

90 degree body.

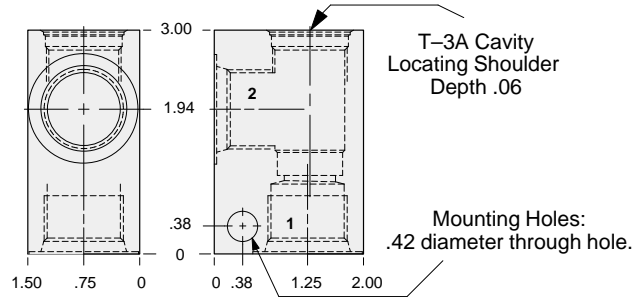

TYPICAL CARTRIDGES USED WITH THIS BODY

RPGC - ***	Page 1.06
RPGE - ***	Page 1.08
RDFA - ***	Page 1.10
RQGB - ***	Page 1.12
RPGD - ***	Page 1.14
RBAA - ***	Page 1.16
RBAB - ***	Page 1.14
NQEB - ***	Page 10.16

Instructions for ordering complete cartridge and body assemblies. Page v

Pressure ratings, material specifications. Page 11.02

Ports 1 & 2	ALUMINUM		DUCTILE IRON	
	Part Number	List Price	Part Number	List Price
.25 NPTF	CAA		CAA/S	
.375 NPTF	CAB		CAB/S	
.50 NPTF	CAC		CAC/S	
.75 NPTF	CAD		CAD/S	
SAE-4	CAH		CAH/S	
SAE-6	CAI		CAI/S	
SAE-8	CAJ		CAJ/S	
SAE-10	CAK		CAK/S	
SAE-12	CAL		CAL/S	
.25 BSPP	CAT		CAT/S	
.375 BSPP	CAU		CAU/S	
.50 BSPP	CAV		CAV/S	
.75 BSPP	CAW		CAW/S	

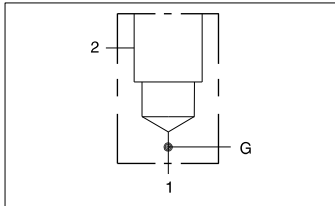

90 degree body with gage port.

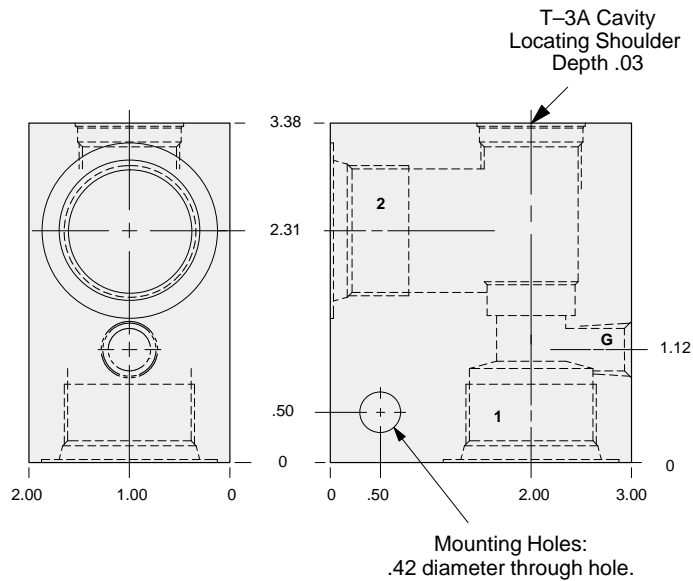

TYPICAL CARTRIDGES USED WITH THIS BODY

RPGC - ***	Page 1.06
RPGE - ***	Page 1.08
RDFA - ***	Page 1.10
RQGB - ***	Page 1.12
RPGD - ***	Page 1.14
NQEB - ***	Page 10.16

Instructions for ordering complete cartridge and body assemblies. Page v

Pressure ratings, material specifications. Page 11.02

Ports 1 & 2	Gage Port	ALUMINUM		DUCTILE IRON	
		Part Number	List Price	Part Number	List Price
1.00 NPTF	.25 NPTF	CAE		CAE/S	
SAE-16	.25 NPTF	CAM		CAM/S	
1.00 BSPP	.25 BSPP	CAX		CAX/S	



LINE MOUNT BODIES



- Aluminum rated to 3000 psi.
- Ductile Iron rated to 5000 psi.

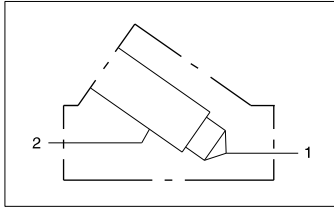

Inline body.

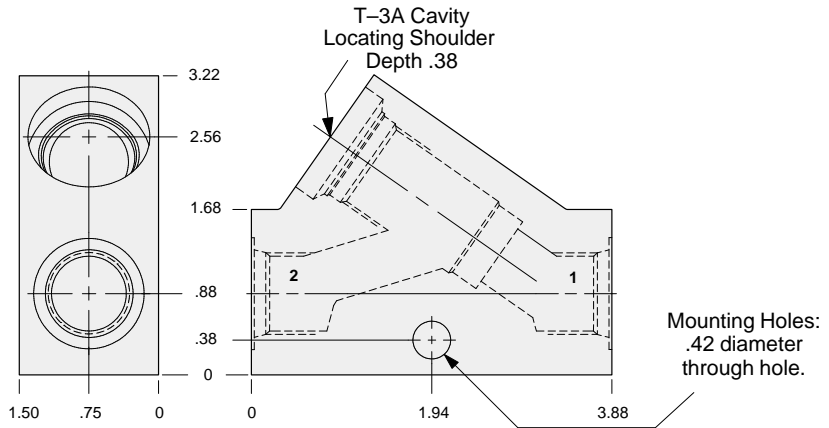

TYPICAL CARTRIDGES USED WITH THIS BODY

RPGC - ***	Page 1.06
RPGE - ***	Page 1.08
RDFA - ***	Page 1.10
RQGB - ***	Page 1.12
RPGD - ***	Page 1.14
RBAA - ***	Page 1.14
RBAB - ***	Page 1.16
NQEB - ***	Page 10.16

Instructions for ordering complete cartridge and body assemblies. Page v

Pressure ratings, material specifications. Page 11.02

Ports 1 & 2	ALUMINUM		DUCTILE IRON	
	Part Number	List Price	Part Number	List Price
.375 NPTF	CGB		CGB/S	
.50 NPTF	CGC		CGC/S	
.75 NPTF	CGD		CGD/S	
SAE-6	CGI		CGI/S	
SAE-8	CGJ		CGJ/S	
SAE-10	CGK		CGK/S	
.375 BSPP	CGU		CGU/S	
.50 BSPP	CGV		CGV/S	
.75 BSPP	CGW		CGW/S	

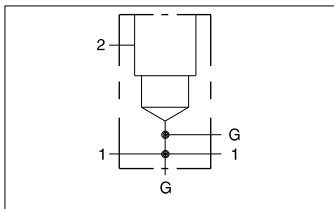

Through port body with gage ports.

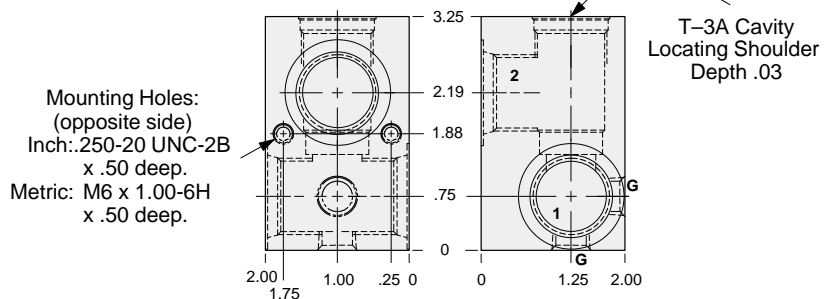

TYPICAL CARTRIDGES USED WITH THIS BODY

RPGC - ***	Page 1.06
RPGE - ***	Page 1.08
RDFA - ***	Page 1.10
RQGB - ***	Page 1.12
RPGD - ***	Page 1.14
RBAA - ***	Page 1.14
RBAB - ***	Page 1.16
NQEB - ***	Page 10.16

Instructions for ordering complete cartridge and body assemblies. Page v

Pressure ratings, material specifications. Page 11.02

Mounting Hole Dimensions	Ports 1 & 2	Gage Ports	ALUMINUM		DUCTILE IRON	
			Part Number	List Price	Part Number	List Price
Inch	.25 NPTF	.25 NPTF	CEA		CEA/S	
Inch	.375 NPTF	.25 NPTF	CEB		CEB/S	
Inch	.50 NPTF	.25 NPTF	CEC		CEC/S	
Inch	.75 NPTF	.25 NPTF	CED		CED/S	
Inch	SAE-4	.25 NPTF	CEH		CEH/S	
Inch	SAE-6	.25 NPTF	CEI		CEI/S	
Inch	SAE-8	.25 NPTF	CEJ		CEJ/S	
Inch	SAE-10	.25 NPTF	CEK		CEK/S	
Inch	SAE-12	.25 NPTF	CEL		CEL/S	
Metric	.25 BSPP	.25 BSPP	CET		CET/S	
Metric	.375 BSPP	.25 BSPP	CEU		CEU/S	
Metric	.50 BSPP	.25 BSPP	CEV		CEV/S	
Metric	.75 BSPP	.25 BSPP	CEW		CEW/S	



LINE MOUNT BODIES



- Aluminum rated to 3000 psi.
- Ductile Iron rated to 5000 psi.

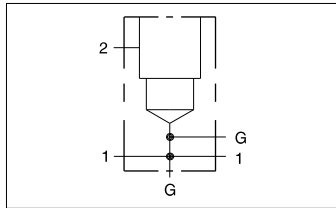

Through port body with gage ports.

TYPICAL CARTRIDGES USED WITH THIS BODY

RPGC - ***	Page 1.06
RPGE - ***	Page 1.08
RDFA - ***	Page 1.10
RQGB - ***	Page 1.12
RPGD - ***	Page 1.14
NQEB - ***	Page 10.16

Instructions for ordering complete cartridge and body assemblies. Page v

Pressure ratings, material specifications. Page 11.02

Mounting Holes:
Inch: .250-20 UNC-2B x .50 deep.
Metric: M6 x 1.00-6H x .50 deep.

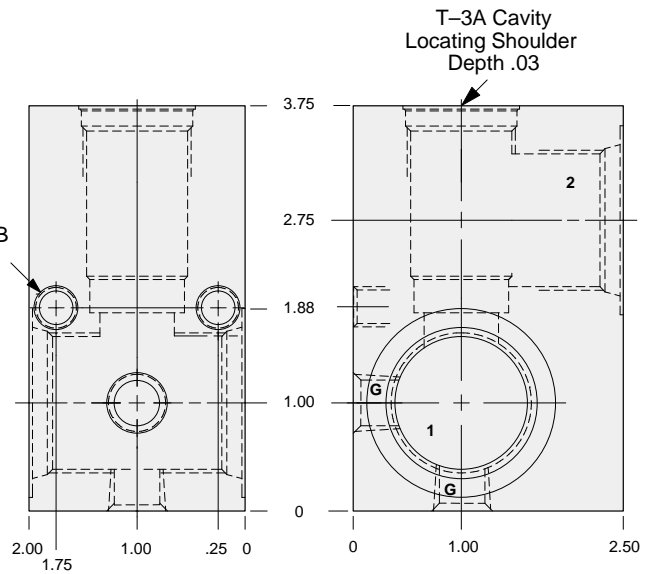

Mounting Hole Dimensions	Ports 1 & 2	Gage Ports	ALUMINUM		DUCTILE IRON	
			Part Number	List Price	Part Number	List Price
Inch	1.00 NPTF	.25 NPTF	CEE		CEE/S	
Inch	SAE-16	.25 NPTF	CEM		CEM/S	
Metric	1.00 BSPP	.25 BSPP	CEX		CEX/S	



LINE MOUNT BODIES



- Aluminum rated to 3000 psi.
- Ductile Iron rated to 5000 psi.

90 degree .75" SAE Code 61 flange port body with gage port.

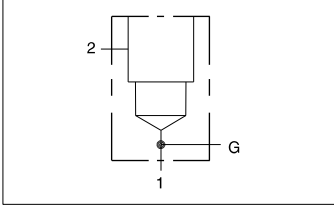

TYPICAL CARTRIDGES USED WITH THIS BODY

- RPGC - *** Page 1.06
- RPGE - *** Page 1.08
- RDFA - *** Page 1.10
- RQGB - *** Page 1.12
- RPGD - *** Page 1.14
- NQEB - *** Page 10.16

Instructions for ordering complete cartridge and body assemblies. Page v

Pressure ratings, material specifications. Page 11.02

SAE Specifications Page 11.03

.75" SAE Code 61
4-Bolt Flange Pattern
2 places.

T-3A Cavity
Locating Shoulder
Depth .06

Mounting Holes:
(opposite side)
Inch: .375-16 UNC-2B x .62 deep.
Metric: M10 x 1.50-6H x .62 deep.
2 places.

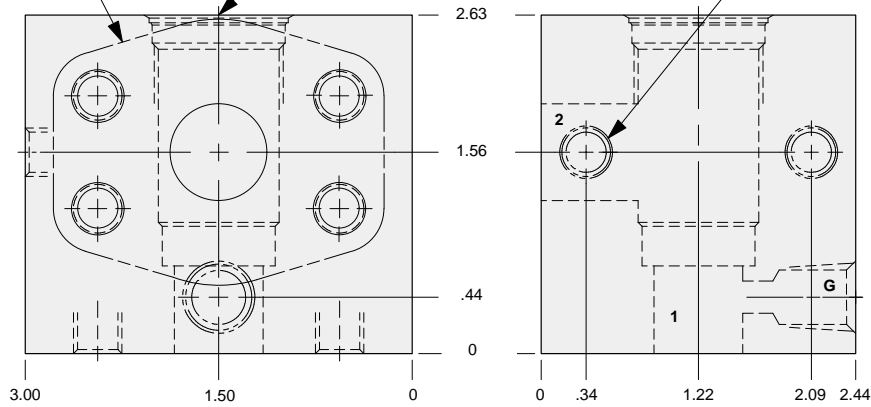

Mounting Hole Dimensions	Gage Port	ALUMINUM		DUCTILE IRON	
		Part Number	List Price	Part Number	List Price
Inch	.25 NPTF	CAO		CAO/S	
Metric	.25 BSPP	CAO/M		CAO/T	

90 degree .75" SAE Code 62 flange port body with gage port.

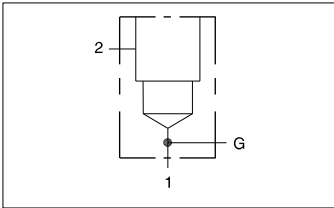

TYPICAL CARTRIDGES USED WITH THIS BODY

- RPGC - *** Page 1.06
- RPGE - *** Page 1.08
- RDFA - *** Page 1.10
- RQGB - *** Page 1.12
- RPGD - *** Page 1.14
- NQEB - *** Page 10.16

Instructions for ordering complete cartridge and body assemblies. Page v

Pressure ratings, material specifications. Page 11.02

SAE Specifications Page 11.03

.75" SAE Code 62
4-Bolt Flange Pattern
2 places.

T-3A Cavity
Locating Shoulder
Depth .06

Mounting Holes:
(opposite side)
Inch: .375-16 UNC-2B x .62 deep.
Metric: M10 x 1.50-6H x .62 deep.
2 places.

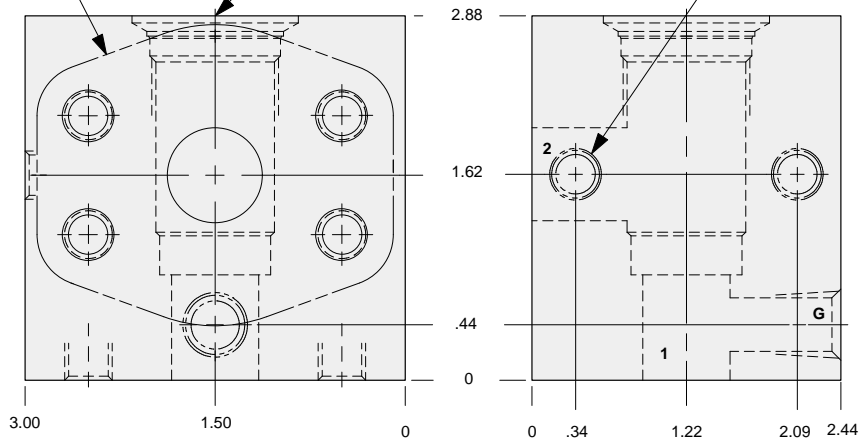

Mounting Hole Dimensions	Gage Port	ALUMINUM		DUCTILE IRON	
		Part Number	List Price	Part Number	List Price
Inch	.25 NPTF	CA3		CA3/S	
Metric	.25 BSPP	CA3/M		CA3/T	



LINE MOUNT BODIES



- Aluminum rated to 3000 psi.
- Ductile Iron rated to 5000 psi.

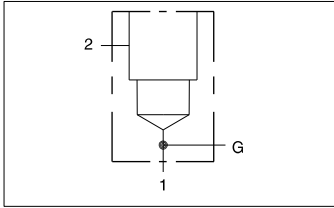

90 degree 1.00" SAE Code 61 flange port body with gage port.

1.00" SAE Code 61
4-Bolt Flange Pattern
2 places.

T-3A Cavity
Locating Shoulder
Depth .19

Mounting Holes:
(opposite side)
Inch: .375-16 UNC-2B x .62 deep.
Metric: M10 x 1.50-6H x .62 deep.
2 places.

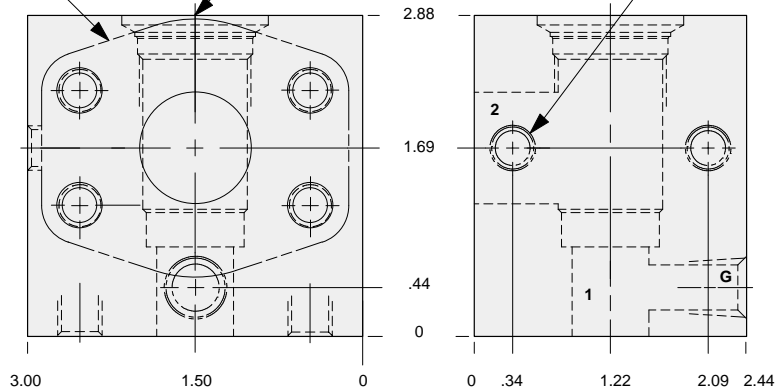

TYPICAL CARTRIDGES USED WITH THIS BODY

RPGC - ***	Page 1.06
RPGE - ***	Page 1.08
RDFA - ***	Page 1.10
RQGB - ***	Page 1.12
RPGD - ***	Page 1.14
NQEB - ***	Page 10.16

Instructions for ordering complete cartridge and body assemblies. Page v

Pressure ratings, material specifications. Page 11.02

SAE Specifications Page 11.03

Mounting Hole Dimensions	Gage Port	ALUMINUM		DUCTILE IRON	
		Part Number	List Price	Part Number	List Price
Inch	.25 NPTF	CAP		CAP/S	
Metric	.25 BSPP	CAP/M		CAP/T	

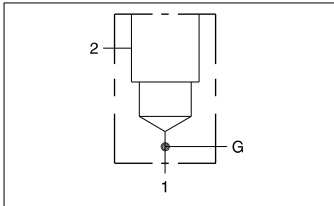

90 degree 1.00" SAE Code 62 flange port body with gage port.

1.00" SAE Code 62
4-Bolt Flange Pattern
2 places.

T-3A Cavity
Locating Shoulder
Depth .44

Mounting Holes:
(opposite side)
Inch: .375-16 UNC-2B x .62 deep.
Metric: M10 x 1.50-6H x .62 deep.
2 places.

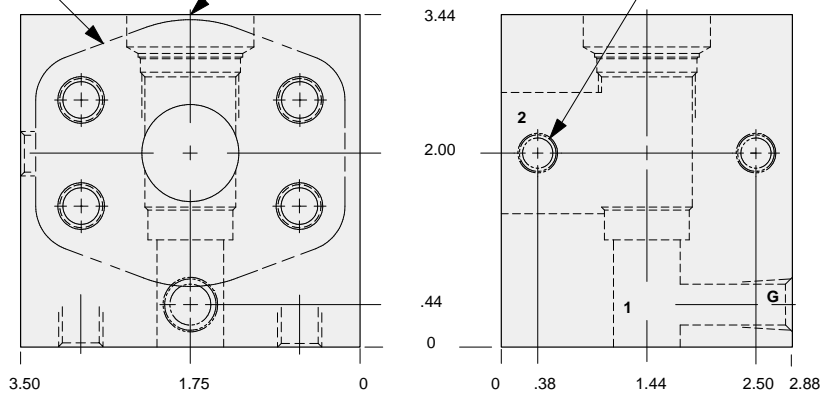

TYPICAL CARTRIDGES USED WITH THIS BODY

RPGC - ***	Page 1.06
RPGE - ***	Page 1.08
RDFA - ***	Page 1.10
RQGB - ***	Page 1.12
RPGD - ***	Page 1.14
NQEB - ***	Page 10.16

Instructions for ordering complete cartridge and body assemblies. Page v

Pressure ratings, material specifications. Page 11.02

SAE Specifications Page 11.03

Mounting Hole Dimensions	Gage Port	ALUMINUM		DUCTILE IRON	
		Part Number	List Price	Part Number	List Price
Inch	.25 NPTF	CA4		CA4/S	
Metric	.25 BSPP	CA4/M		CA4/T	



LINE MOUNT BODIES



- Aluminum rated to 3000 psi.
- Ductile Iron rated to 5000 psi.

90 degree 1.25" SAE Code 61 flange port body with gage port.

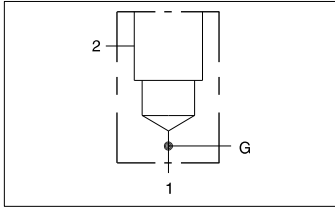

TYPICAL CARTRIDGES USED WITH THIS BODY

- RPGC - *** Page 1.06
- RPGE - *** Page 1.08
- RDFA - *** Page 1.10
- RQGB - *** Page 1.12
- RPGD - *** Page 1.14
- NQEB - *** Page 10.16

Instructions for ordering complete cartridge and body assemblies. Page v

Pressure ratings, material specifications. Page 11.02

SAE Specifications Page 11.03

1.25" SAE Code 61
4-Bolt Flange Pattern
2 places.

T-3A Cavity
Locating Shoulder
Depth .28

Mounting Holes:
(opposite side)
Inch: .375-16 UNC-2B x .62 deep.
Metric: M10 x 1.50-6H x .62 deep.
2 places.

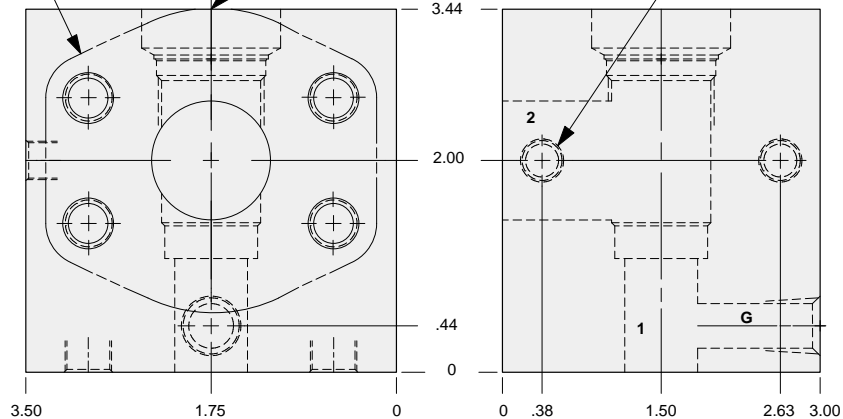

Mounting Hole Dimensions	Gage Port	ALUMINUM		DUCTILE IRON	
		Part Number	List Price	Part Number	List Price
Inch	.25 NPTF	CAQ		CAQ/S	
Metric	.25 BSPP	CAQ/M		CAQ/T	

90 degree 1.25" SAE Code 62 flange port body with gage port.

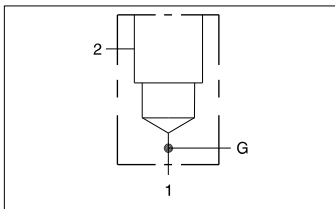

TYPICAL CARTRIDGES USED WITH THIS BODY

- RPGC - *** Page 1.06
- RPGE - *** Page 1.08
- RDFA - *** Page 1.10
- RQGB - *** Page 1.12
- RPGD - *** Page 1.14
- NQEB - *** Page 10.16

Instructions for ordering complete cartridge and body assemblies. Page v

Pressure ratings, material specifications. Page 11.02

SAE Specifications Page 11.03

1.25" SAE Code 62
4-Bolt Flange Pattern
2 places.

T-3A Cavity
Locating Shoulder
Depth .59

Mounting Holes:
(opposite side)
Inch: .375-16 UNC-2B x .62 deep.
Metric: M10 x 1.50-6H x .62 deep.
2 places.

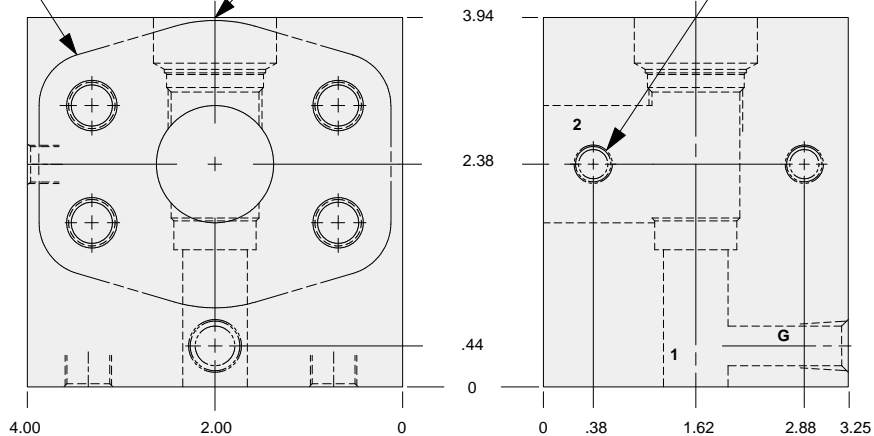

Mounting Hole Dimensions	Gage Port	ALUMINUM		DUCTILE IRON	
		Part Number	List Price	Part Number	List Price
Inch	.25 NPTF	CA5		CA5/S	
Metric	.25 BSPP	CA5/M		CA5/T	



LINE MOUNT BODIES



- Aluminum rated to 3000 psi.
- Ductile Iron rated to 5000 psi.

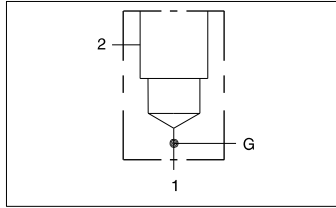

Sandwich mount through port 1.00" SAE Code 61 body with gage port.

TYPICAL CARTRIDGES USED WITH THIS BODY

RPGC - ***	Page 1.06
RPGE - ***	Page 1.08
RDFA - ***	Page 1.10
RQGB - ***	Page 1.12
RPGD - ***	Page 1.14
NQEB - ***	Page 10.16

Cartridge seal type determines O-ring type.

Instructions for ordering complete cartridge and body assemblies. Page v

Pressure ratings, material specifications. Page 11.02

SAE Specifications Page 11.03

T-3A Cavity Locating Shoulder Depth .06

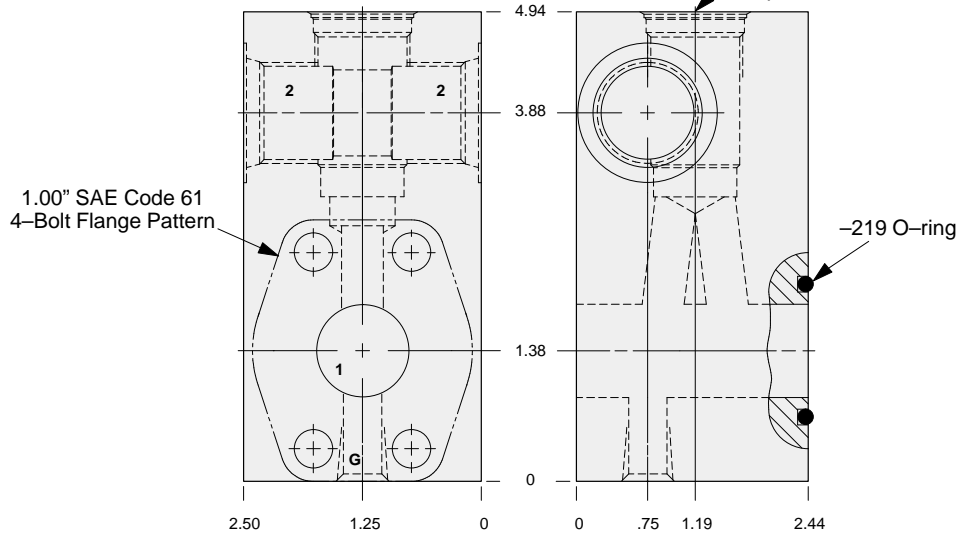

Mounting Hole Dimensions	Port 2	Gage Port	ALUMINUM		DUCTILE IRON	
			Part Number	List Price	Part Number	List Price
Inch	.75 NPTF	.25 NPTF	ZQL		ZQL/S	
Inch	SAE-12	.25 NPTF	ZQK		ZQK/S	
Metric	.75 BSPP	.25 BSPP	ZQJ/M		ZQJ/T	

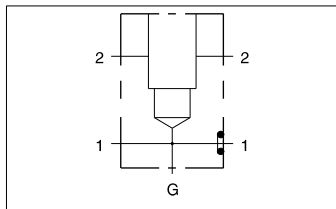

Sandwich mount through port 1.00" SAE Code 62 body with gage port.

TYPICAL CARTRIDGES USED WITH THIS BODY

RPGC - ***	Page 1.06
RPGE - ***	Page 1.08
RDFA - ***	Page 1.10
RQGB - ***	Page 1.12
RPGD - ***	Page 1.14
NQEB - ***	Page 10.16

Cartridge seal type determines O-ring type.

Instructions for ordering complete cartridge and body assemblies. Page v

Pressure ratings, material specifications. Page 11.02

SAE Specifications Page 11.03

T-3A Cavity Locating Shoulder Depth .06

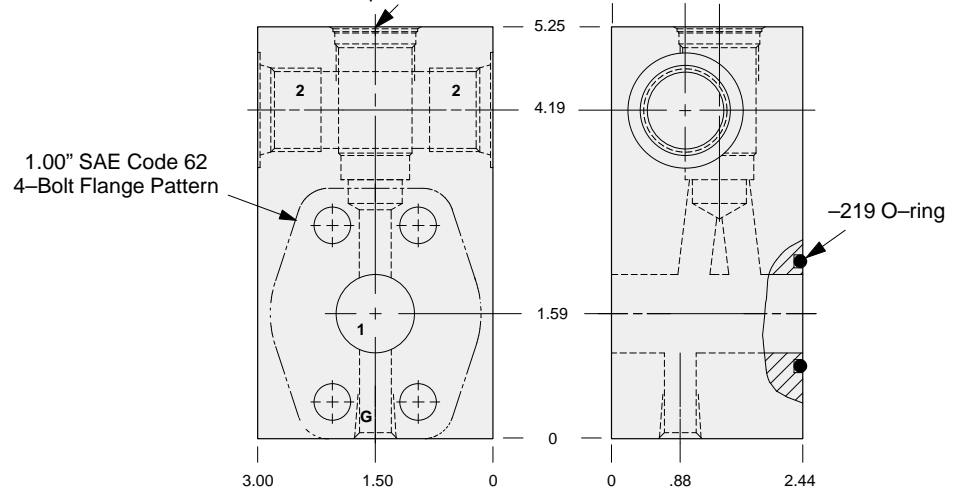

Mounting Hole Dimensions	Port 2	Gage Port	ALUMINUM		DUCTILE IRON	
			Part Number	List Price	Part Number	List Price
Inch	.75 NPTF	.25 NPTF	ZCH		ZCH/S	
Inch	SAE-12	.25 NPTF	ZCG		ZCG/S	
Metric	.75 BSPP	.25 BSPP	ZCF/M		ZCF/T	



LINE MOUNT BODIES



- Aluminum rated to 3000 psi.
- Ductile Iron rated to 5000 psi.

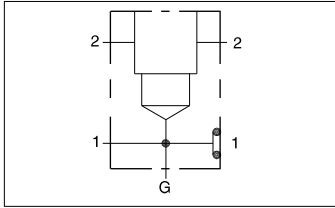

TYPICAL CARTRIDGES USED WITH THIS BODY

- RPGC - *** Page 1.06
- RPGE - *** Page 1.08
- RDFA - *** Page 1.10
- RQGB - *** Page 1.12
- RPGD - *** Page 1.14
- NQEB - *** Page 10.16

Cartridge seal type determines O-ring type.

Instructions for ordering complete cartridge and body assemblies. Page v

Pressure ratings, material specifications. Page 11.02

SAE Specifications Page 11.03

Sandwich mount through port 1.25" SAE Code 61 body with gage port.

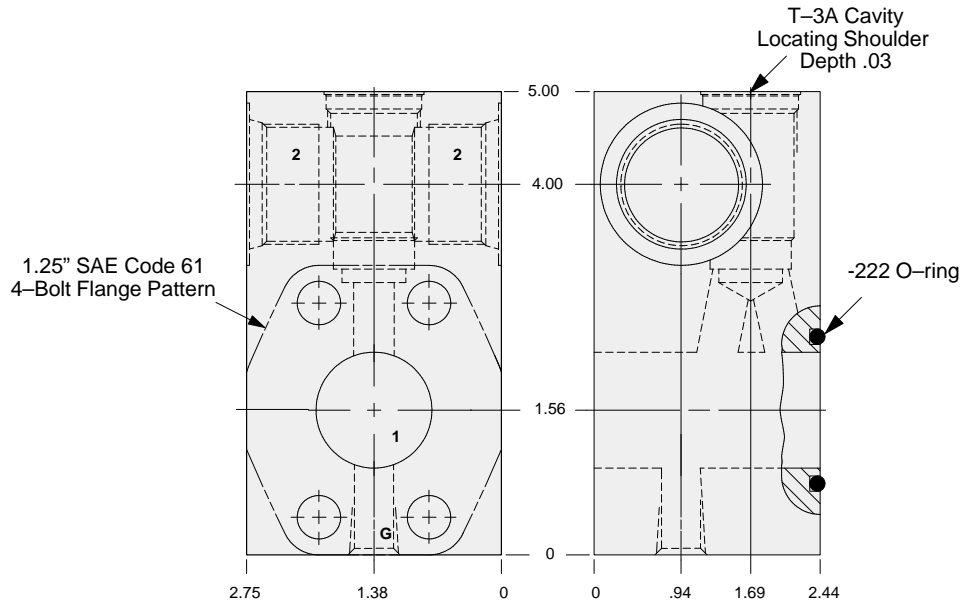

Mounting Hole Dimensions	Port 2	Gage Port	ALUMINUM		DUCTILE IRON	
			Part Number	List Price	Part Number	List Price
Inch	1.00 NPTF	.25 NPTF	ZQH		ZQH/S	
Inch	SAE-16	.25 NPTF	ZQG		ZQG/S	
Metric	1.00 BSPP	.25 BSPP	ZQF/M		ZQF/T	

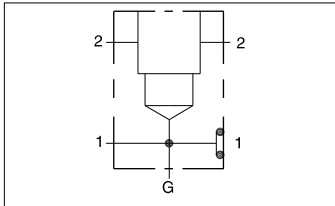

TYPICAL CARTRIDGES USED WITH THIS BODY

- RPGC - *** Page 1.06
- RPGE - *** Page 1.08
- RDFA - *** Page 1.10
- RQGB - *** Page 1.12
- RPGD - *** Page 1.14
- NQEB - *** Page 10.16

Cartridge seal type determines O-ring type.

Instructions for ordering complete cartridge and body assemblies. Page v

Pressure ratings, material specifications. Page 11.02

SAE Specifications Page 11.03

Sandwich mount through port 1.25" SAE Code 62 body with gage port.

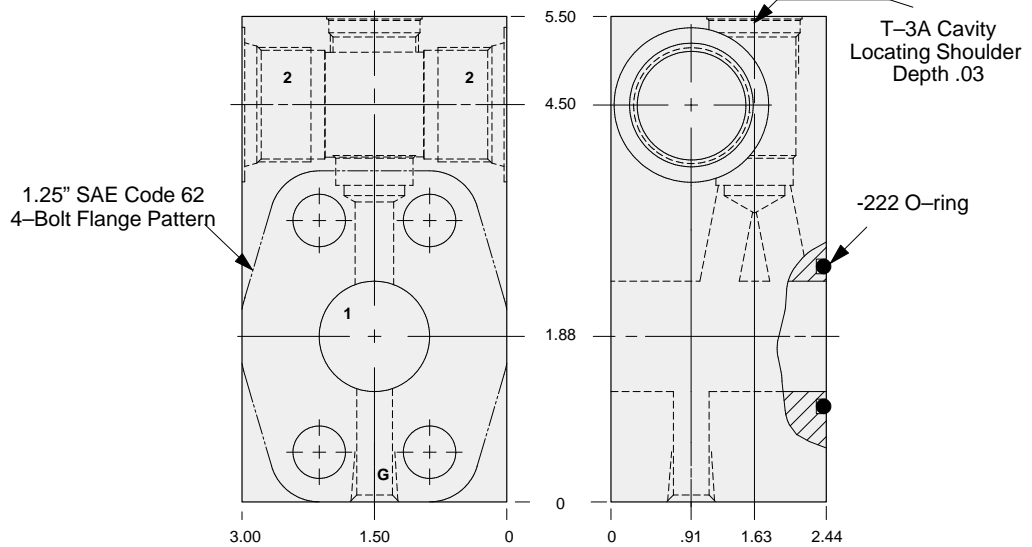

Mounting Hole Dimensions	Port 2	Gage Port	ALUMINUM		DUCTILE IRON	
			Part Number	List Price	Part Number	List Price
Inch	1.00 NPTF	.25 NPTF	ZBX		ZBX/S	
Inch	SAE-16	.25 NPTF	ZBW		ZBW/S	
Metric	1.00 BSPP	.25 BSPP	ZBV/M		ZBV/T	



LINE MOUNT BODIES



- Aluminum rated to 3000 psi.
- Ductile Iron rated to 5000 psi.

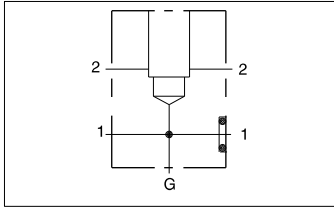

Sandwich mount through port 1.25" SAE Code 61 flange port body with gage port.

TYPICAL CARTRIDGES USED WITH THIS BODY

RPGC - ***	Page 1.06
RPGE - ***	Page 1.08
RDFA - ***	Page 1.10
RQGB - ***	Page 1.12
RPGD - ***	Page 1.14
NQEB - ***	Page 10.16

Cartridge seal type determines O-ring type.

Instructions for ordering complete cartridge and body assemblies. Page v

Pressure ratings, material specifications. Page 11.02

SAE Specifications Page 11.03

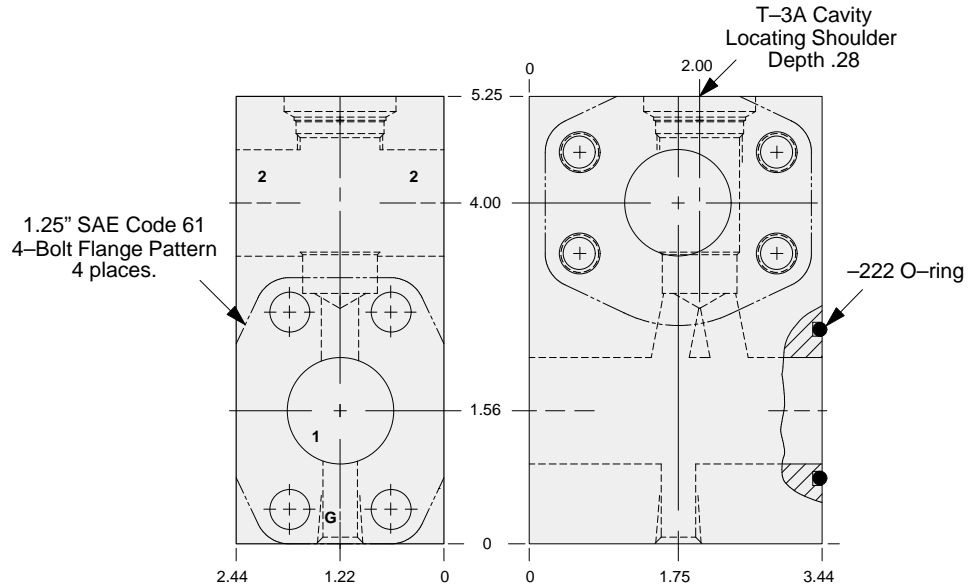

Mounting Hole Dimensions	Gage Port	ALUMINUM		DUCTILE IRON	
		Part Number	List Price	Part Number	List Price
Inch	.25 NPTF	ZQE		ZQE/S	
Metric	.25 BSPP	ZQE/M		ZQE/T	

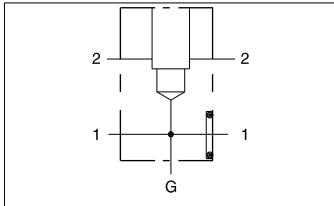

Sandwich mount through port 1.25" SAE Code 62 flange port body with gage port.

TYPICAL CARTRIDGES USED WITH THIS BODY

RPGC - ***	Page 1.06
RPGE - ***	Page 1.08
RDFA - ***	Page 1.10
RQGB - ***	Page 1.12
RPGD - ***	Page 1.14
NQEB - ***	Page 10.16

Cartridge seal type determines O-ring type.

Instructions for ordering complete cartridge and body assemblies. Page v

Pressure ratings, material specifications. Page 11.02

SAE Specifications Page 11.03

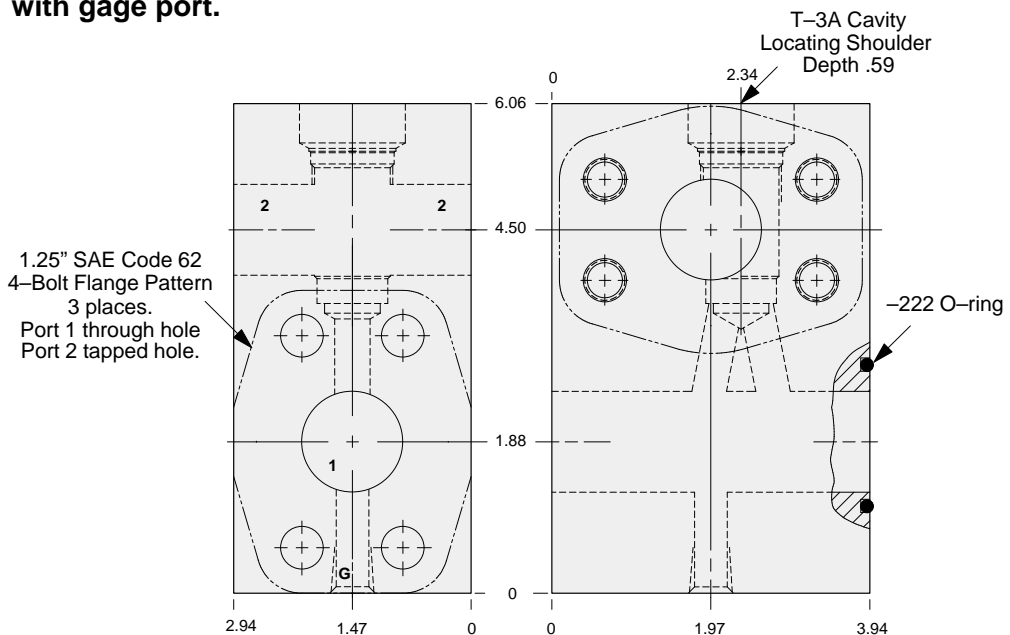

Mounting Hole Dimensions	Gage Port	ALUMINUM		DUCTILE IRON	
		Part Number	List Price	Part Number	List Price
Inch	.25 NPTF	ZDB		ZDB/S	
Metric	.25 BSPP	ZDB/M		ZDB/T	



LINE MOUNT BODIES



- Aluminum rated to 3000 psi.
- Ductile Iron rated to 5000 psi.

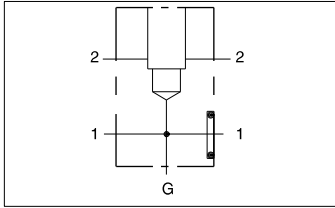

TYPICAL CARTRIDGES USED WITH THIS BODY

RPGC - ***	Page 1.06
RPGE - ***	Page 1.08
RDFA - ***	Page 1.10
RQGB - ***	Page 1.12
RPGD - ***	Page 1.14
NQEB - ***	Page 10.16

Cartridge seal type determines O-ring type.

Instructions for ordering complete cartridge and body assemblies. Page v

Pressure ratings, material specifications. Page 11.02

SAE Specifications Page 11.03

Flange mount through port 1.00" SAE Code 61 body with threaded outlet and gage port.

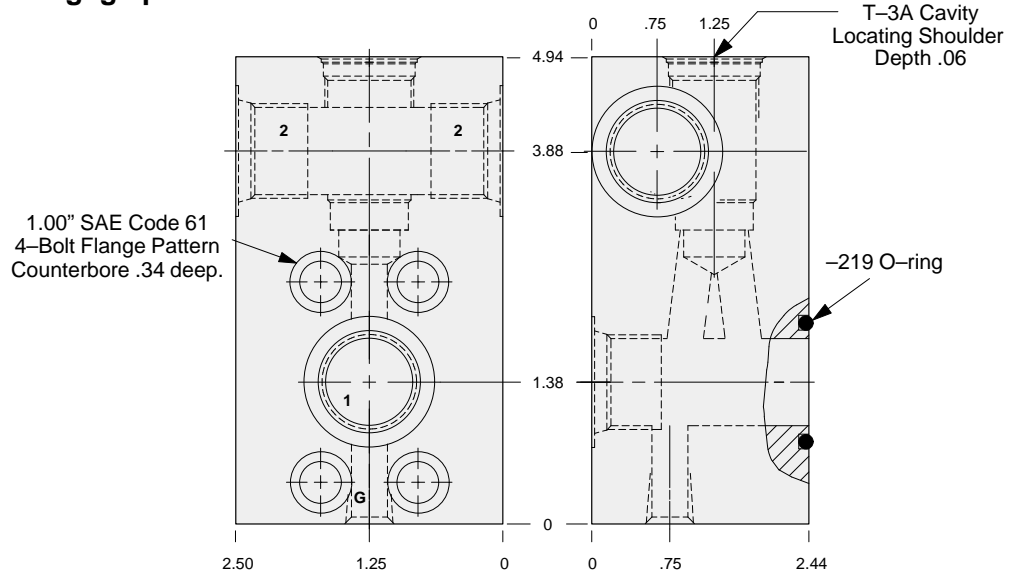

Mounting Hole Dimensions	Ports 1 & 2	Gage Port	ALUMINUM		DUCTILE IRON	
			Part Number	List Price	Part Number	List Price
Inch	.75 NPTF	.25 NPTF	ZCL		ZCL/S	
Inch	SAE-12	.25 NPTF	ZCK		ZCK/S	
Metric	.75 BSPP	.25 BSPP	ZCJ/M		ZCJ/T	

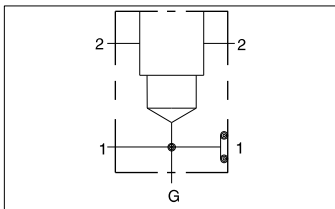

TYPICAL CARTRIDGES USED WITH THIS BODY

RPGC - ***	Page 1.06
RPGE - ***	Page 1.08
RDFA - ***	Page 1.10
RQGB - ***	Page 1.12
RPGD - ***	Page 1.14
NQEB - ***	Page 10.16

Cartridge seal type determines O-ring type.

Instructions for ordering complete cartridge and body assemblies. Page v

Pressure ratings, material specifications. Page 11.02

SAE Specifications Page 11.03

Flange mount through port 1.00" SAE Code 62 body with threaded outlet and gage port.

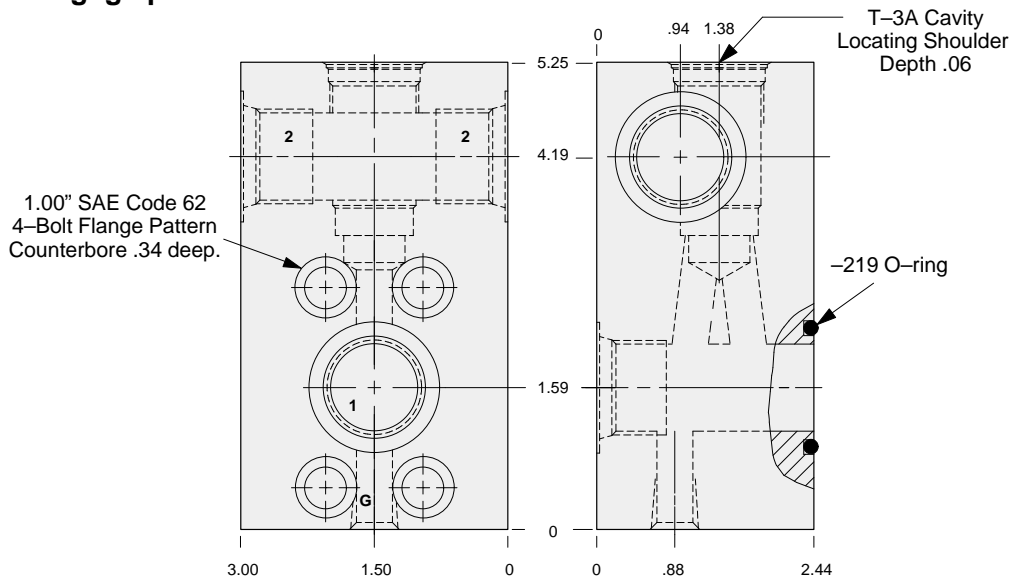

Mounting Hole Dimensions	Ports 1 & 2	Gage Port	ALUMINUM		DUCTILE IRON	
			Part Number	List Price	Part Number	List Price
Inch	.75 NPTF	.25 NPTF	ZCD		ZCD/S	
Inch	SAE-12	.25 NPTF	ZCC		ZCC/S	
Metric	.75 BSPP	.25 BSPP	ZCB/M		ZCB/T	



LINE MOUNT BODIES



- Aluminum rated to 3000 psi.
- Ductile Iron rated to 5000 psi.

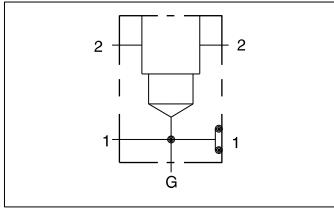

TYPICAL CARTRIDGES USED WITH THIS BODY

- RPGC - *** Page 1.06
- RPGE - *** Page 1.08
- RDFA - *** Page 1.10
- RQGB - *** Page 1.12
- RPGD - *** Page 1.14
- NQEB - *** Page 10.16

Cartridge seal type determines O-ring type.

Instructions for ordering complete cartridge and body assemblies. Page v

Pressure ratings, material specifications. Page 11.02

SAE Specifications Page 11.03

Flange mount through port 1.25" SAE Code 61 body with threaded outlet and gage port.

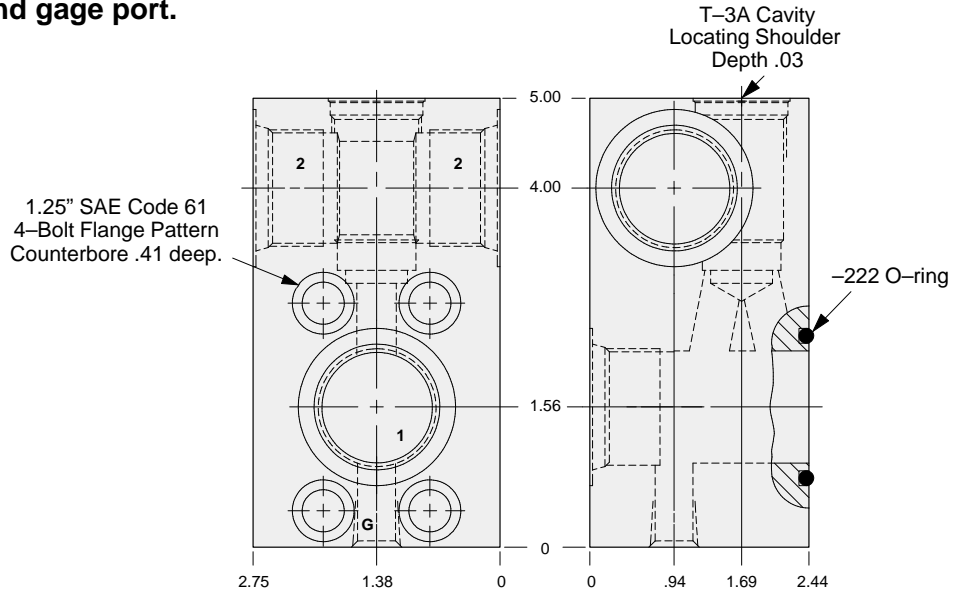

Mounting Hole Dimensions	Ports 1 & 2	Gage Port	ALUMINUM		DUCTILE IRON	
			Part Number	List Price	Part Number	List Price
Inch	1.00 NPTF	.25 NPTF	ZBZ		ZBZ/S	
Inch	SAE-16	.25 NPTF	ZKE		ZKE/S	
Metric	1.00 BSPP	.25 BSPP	ZBY/M		ZBY/T	

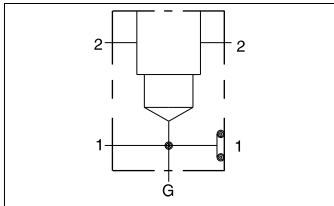

TYPICAL CARTRIDGES USED WITH THIS BODY

- RPGC - *** Page 1.06
- RPGE - *** Page 1.08
- RDFA - *** Page 1.10
- RQGB - *** Page 1.12
- RPGD - *** Page 1.14
- NQEB - *** Page 10.16

Cartridge seal type determines O-ring type.

Instructions for ordering complete cartridge and body assemblies. Page v

Pressure ratings, material specifications. Page 11.02

SAE Specifications Page 11.03

Flange mount through port 1.25" SAE Code 62 body with threaded outlet and gage port.

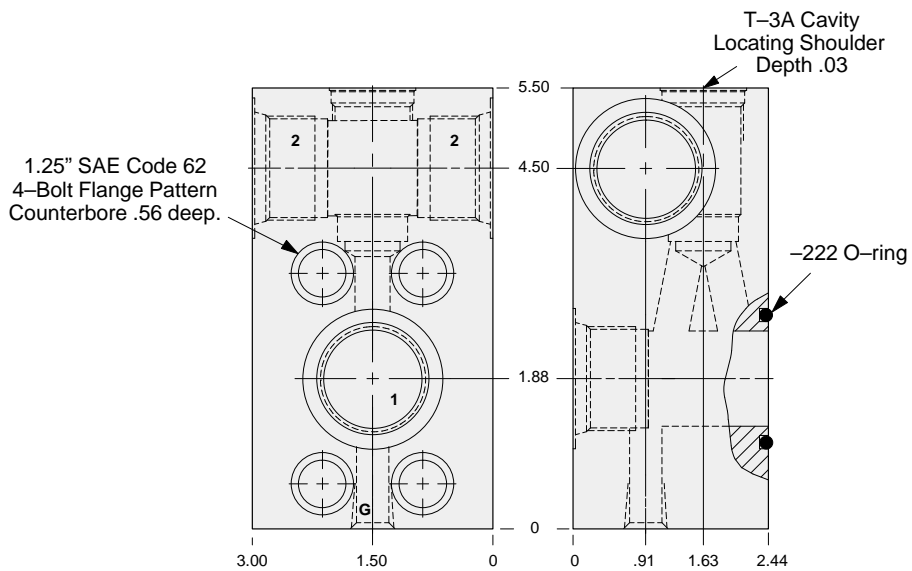

Mounting Hole Dimensions	Ports 1 & 2	Gage Port	ALUMINUM		DUCTILE IRON	
			Part Number	List Price	Part Number	List Price
Inch	1.00 NPTF	.25 NPTF	ZBT		ZBT/S	
Inch	SAE-16	.25 NPTF	ZBS		ZBS/S	
Metric	1.00 BSPP	.25 BSPP	ZBR/M		ZBR/T	



LINE MOUNT BODIES



- Aluminum rated to 3000 psi.
- Ductile Iron rated to 5000 psi.

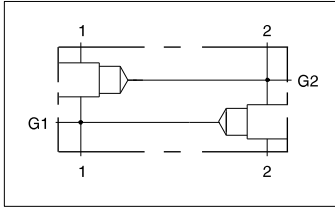

TYPICAL CARTRIDGES USED WITH THIS BODY

- RPGC - *** Page 1.06
 RPGE - *** Page 1.08
 RDFA - *** Page 1.10
 RQGB - *** Page 1.12

Instructions for ordering complete cartridge and body assemblies. Page v

Pressure ratings, material specifications. Page 11.02

Two cavity body with gage ports for cross-port relief applications.

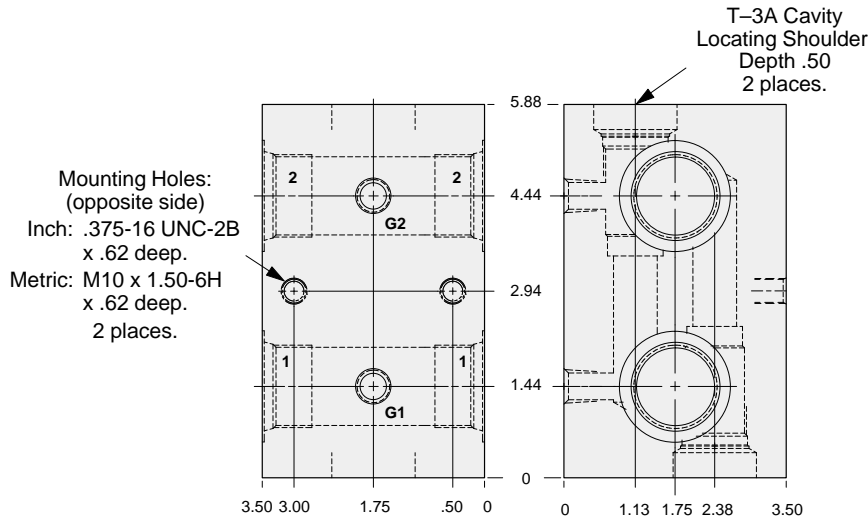

Mounting Hole Dimensions	Ports 1 & 2	Gage Ports	ALUMINUM		DUCTILE IRON	
			Part Number	List Price	Part Number	List Price
Inch	.75 NPTF	.25 NPTF	YCD		YCD/S	
Inch	1.00 NPTF	.25 NPTF	YCE		YCE/S	
Inch	SAE-12	.25 NPTF	YCL		YCL/S	
Inch	SAE-16	.25 NPTF	YCM		YCM/S	
Metric	.75 BSPP	.25 BSPP	YCW		YCW/S	
Metric	1.00 BSPP	.25 BSPP	YCX		YCX/S	

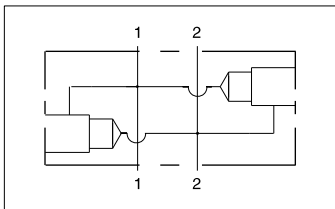

TYPICAL CARTRIDGES USED WITH THIS BODY

- RPGC - *** Page 1.06
 RPGE - *** Page 1.08
 RDFA - *** Page 1.10
 RQGB - *** Page 1.12

Instructions for ordering complete cartridge and body assemblies. Page v

Pressure ratings, material specifications. Page 11.02

Two cavity body for cross-port relief applications.

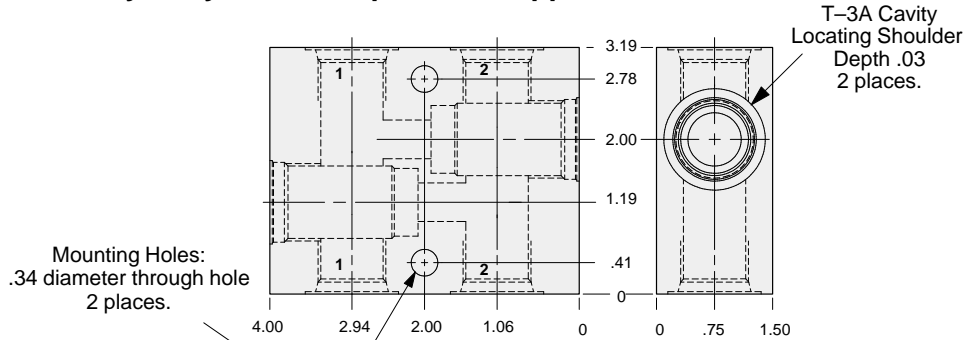

Ports 1 & 2	ALUMINUM		DUCTILE IRON	
	Part Number	List Price	Part Number	List Price
.25 NPTF	YBA		YBA/S	
.375 NPTF	YBB		YBB/S	
.50 NPTF	YBC		YBC/S	
.75 NPTF	YBD		YBD/S	
SAE-6	YBI		YBI/S	
SAE-8	YBJ		YBJ/S	
SAE-10	YBK		YBK/S	
.75 BSPP	YBO		YBO/S	
.25 BSPP	YBT		YBT/S	
.375 BSPP	YBU		YBU/S	
.50 BSPP	YBV		YBV/S	



LINE MOUNT BODIES



- Aluminum rated to 3000 psi.
- Ductile Iron rated to 5000 psi.

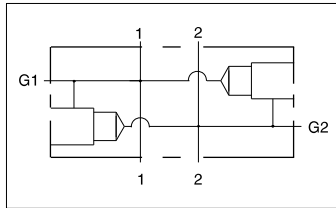

Two cavity 1.00" SAE Code 61 flange port body with gage ports for cross-port relief applications.

Mounting Holes:
(opposite side)
Inch: .375-16 UNC-2B x .62
Metric: M10 x 1.50-6H x .62
2 places.

T-3A Cavity
Locating Shoulder
Depth .50
2 places.

1.00" SAE Code 61
4-Bolt Flange
Pattern
4 places.

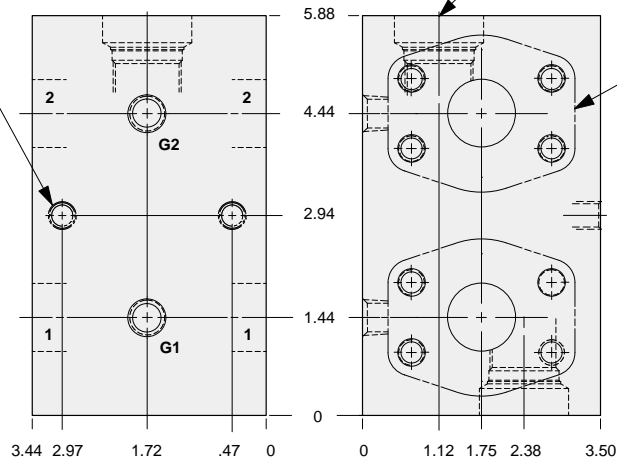

TYPICAL CARTRIDGES USED WITH THIS BODY

RPGC - ***	Page 1.06
RPGE - ***	Page 1.08
RDFA - ***	Page 1.10
RQGB - ***	Page 1.12

Instructions for ordering complete cartridge and body assemblies. Page v

Pressure ratings, material specifications. Page 11.02

SAE Specifications Page 11.03

Mounting Hole Dimensions	Gage Ports	ALUMINUM		DUCTILE IRON	
		Part Number	List Price	Part Number	List Price
Inch	.25 NPTF	YCP		YCP/S	
Metric	.25 BSPP	YCP/M		YCP/T	

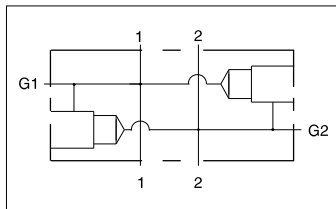

Two cavity 1.00" SAE Code 62 flange port body with gage ports for cross-port relief applications.

Mounting Holes:
(opposite side)
Inch: .375-16 UNC-2B x .62 deep.
Metric: M10 x 1.50-6H x .62 deep.
2 places.

T-3A Cavity
Locating Shoulder
Depth .40
2 places.

1.00" SAE Code 62
4-Bolt Flange
Pattern
4 places.

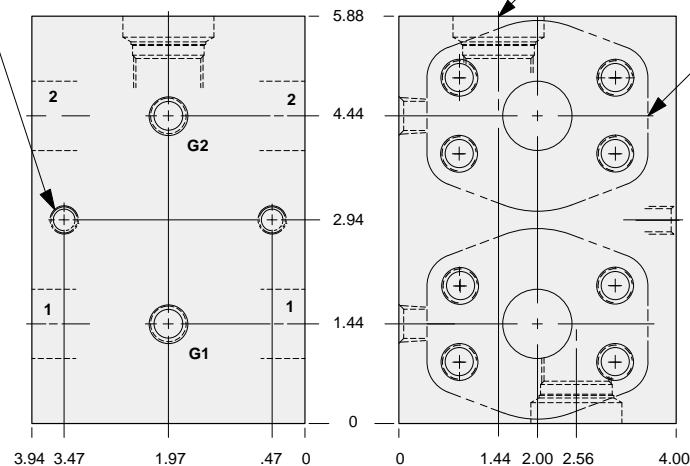

TYPICAL CARTRIDGES USED WITH THIS BODY

RPGC - ***	Page 1.06
RPGE - ***	Page 1.08
RDFA - ***	Page 1.10
RQGB - ***	Page 1.12

Instructions for ordering complete cartridge and body assemblies. Page v

Pressure ratings, material specifications. Page 11.02

SAE Specifications Page 11.03

Mounting Hole Dimensions	Gage Ports	ALUMINUM		DUCTILE IRON	
		Part Number	List Price	Part Number	List Price
Inch	.25 NPTF	YC4		YC4/S	
Metric	.25 BSPP	YC4/M		YC4/T	



LINE MOUNT BODIES



- Aluminum rated to 3000 psi.
- Ductile Iron rated to 5000 psi.

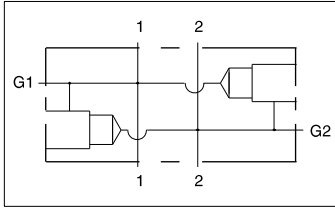

Two cavity 1.25" SAE Code 61 flange port body with gage ports for cross-port relief applications.

Mounting Holes:
(opposite side)
Inch: .375-16 UNC-2B x .62
Metric: M10 x 1.50-6H x .62
2 places.

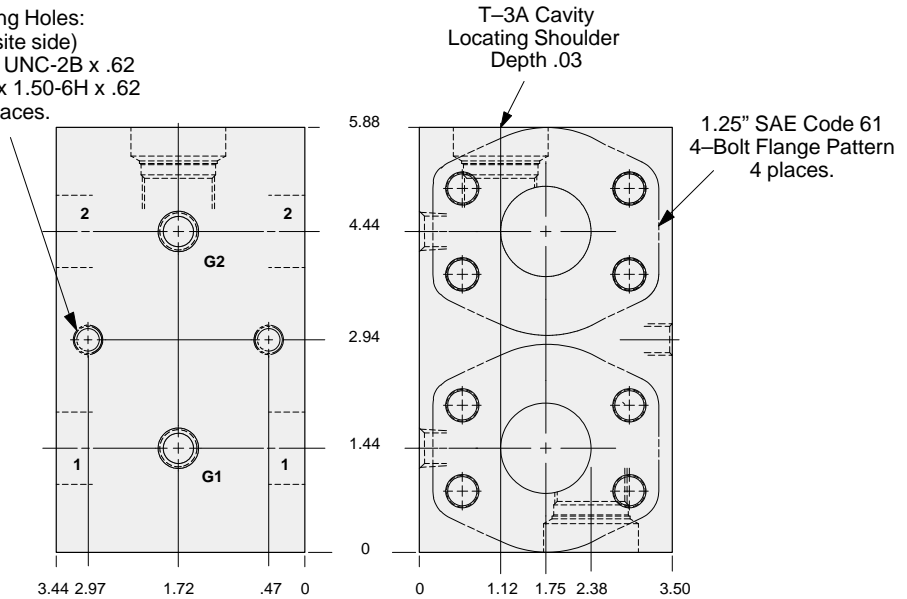

TYPICAL CARTRIDGES USED WITH THIS BODY

- RPGC - *** Page 1.06
- RPGE - *** Page 1.08
- RDFA - *** Page 1.10
- RQGB - *** Page 1.12

Instructions for ordering complete cartridge and body assemblies. Page v

Pressure ratings, material specifications. Page 11.02

SAE Specifications Page 11.03

Mounting Hole Dimensions	Gage Ports	ALUMINUM		DUCTILE IRON	
		Part Number	List Price	Part Number	List Price
Inch	.25 NPTF	YCQ		YCQ/S	
Metric	.25 BSPP	YCQ/M		YCQ/T	

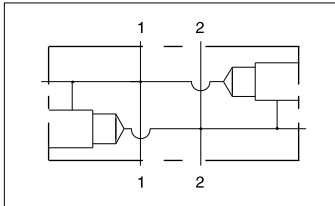

Two cavity 1.25" SAE Code 62 flange port body with gage ports for cross-port relief applications.

Mounting Holes:
(opposite side)
Inch: .375-16 UNC-2B x .62
Metric: M10 x 1.50-6H x .62
2 places.

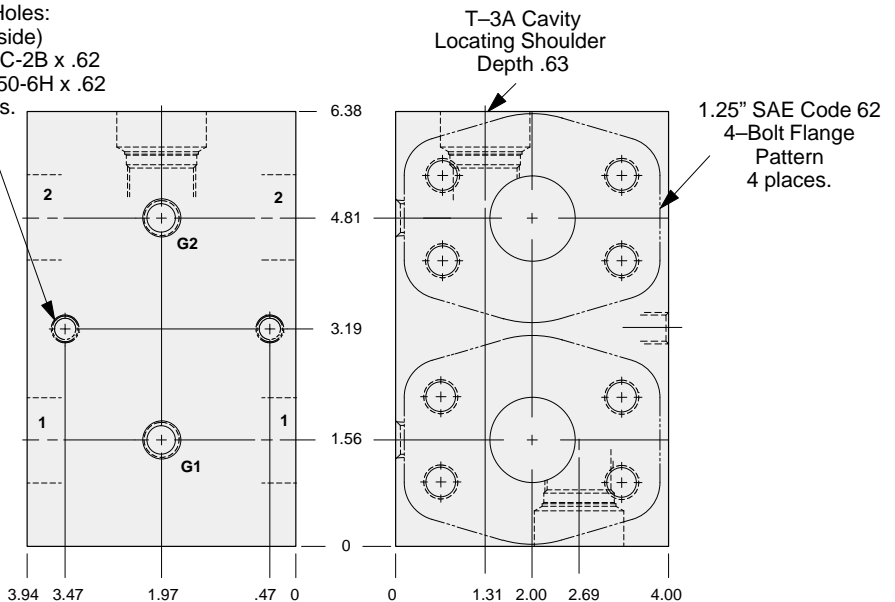

TYPICAL CARTRIDGES USED WITH THIS BODY

- RPGC - *** Page 1.06
- RPGE - *** Page 1.08
- RDFA - *** Page 1.10
- RQGB - *** Page 1.12

Instructions for ordering complete cartridge and body assemblies. Page v

Pressure ratings, material specifications. Page 11.02

SAE Specifications Page 11.03

Mounting Hole Dimensions	Gage Ports	ALUMINUM		DUCTILE IRON	
		Part Number	List Price	Part Number	List Price
Inch	.25 NPTF	YC5		YC5/S	
Metric	.25 BSPP	YC5/M		YC5/T	



LINE MOUNT BODIES



- Aluminum rated to 3000 psi.
- Ductile Iron rated to 5000 psi.

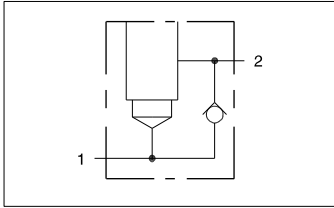

TYPICAL CARTRIDGES USED WITH THIS BODY

- RPGC - *** Page 1.06
- RPGE - *** Page 1.08
- RDFA - *** Page 1.10
- RQGB - *** Page 1.12
- RPGD - *** Page 1.14

Cartridge seal type determines check valve seal type.

Instructions for ordering complete cartridge and body assemblies. Page v

Pressure ratings, material specifications. Page 11.02

Body with reverse free flow check.

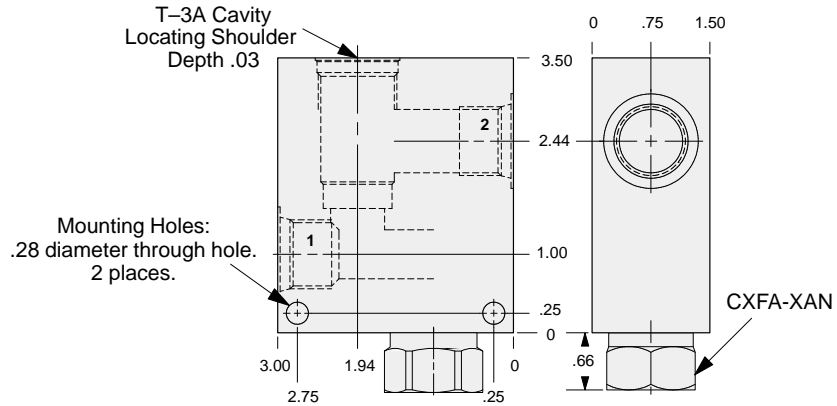

Ports 1 & 2	ALUMINUM		DUCTILE IRON	
	Part Number	List Price	Part Number	List Price
.375 NPTF	CNB		CNB/S	
.50 NPTF	CNC		CNC/S	
.75 NPTF	CND		CND/S	
SAE-6	CNI		CNI/S	
SAE-8	CNJ		CNJ/S	
SAE-10	CNK		CNK/S	
.375 BSPP	CNU		CNU/S	
.50 BSPP	CNV		CNV/S	
.75 BSPP	CNW		CNW/S	

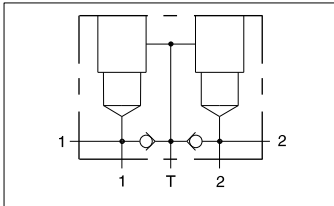

TYPICAL CARTRIDGES USED WITH THIS BODY

- RPGC - *** Page 1.06
- RPGE - *** Page 1.08
- RDFA - *** Page 1.10
- RQGB - *** Page 1.12

Cartridge seal type determines check valve seal type.

Instructions for ordering complete cartridge and body assemblies. Page v

Pressure ratings, material specifications. Page 11.02

Two cavity body with make-up checks for cross-port relief applications.

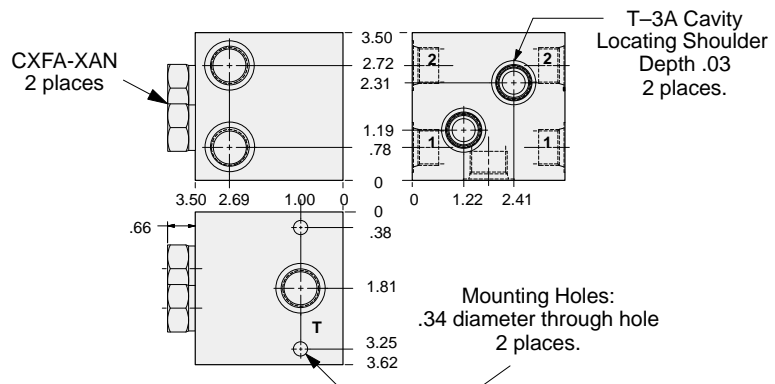

Ports 1 & 2	ALUMINUM		DUCTILE IRON	
	Part Number	List Price	Part Number	List Price
.375 NPTF	CMB		CMB/S	
.50 NPTF	CMC		CMC/S	
.75 NPTF	CMD		CMD/S	
SAE-8	CMJ		CMJ/S	
SAE-10	CMK		CMK/S	
SAE-12	CML		CML/S	
.375 BSPP	CMU		CMU/S	
.50 BSPP	CMV		CMV/S	
.75 BSPP	CMW		CMW/S	



LINE MOUNT BODIES



- Aluminum rated to 3000 psi.
- Ductile Iron rated to 5000 psi.

S2
T2A

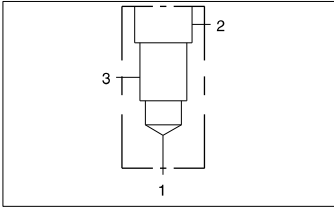

90 degree body.

Mounting Holes:
.42 diameter through hole.
2 places.

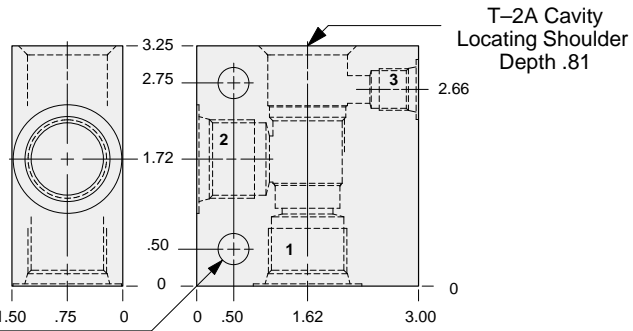

TYPICAL CARTRIDGES USED WITH THIS BODY

RVEA - ***	Page 1.18
RSFC - ***	Page 2.06
SQFB - ***	Page 2.08
RSFE - ***	Page 2.10
SCEA - ***	Page 2.12
PBFB - ***	Page 3.06
PBFC - ***	Page 3.08
CBEA - ***	Page 4.10
CBEG - ***	Page 4.12
CBEH - ***	Page 4.14
CKEB - ***	Page 4.16
LOFC - ***	Page 9.08
LKFC - ***	Page 9.10
LPFC - ***	Page 9.12
LRFC - ***	Page 9.14
COFA - ***	Page 10.12

Instructions for ordering complete cartridge and body assemblies. Page v

Pressure ratings, material specifications. Page 11.02

Ports 1 & 2	Port 3	ALUMINUM		DUCTILE IRON	
		Part Number	List Price	Part Number	List Price
.25 NPTF	.25 NPTF	BCA		BCA/S	
.375 NPTF	.25 NPTF	BCB		BCB/S	
.50 NPTF	.25 NPTF	BCC		BCC/S	
.75 NPTF	.25 NPTF	BCD		BCD/S	
SAE-6	SAE-6	BCI		BCI/S	
SAE-8	SAE-6	BCJ		BCJ/S	
SAE-10	SAE-6	BCK		BCK/S	
SAE-12	SAE-6	BCL		BCL/S	
.25 BSPP	.25 BSPP	BCT		BCT/S	
.375 BSPP	.25 BSPP	BCU		BCU/S	
.50 BSPP	.25 BSPP	BCV		BCV/S	
.75 BSPP	.25 BSPP	BCW		BCW/S	

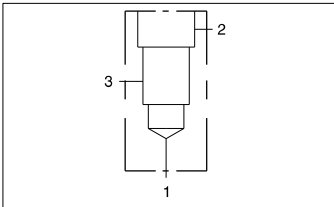

90 degree body with high capacity port 3.

Mounting Holes:
.42 diameter through hole.
2 places.

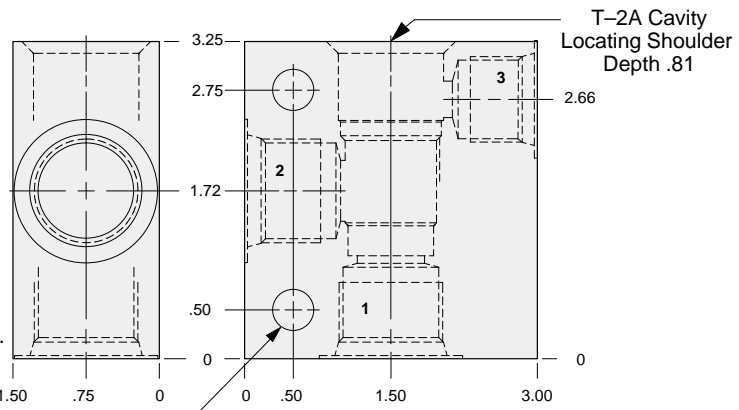

TYPICAL CARTRIDGES USED WITH THIS BODY

PPFB - ***	Page 3.10
PPFC - ***	Page 3.12
DPCA - ***	Page 6.02
DPCB - ***	Page 8.06
DPCC - ***	Page 8.07
DPCD - ***	Page 8.08
FRDA - ***	Page 8.09

Instructions for ordering complete cartridge and body assemblies. Page v

Pressure ratings, material specifications. Page 11.02

Ports 1 & 2	Port 3	ALUMINUM		DUCTILE IRON	
		Part Number	List Price	Part Number	List Price
.375 NPTF	.375 NPTF	BAB		BAB/S	
.50 NPTF	.50 NPTF	BAC		BAC/S	
.75 NPTF	.50 NPTF	BAD		BAD/S	
SAE-8	SAE-8	BAJ		BAJ/S	
SAE-10	SAE-10	BAK		BAK/S	
SAE-12	SAE-10	BAL		BAL/S	
.375 BSPP	.375 BSPP	BAU		BAU/S	
.50 BSPP	.50 BSPP	BAV		BAV/S	
.75 BSPP	.50 BSPP	BAW		BAW/S	



LINE MOUNT BODIES



- Aluminum rated to 3000 psi.
- Ductile Iron rated to 5000 psi.

S2
T2A

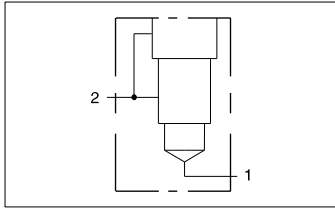

Body with port 3 connected to port 2.

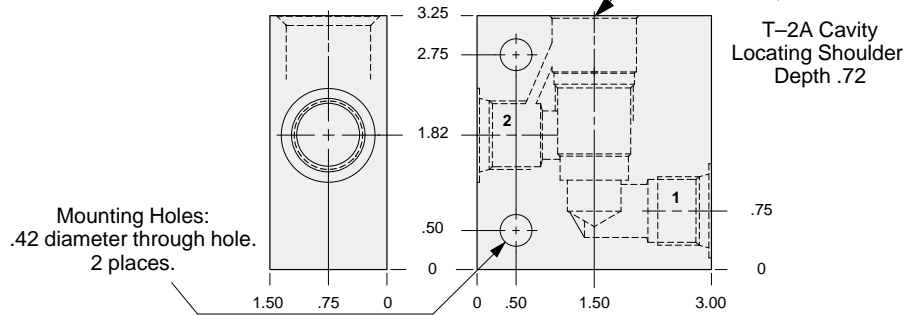

TYPICAL CARTRIDGES USED WITH THIS BODY

- CBEA - *** Page 4.10
CBEG - *** Page 4.12
CBEH - *** Page 4.14

Instructions for ordering complete cartridge and body assemblies. Page v

Pressure ratings, material specifications. Page 11.02

All Ports	ALUMINUM		DUCTILE IRON	
	Part Number	List Price	Part Number	List Price
.25 NPTF	BDA		BDA/S	
.375 NPTF	BDB		BDB/S	
.50 NPTF	BDC		BDC/S	
.75 NPTF	BDD		BDD/S	
SAE-6	BDI		BDI/S	
SAE-8	BDJ		BDJ/S	
SAE-10	BDK		BDK/S	
.25 BSPP	BDT		BDT/S	
.375 BSPP	BDU		BDU/S	
.50 BSPP	BDV		BDV/S	
.75 BSPP	BDW		BDW/S	



LINE MOUNT BODIES



- Aluminum rated to 3000 psi.
- Ductile Iron rated to 5000 psi.

S2
T2A

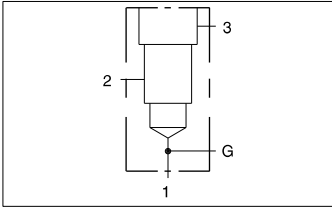

90 degree body with gage port.

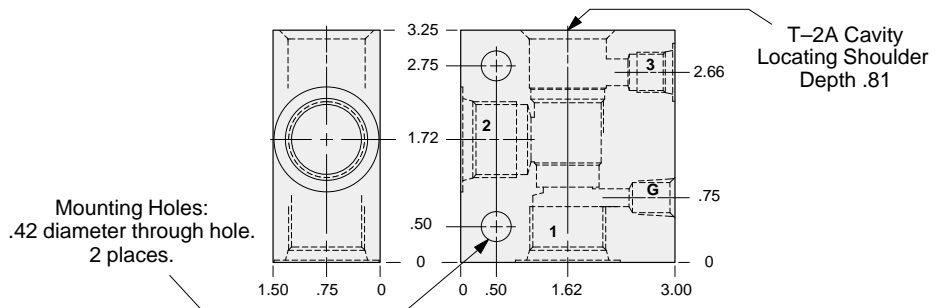

TYPICAL CARTRIDGES USED WITH THIS BODY

RVEA - ***	Page 1.18
RSFC - ***	Page 2.06
SQFB - ***	Page 2.08
RSFE - ***	Page 2.10
SCEA - ***	Page 2.12
PBFB - ***	Page 3.06
PBFC - ***	Page 3.08
LOFC - ***	Page 9.08
LKFC - ***	Page 9.10
LPFC - ***	Page 9.12
LRFC - ***	Page 9.14
COFA - ***	Page 10.12

Instructions for ordering complete cartridge and body assemblies. Page v

Pressure ratings, material specifications. Page 11.02

Ports 1 & 2	Port 3	Gage Port	ALUMINUM		DUCTILE IRON	
			Part Number	List Price	Part Number	List Price
.25 NPTF	.25 NPTF	.25 NPTF	BFA		BFA/S	
.375 NPTF	.25 NPTF	.25 NPTF	BFB		BFB/S	
.50 NPTF	.25 NPTF	.25 NPTF	BFC		BFC/S	
.75 NPTF	.25 NPTF	.25 NPTF	BFD		BFD/S	
SAE-6	SAE-6	.25 NPTF	BFI		BFI/S	
SAE-8	SAE-6	.25 NPTF	BFJ		BFJ/S	
SAE-10	SAE-6	.25 NPTF	BFK		BFK/S	
SAE-12	SAE-6	.25 NPTF	BFL		BFL/S	
.25 BSPP	.25 BSPP	.25 BSPP	BFT		BFT/S	
.375 BSPP	.25 BSPP	.25 BSPP	BFU		BFU/S	
.50 BSPP	.25 BSPP	.25 BSPP	BFV		BFV/S	
.75 BSPP	.25 BSPP	.25 BSPP	BFW		BFW/S	

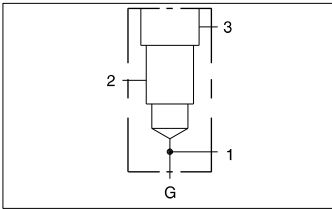

90 degree body with high capacity port 3 and gage port.

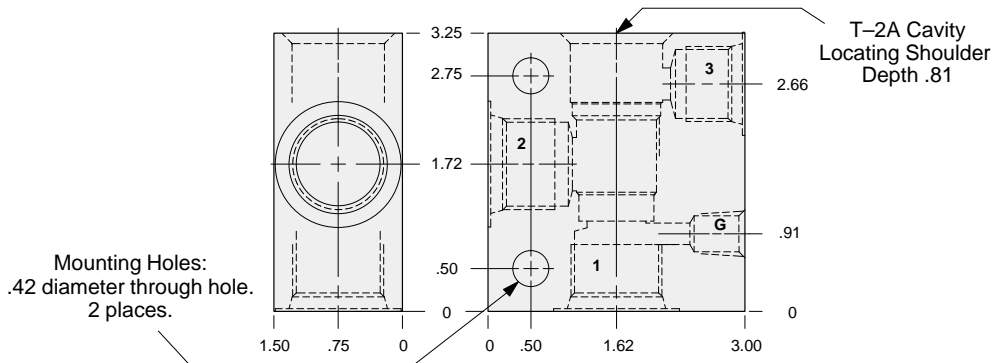

TYPICAL CARTRIDGES USED WITH THIS BODY

PPFB - ***	Page 3.10
PPFC - ***	Page 3.12
DPCA - ***	Page 8.06
DPCB - ***	Page 8.07
DPCD - ***	Page 8.08
DPCD - ***	Page 8.09

Instructions for ordering complete cartridge and body assemblies. Page v

Pressure ratings, material specifications. Page 11.02

Ports 1 & 2	Port 3	Gage Port	ALUMINUM		DUCTILE IRON	
			Part Number	List Price	Part Number	List Price
.375 NPTF	.375 NPTF	.25 NPTF	BLB		BLB/S	
.50 NPTF	.50 NPTF	.25 NPTF	BLC		BLC/S	
.75 NPTF	.50 NPTF	.25 NPTF	BLD		BLD/S	
SAE-6	SAE-6	.25 NPTF	BLI		BLI/S	
SAE-8	SAE-8	.25 NPTF	BLJ		BLJ/S	
SAE-10	SAE-10	.25 NPTF	BLK		BLK/S	
SAE-12	SAE-10	.25 NPTF	BLL		BLL/S	
.375 BSPP	.375 BSPP	.25 BSPP	BLU		BLU/S	
.50 BSPP	.50 BSPP	.25 BSPP	BLV		BLV/S	
.75 BSPP	.50 BSPP	.25 BSPP	BLW		BLW/S	



LINE MOUNT BODIES



- Aluminum rated to 3000 psi.
- Ductile Iron rated to 5000 psi.

S2
T2A

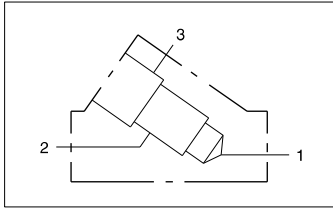

Inline body.

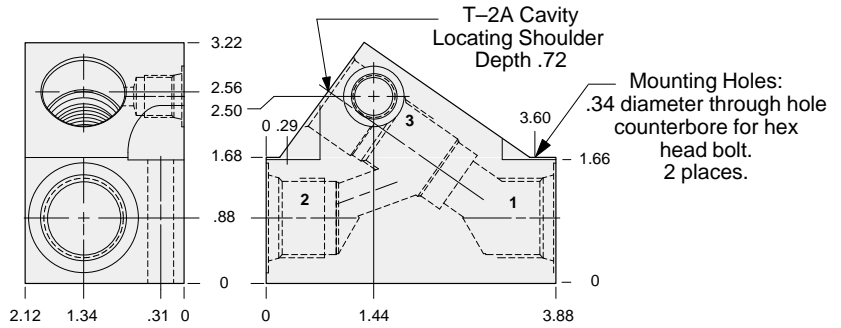

TYPICAL CARTRIDGES USED WITH THIS BODY

RVEA - ***	Page 1.18
RSFC - ***	Page 2.06
SQFB - ***	Page 2.08
RSFE - ***	Page 2.10
SCEA - ***	Page 2.12
PBFB - ***	Page 3.06
PBFC - ***	Page 3.08
CBEA - ***	Page 4.10
CBEG - ***	Page 4.12
CBEH - ***	Page 4.14
CKEB - ***	Page 4.16
LOFC - ***	Page 9.08
LKFC - ***	Page 9.10
LPFC - ***	Page 9.12
LRFC - ***	Page 9.14
COFA - ***	Page 10.12

Instructions for ordering complete cartridge and body assemblies. Page v

Pressure ratings, material specifications. Page 11.02

Ports 1 & 2	Port 3	ALUMINUM		DUCTILE IRON	
		Part Number	List Price	Part Number	List Price
.25 NPTF	.25 NPTF	BVA		BVA/S	
.375 NPTF	.25 NPTF	BVB		BVB/S	
.50 NPTF	.25 NPTF	BVC		BVC/S	
.75 NPTF	.25 NPTF	BVD		BVD/S	
SAE-6	SAE-6	BVI		BVI/S	
SAE-8	SAE-6	BVJ		BVJ/S	
SAE-10	SAE-6	BVK		BVK/S	
SAE-12	SAE-6	BVL		BVL/S	
.25 BSPP	.25 BSPP	BVT		BVT/S	
.375 BSPP	.25 BSPP	BVU		BVU/S	
.50 BSPP	.25 BSPP	BVV		BVV/S	
.75 BSPP	.25 BSPP	BVW		BVW/S	

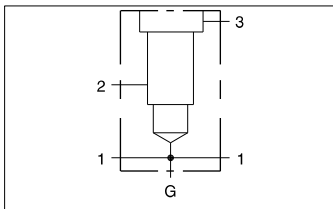

Through port body with gage port.

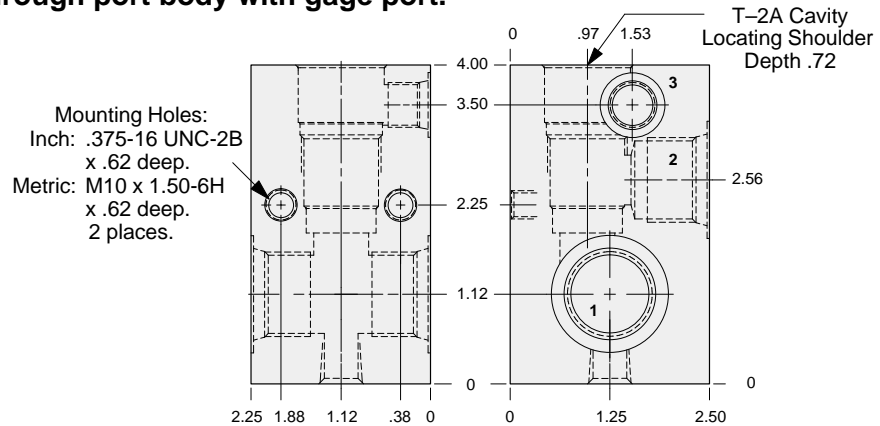

TYPICAL CARTRIDGES USED WITH THIS BODY

RVEA - ***	Page 1.18
RSFC - ***	Page 2.06
SQFB - ***	Page 2.08
RSFE - ***	Page 2.10
SCEA - ***	Page 2.12
PBFB - ***	Page 3.06
PBFC - ***	Page 3.08

Instructions for ordering complete cartridge and body assemblies. Page v

Pressure ratings, material specifications. Page 11.02

Mounting Hole Dimensions	Ports 1 & 2	Port 3	Gage Port	ALUMINUM		DUCTILE IRON	
				Part Number	List Price	Part Number	List Price
Inch	.375 NPTF	.25 NPTF	.25 NPTF	BHB		BHB/S	
Inch	.50 NPTF	.25 NPTF	.25 NPTF	BHC		BHC/S	
Inch	.75 NPTF	.25 NPTF	.25 NPTF	BHD		BHD/S	
Inch	SAE-8	SAE-6	.25 NPTF	BHJ		BHJ/S	
Inch	SAE-10	SAE-6	.25 NPTF	BHK		BHK/S	
Inch	SAE-12	SAE-6	.25 NPTF	BHL		BHL/S	
Metric	.375 BSPP	.25 BSPP	.25 BSPP	BHU		BHU/S	
Metric	.50 BSPP	.25 BSPP	.25 BSPP	BHV		BHV/S	
Metric	.75 BSPP	.25 BSPP	.25 BSPP	BHW		BHW/S	



LINE MOUNT BODIES



- Aluminum rated to 3000 psi.
- Ductile Iron rated to 5000 psi.

S2
T2A

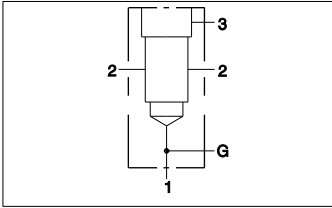

TYPICAL CARTRIDGES USED WITH THIS BODY

PBFB - *** Page 3.06
 PBFC - *** Page 3.08

Instructions for ordering complete cartridge and body assemblies. Page v

Pressure ratings, material specifications. Page 11.02

Through port body with gage port.

Mounting Holes:
 (opposite side)
 Inch: .375-16 UNC-2B
 x .62 deep.
 Metric: M10 x 1.50-6H
 x .62 deep.
 2 places.

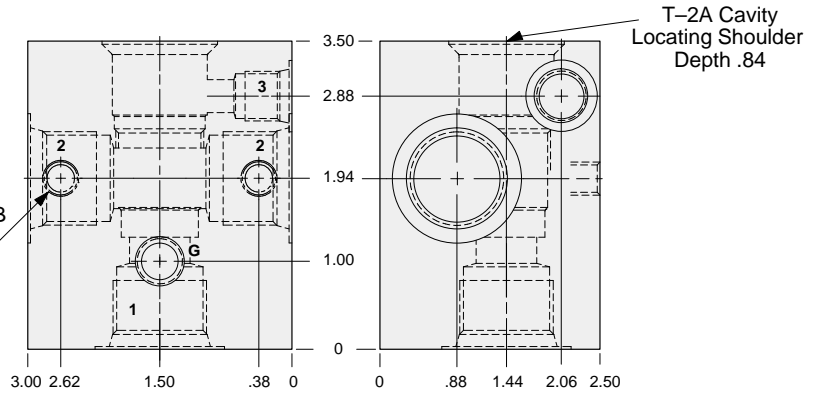

Mounting Hole Dimensions	Ports 1 & 2	Port 3	Gage Port	ALUMINUM		DUCTILE IRON	
				Part Number	List Price	Part Number	List Price
Inch	.375 NPTF	.25 NPTF	.25 NPTF	WSE		WSE/S	
Inch	.50 NPTF	.25 NPTF	.25 NPTF	WSF		WSF/S	
Inch	.75 NPTF	.25 NPTF	.25 NPTF	WSG		WSG/S	
Inch	SAE-8	SAE-6	.25 NPTF	WSH		WSH/S	
Inch	SAE-10	SAE-6	.25 NPTF	WSI		WSI/S	
Inch	SAE-12	SAE-6	.25 NPTF	WSJ		WSJ/S	
Metric	.375 BSPP	.25 BSPP	.25 BSPP	WSK		WSK/S	
Metric	.50 BSPP	.25 BSPP	.25 BSPP	WSL		WSL/S	
Metric	.75 BSPP	.25 BSPP	.25 BSPP	WSM		WSM/S	

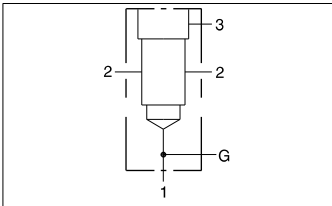

TYPICAL CARTRIDGES USED WITH THIS BODY

PPFB - *** Page 3.10
 PPFC - *** Page 3.12
 DPCA - *** Page 8.06
 DPCB - *** Page 8.07
 DPCC - *** Page 8.08
 DPCD - *** Page 8.09

Instructions for ordering complete cartridge and body assemblies. Page v

Pressure ratings, material specifications. Page 11.02

Through port body with high capacity port 3 and gage port.

Mounting Holes:
 (opposite side)
 Inch: .375-16 UNC-2B
 x .62 deep.
 Metric: M10 x 1.50-6H
 x .62 deep.
 2 places.

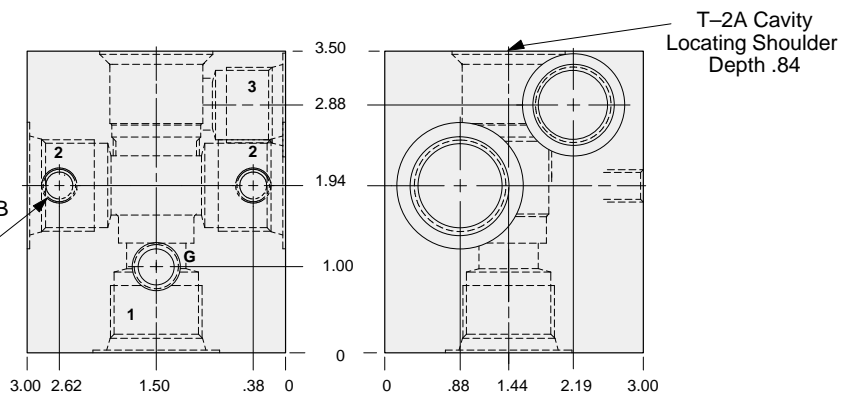

Mounting Hole Dimensions	Ports 1 & 2	Port 3	Gage Port	ALUMINUM		DUCTILE IRON	
				Part Number	List Price	Part Number	List Price
Inch	.375 NPTF	.375 NPTF	.25 NPTF	WSN		WSN/S	
Inch	.50 NPTF	.50 NPTF	.25 NPTF	WSO		WSO/S	
Inch	.75 NPTF	.50 NPTF	.25 NPTF	WSP		WSP/S	
Inch	SAE-8	SAE-8	.25 NPTF	WSQ		WSQ/S	
Inch	SAE-10	SAE-10	.25 NPTF	WSR		WSR/S	
Inch	SAE-12	SAE-10	.25 NPTF	WSS		WSS/S	
Metric	.375 BSPP	.375 BSPP	.25 BSPP	WST		WST/S	
Metric	.50 BSPP	.50 BSPP	.25 BSPP	WSU		WSU/S	
Metric	.75 BSPP	.50 BSPP	.25 BSPP	WSV		WSV/S	



LINE MOUNT BODIES



- Aluminum rated to 3000 psi.
- Ductile Iron rated to 5000 psi.

S2
T2A

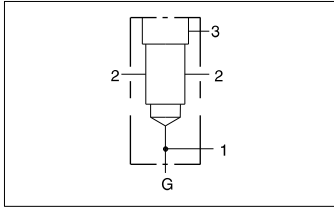

Sandwich mount through port 1.00" SAE Code 61 body with gage port.

TYPICAL CARTRIDGES USED WITH THIS BODY

- RVEA - *** Page 1.18
- RSFC - *** Page 2.06
- SQFB - *** Page 2.08
- RSFE - *** Page 2.10
- SCEA - *** Page 2.12

Cartridge seal type determines O-ring type.

Instructions for ordering complete cartridge and body assemblies. Page v

Pressure ratings, material specifications. Page 11.02

SAE Specifications Page 11.03

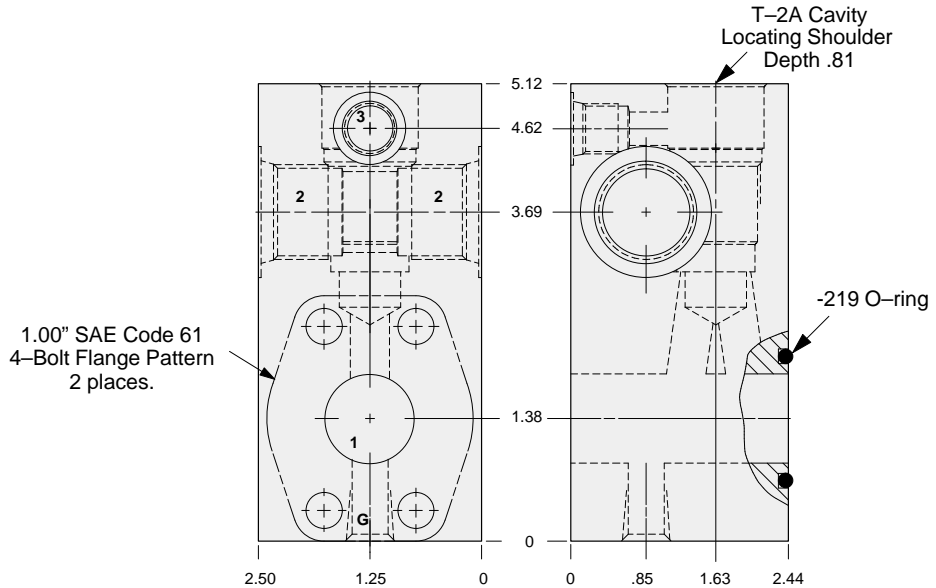

Mounting Hole Dimensions	Port 2	Port 3	Gage Port	ALUMINUM		DUCTILE IRON	
				Part Number	List Price	Part Number	List Price
Inch	.75 NPTF	.25 NPTF	.25 NPTF	ZMN		ZMN/S	
Inch	SAE-12	SAE-6	.25 NPTF	ZMP		ZMP/S	
Metric	.75 BSPP	.25 BSPP	.25 BSPP	ZMR/M		ZMR/T	

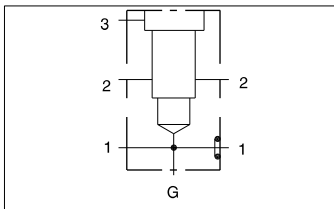

Sandwich mount through port 1.00" SAE Code 62 body with gage port.

TYPICAL CARTRIDGES USED WITH THIS BODY

- RVEA - *** Page 1.18
- RSFC - *** Page 2.06
- SQFB - *** Page 2.08
- RSFE - *** Page 2.10
- SCEA - *** Page 2.12

Cartridge seal type determines O-ring type.

Instructions for ordering complete cartridge and body assemblies. Page v

Pressure ratings, material specifications. Page 11.02

SAE Specifications Page 11.03

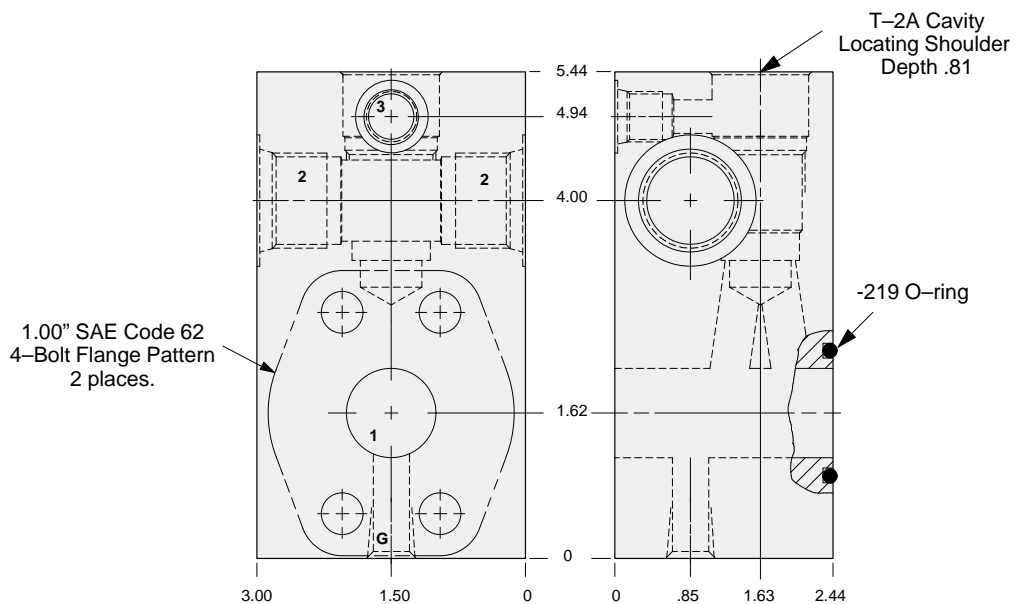

Mounting Hole Dimensions	Port 2	Port 3	Gage Port	ALUMINUM		DUCTILE IRON	
				Part Number	List Price	Part Number	List Price
Inch	SAE-12	SAE-6	.25 NPTF	WYG		WYG/S	
Inch	.75 NPTF	.25 NPTF	.25 NPTF	WYH		WYH/S	
Metric	.75 BSPP	.25 BSPP	.25 BSPP	WYF/M		WYF/T	



LINE MOUNT BODIES



- Aluminum rated to 3000 psi.
- Ductile Iron rated to 5000 psi.

S2
T2A

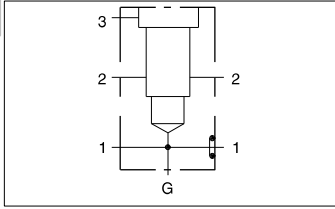

Flange mount through port 1.00" SAE Code 61 body with threaded outlet and gage port.

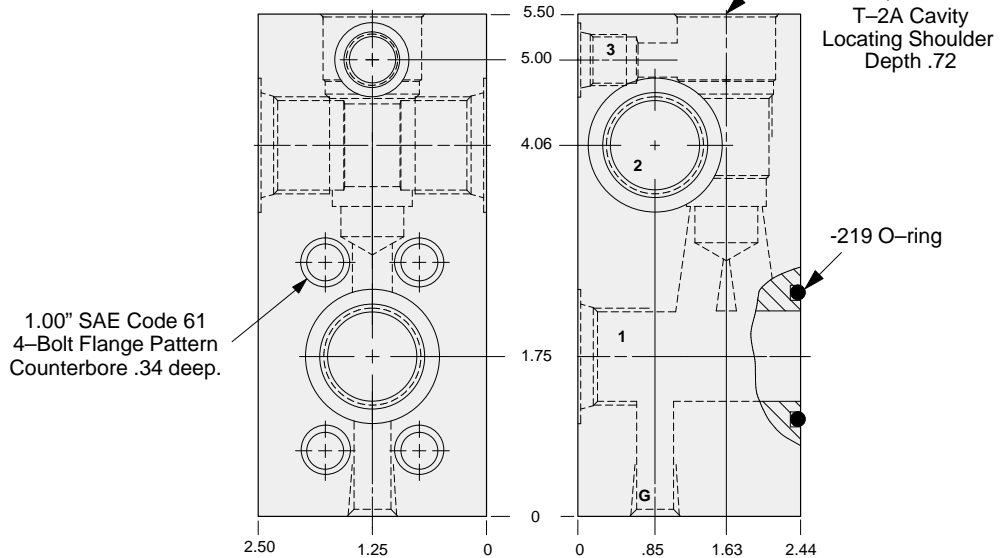

TYPICAL CARTRIDGES USED WITH THIS BODY

RVEA - ***	Page 1.18
RSFC - ***	Page 2.06
SQFB - ***	Page 2.08
RSFE - ***	Page 2.10
SCEA - ***	Page 2.12

Cartridge seal type determines O-ring type.

Instructions for ordering complete cartridge and body assemblies. Page v

Pressure ratings, material specifications. Page 11.02

SAE Specifications Page 11.03

Mounting Hole Dimensions	Ports 1 & 2	Port 3	Gage Port	ALUMINUM		DUCTILE IRON	
				Part Number	List Price	Part Number	List Price
Inch	.75 NPTF	.25 NPTF	.25 NPTF	WYW		WYW/S	
Inch	SAE-12	SAE-6	.25 NPTF	WYV		WYV/S	
Metric	.75 BSPP	.25 BSPP	.25 BSPP	WYU/M		WYU/T	

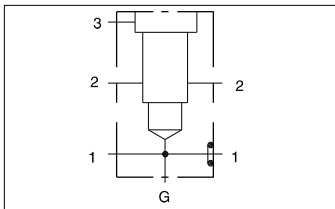

Flange mount through port 1.00" SAE Code 62 body with threaded outlet and gage port.

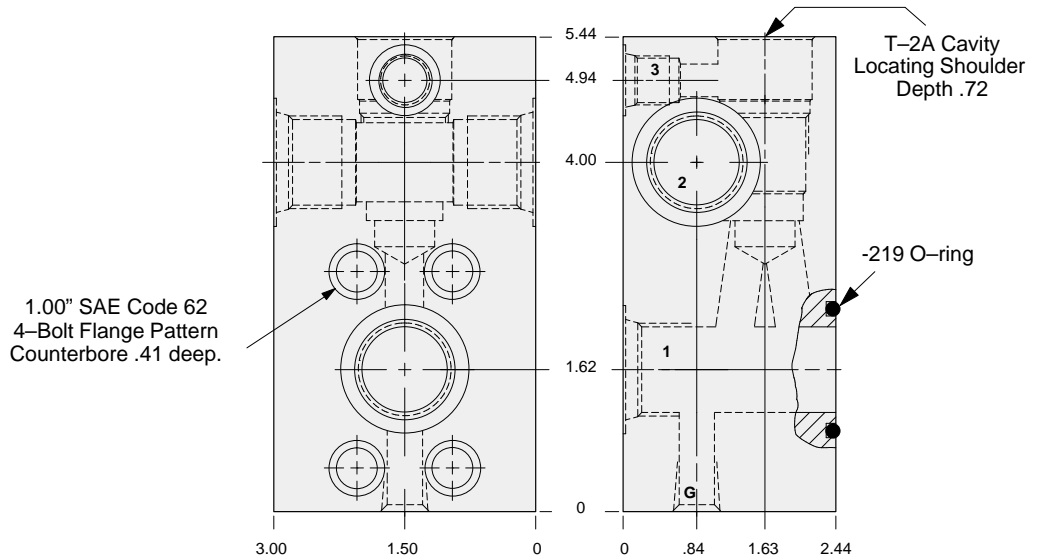

TYPICAL CARTRIDGES USED WITH THIS BODY

RVEA - ***	Page 1.18
RSFC - ***	Page 2.06
SQFB - ***	Page 2.08

Cartridge seal type determines O-ring type.

Instructions for ordering complete cartridge and body assemblies. Page v

Pressure ratings, material specifications. Page 11.02

SAE Specifications Page 11.03

Mounting Hole Dimensions	Ports 1 & 2	Port 3	Gage Port	ALUMINUM		DUCTILE IRON	
				Part Number	List Price	Part Number	List Price
Inch	.75 NPTF	.25 NPTF	.25 NPTF	WYE		WYE/S	
Inch	SAE-12	SAE-6	.25 NPTF	WYD		WYD/S	
Metric	.75 BSPP	.25 BSPP	.25 BSPP	WYC/M		WYC/T	



LINE MOUNT BODIES

- Aluminum rated to 3000 psi.
- Ductile Iron rated to 5000 psi.



S2
T2A

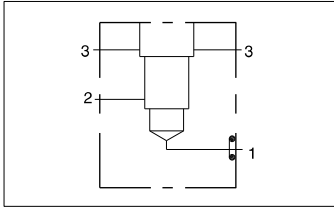

Direct mount .75" SAE Code 61 body with through pilot/drain port.

.75" SAE Code 61
4-Bolt Flange Pattern
2 places.
2 holes tapped
4 holes through

T-2A Cavity
Locating Shoulder
Depth .88

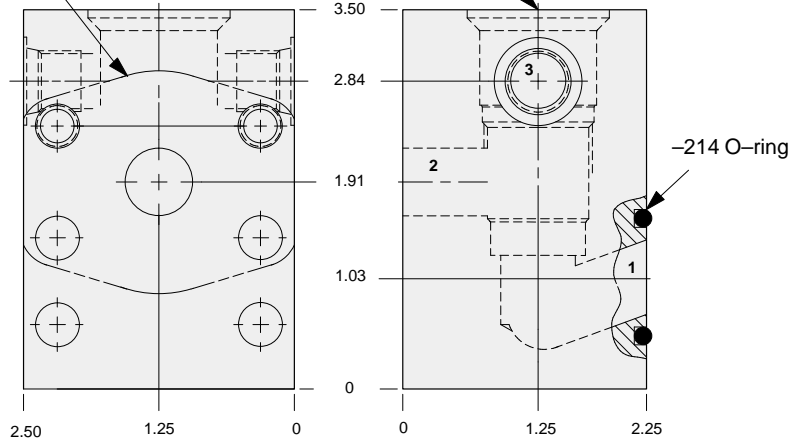

TYPICAL CARTRIDGES USED WITH THIS BODY

RVEA - ***	Page 1.18
RSFC - ***	Page 2.06
SQFB - ***	Page 2.08
RSFE - ***	Page 2.10
SCEA - ***	Page 2.12
CBEA - ***	Page 4.10
CBEG - ***	Page 4.12
CBEH - ***	Page 4.14
CKEB - ***	Page 4.16
LOFC - ***	Page 9.08
LKFC - ***	Page 9.10
LPFC - ***	Page 9.12
LRFC - ***	Page 9.14
COFA - ***	Page 10.12

Cartridge seal type determines O-ring type.

Instructions for ordering complete cartridge and body assemblies. Page v

Pressure ratings, material specifications. Page 11.02

SAE Specifications Page 11.03

Mounting Hole Dimensions	Port 3	ALUMINUM		DUCTILE IRON	
		Part Number	List Price	Part Number	List Price
Inch	SAE-6	ZNV		ZNV/S	
Metric	.25 BSPP	ZNV/M		ZNV/T	

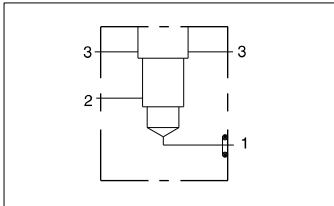

Direct mount .75" SAE Code 62 body with through pilot/drain port.

.75" SAE Code 62
4-Bolt Flange Pattern
2 places.
2 holes tapped
4 holes through

T-2A Cavity
Locating Shoulder
Depth .72

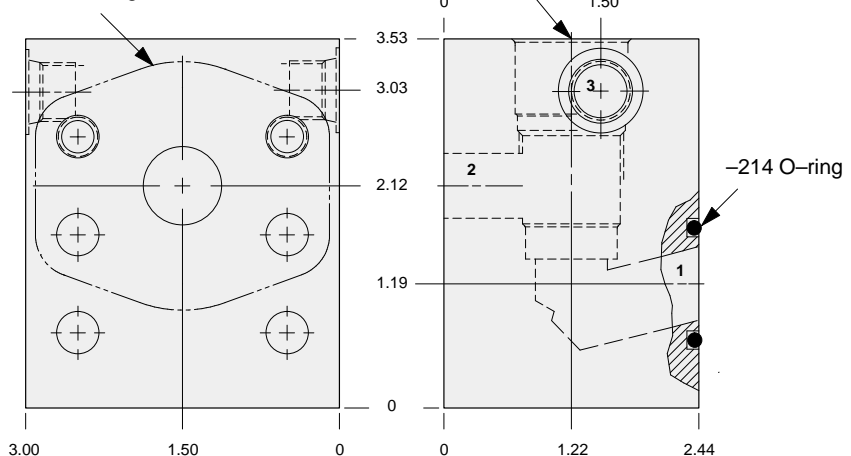

TYPICAL CARTRIDGES USED WITH THIS BODY

RVEA - ***	Page 1.18
RSFC - ***	Page 2.06
SQFB - ***	Page 2.08
RSFE - ***	Page 2.10
SCEA - ***	Page 2.12
CBEA - ***	Page 4.10
CBEG - ***	Page 4.12
CBEH - ***	Page 4.14
CKEB - ***	Page 4.16
LOFC - ***	Page 9.08
LKFC - ***	Page 9.10
LPFC - ***	Page 9.12
LRFC - ***	Page 9.14
COFA - ***	Page 10.12

Cartridge seal type determines O-ring type.

Instructions for ordering complete cartridge and body assemblies. Page v

Pressure ratings, material specifications. Page 11.02

SAE Specifications Page 11.03

Mounting Hole Dimensions	Port 3	ALUMINUM		DUCTILE IRON	
		Part Number	List Price	Part Number	List Price
Inch	SAE-6	ZDS		ZDS/S	
Metric	.25 BSPP	ZDS/M		ZDS/T	



LINE MOUNT BODIES



- Aluminum rated to 3000 psi.
- Ductile Iron rated to 5000 psi.

S2
T2A

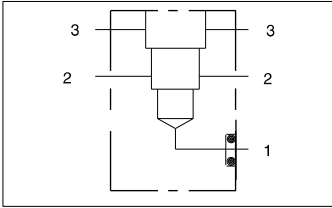

Flange mount through port .75" SAE Code 62 body with through pilot/drain port.

TYPICAL CARTRIDGES USED WITH THIS BODY

- RVEA - *** Page 1.18
 RSFC - *** Page 2.06
 SQFB - *** Page 2.08
 RSFE - *** Page 2.10
 SCEA - *** Page 2.12

Cartridge seal type determines O-ring type.

Instructions for ordering complete cartridge and body assemblies. Page v

Pressure ratings, material specifications. Page 11.02

SAE Specifications Page 11.03

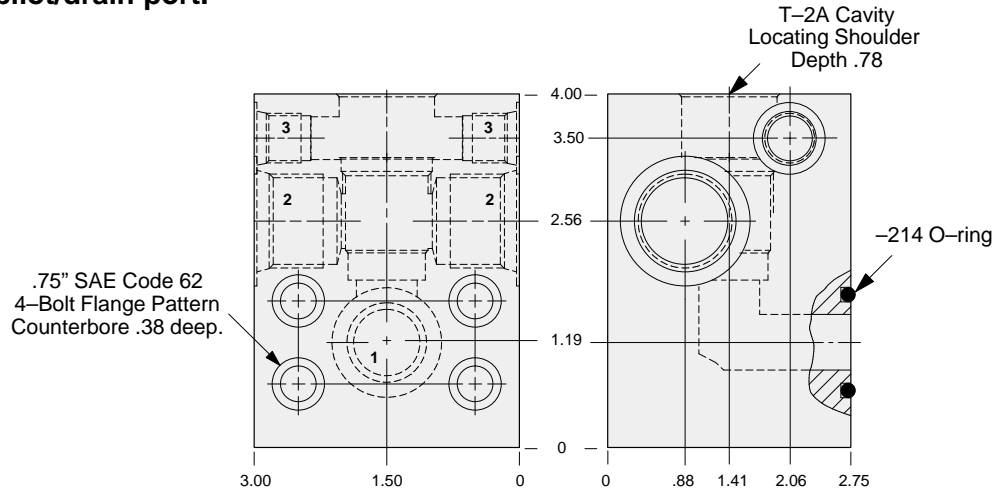

Mounting Hole Dimensions	Port 2	Port 3	ALUMINUM		DUCTILE IRON	
			Part Number	List Price	Part Number	List Price
Inch	.50 NPTF	.25 NPTF	WRA		WRA/S	
Inch	.75 NPTF	.25 NPTF	WRB		WRB/S	
Inch	SAE-10	SAE-6	WRC		WRC/S	
Inch	SAE-12	SAE-6	WRD		WRD/S	
Metric	.50 BSPP	.25 BSPP	WRE/M		WRE/T	
Metric	.75 BSPP	.25 BSPP	WRF/M		WRF/T	

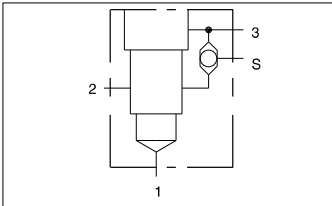

90 degree body with shuttle.

TYPICAL CARTRIDGES USED WITH THIS BODY

- CBEA - *** Page 4.10
 CBEG - *** Page 4.12
 CBEH - *** Page 4.14
 CKEB - *** Page 4.16

Instructions for ordering complete cartridge and body assemblies. Page v

Pressure ratings, material specifications. Page 11.02

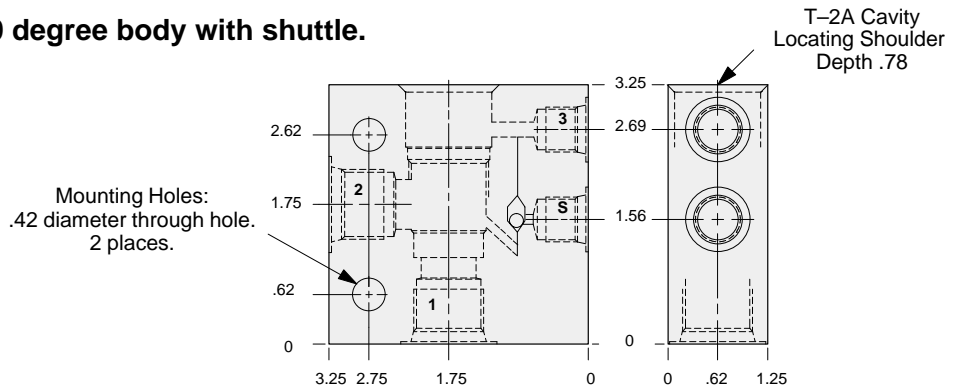

Ports 1 & 2	Ports 3 & S	ALUMINUM		DUCTILE IRON	
		Part Number	List Price	Part Number	List Price
.25 NPTF	.25 NPTF	BGA		BGA/S	
.375 NPTF	.25 NPTF	BGB		BGB/S	
.50 NPTF	.25 NPTF	BGC		BGC/S	
.75 NPTF	.25 NPTF	BGD		BGD/S	
SAE-6	SAE-6	BGI		BGI/S	
SAE-8	SAE-6	BGJ		BGJ/S	
SAE-10	SAE-6	BGK		BGK/S	
.25 BSPP	.25 BSPP	BGT		BGT/S	
.375 BSPP	.25 BSPP	BGU		BGU/S	
.50 BSPP	.25 BSPP	BGV		BGV/S	
.75 BSPP	.25 BSPP	BGW		BGW/S	



LINE MOUNT BODIES



- Aluminum rated to 3000 psi.
- Ductile Iron rated to 5000 psi.

S2
T2A

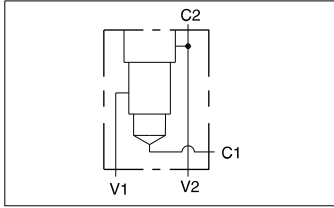

Nipple mount body for load control applications.

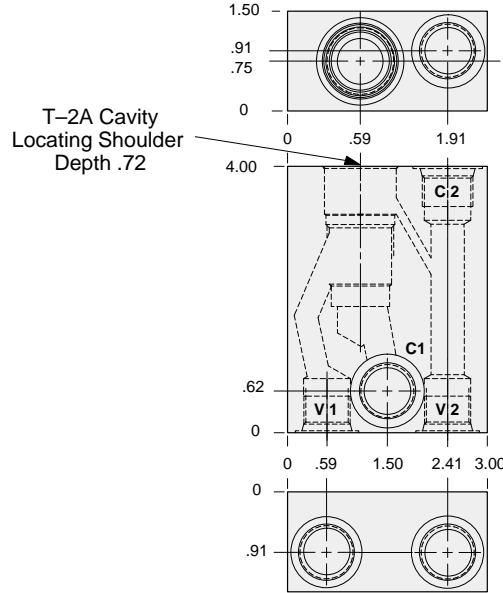

TYPICAL CARTRIDGES USED WITH THIS BODY

- CBEA - *** Page 4.10
- CBEG - *** Page 4.12
- CBEH - *** Page 4.14
- CKEB - *** Page 4.16

Instructions for ordering complete cartridge and body assemblies. Page v

Pressure ratings, material specifications. Page 11.02

All Ports	ALUMINUM		DUCTILE IRON	
	Part Number	List Price	Part Number	List Price
.50 NPTF	ZTX		ZTX/S	
SAE-8	ZRM		ZRM/S	

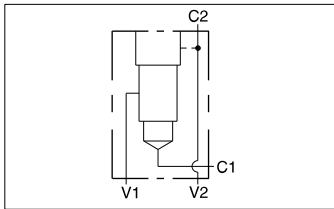

Gasket mount body for load control applications.

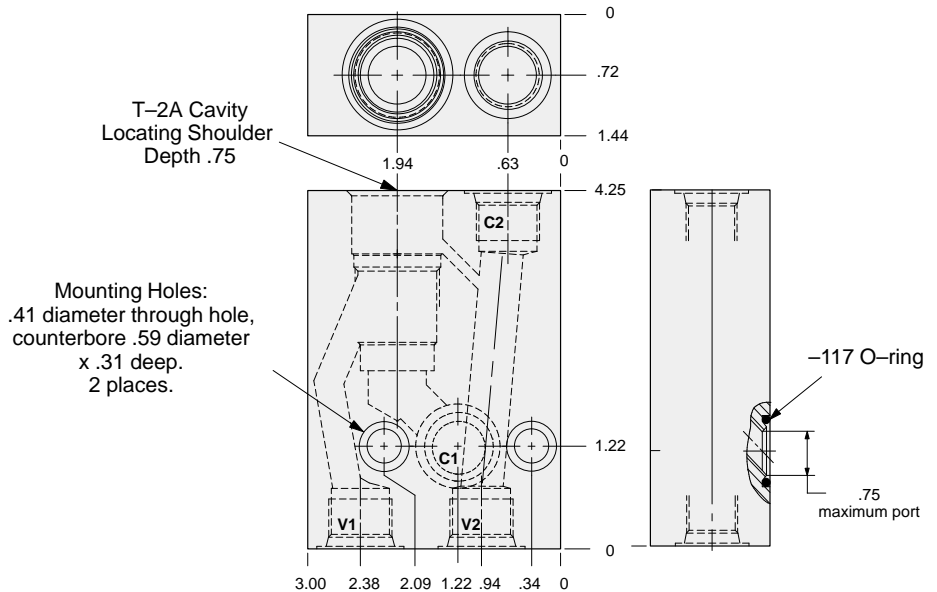

TYPICAL CARTRIDGES USED WITH THIS BODY

- CBEA - *** Page 4.10
- CBEG - *** Page 4.12
- CBEH - *** Page 4.14
- CKEB - *** Page 4.16

Cartridge seal type determines O-ring type.

Instructions for ordering complete cartridge and body assemblies. Page v

Pressure ratings, material specifications. Page 11.02

Mounting Holes:
.41 diameter through hole,
counterbore .59 diameter
x .31 deep.
2 places.

Ports C2, V1, & V2	ALUMINUM		DUCTILE IRON	
	Part Number	List Price	Part Number	List Price
.50 NPTF	ZTF		ZTF/S	
SAE-8	ZTG		ZTG/S	
.50 BSPP	ZTH		ZTH/S	



LINE MOUNT BODIES



- Aluminum rated to 3000 psi.
- Ductile Iron rated to 5000 psi.

S2
T2A

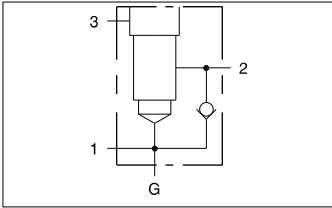

Body with reverse free flow check and gage port for reducing and reducing/relieving applications.

TYPICAL CARTRIDGES USED WITH THIS BODY

PBFB - ***	Page 3.06
PBFC - ***	Page 3.08
PPFB - ***	Page 3.10
PPFC - ***	Page 3.12

Cartridge seal type determines check valve seal type.

Instructions for ordering complete cartridge and body assemblies. Page v

Pressure ratings, material specifications. Page 11.02

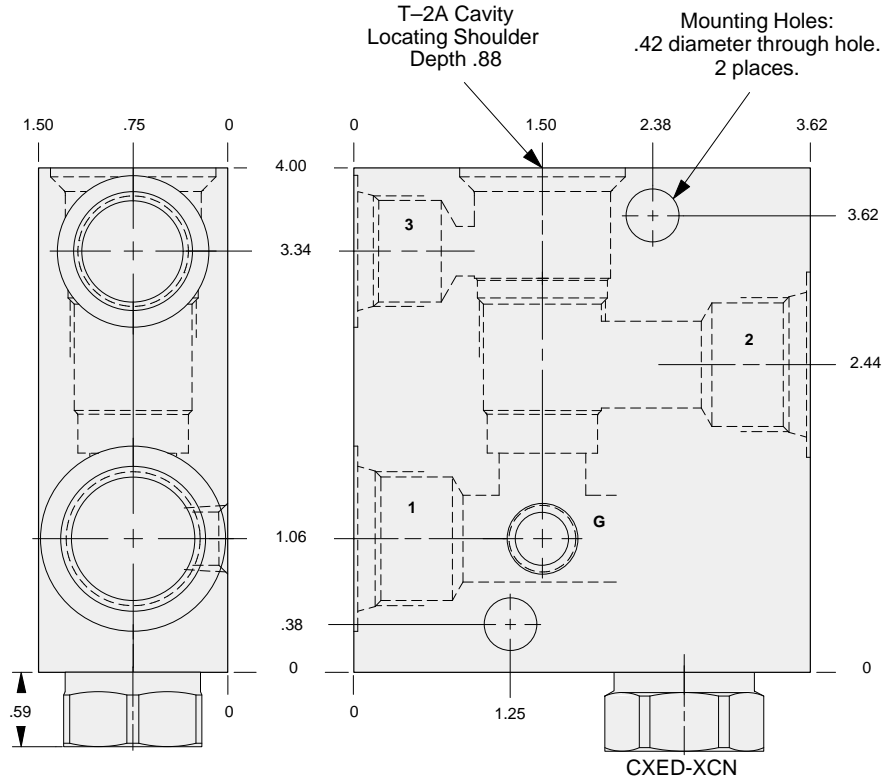

Ports 1 & 2	Port 3	Gage Port	ALUMINUM		DUCTILE IRON	
			Part Number	List Price	Part Number	List Price
.25 NPTF	.25 NPTF	.25 NPTF	B2A		B2A/S	
.375 NPTF	.25 NPTF	.25 NPTF	B2B		B2B/S	
.50 NPTF	.25 NPTF	.25 NPTF	B2C		B2C/S	
.75 NPTF	.25 NPTF	.25 NPTF	B2D		B2D/S	
SAE-6	SAE-6	.25 NPTF	B2I		B2I/S	
SAE-8	SAE-6	.25 NPTF	B2J		B2J/S	
SAE-10	SAE-6	.25 NPTF	B2K		B2K/S	
.375 BSPP	.25 BSPP	.25 BSPP	B2U		B2U/S	
.50 BSPP	.25 BSPP	.25 BSPP	B2V		B2V/S	
.75 BSPP	.25 BSPP	.25 BSPP	B2W		B2W/S	
.375 NPTF	.375 NPTF	.25 NPTF	B4B		B4B/S	
.50 NPTF	.50 NPTF	.25 NPTF	B4C		B4C/S	
.75 NPTF	.50 NPTF	.25 NPTF	B4D		B4D/S	
SAE-8	SAE-8	.25 NPTF	B4J		B4J/S	
SAE-10	SAE-10	.25 NPTF	B4K		B4K/S	
SAE-12	SAE-10	.25 NPTF	B4L		B4L/S	
.375 BSPP	.375 BSPP	.25 BSPP	B4U		B4U/S	
.50 BSPP	.50 BSPP	.25 BSPP	B4V		B4V/S	
.75 BSPP	.50 BSPP	.25 BSPP	B4W		B4W/S	



LINE MOUNT BODIES



- Aluminum rated to 3000 psi.
- Ductile Iron rated to 5000 psi.

S2
T2A

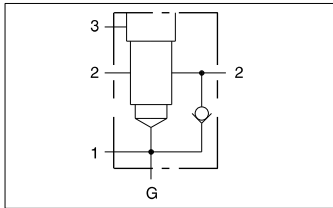

Through port body with reverse free flow check and gage port for reducing applications.

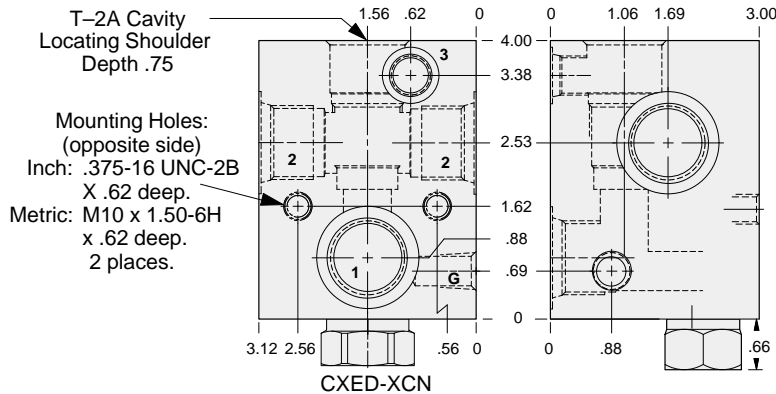

TYPICAL CARTRIDGES USED WITH THIS BODY

PBFB - *** Page 3.06
 PBFC - *** Page 3.08

Cartridge seal type determines check valve seal type.

Instructions for ordering complete cartridge and body assemblies. Page v

Pressure ratings, material specifications. Page 11.02

Mounting Hole Dimensions	Ports 1 & 2	Port 3	Gage Port	ALUMINUM		DUCTILE IRON	
				Part Number	List Price	Part Number	List Price
Inch	.375 NPTF	.25 NPTF	.25 NPTF	B3B		B3B/S	
Inch	.50 NPTF	.25 NPTF	.25 NPTF	B3C		B3C/S	
Inch	.75 NPTF	.25 NPTF	.25 NPTF	B3D		B3D/S	
Inch	SAE-8	SAE-6	.25 NPTF	B3J		B3J/S	
Inch	SAE-10	SAE-6	.25 NPTF	B3K		B3K/S	
Inch	SAE-12	SAE-6	.25 NPTF	B3L		B3L/S	
Metric	.375 BSPP	.25 BSPP	.25 BSPP	B3U		B3U/S	
Metric	.50 BSPP	.25 BSPP	.25 BSPP	B3V		B3V/S	
Metric	.75 BSPP	.25 BSPP	.25 BSPP	B3W		B3W/S	

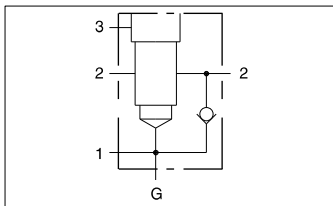

Through port body with high capacity port 3.

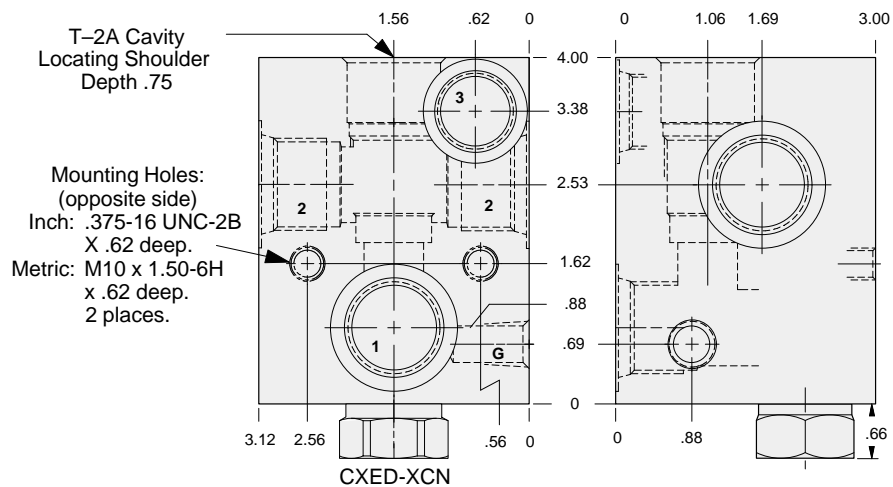

TYPICAL CARTRIDGES USED WITH THIS BODY

PPFB - *** Page 3.10
 PPFC - *** Page 3.12

Cartridge seal type determines check valve seal type.

Instructions for ordering complete cartridge and body assemblies. Page v

Pressure ratings, material specifications. Page 11.02

Mounting Hole Dimensions	Ports 1 & 2	Port 3	Gage Port	ALUMINUM		DUCTILE IRON	
				Part Number	List Price	Part Number	List Price
Inch	.50 NPTF	.50 NPTF	.25 NPTF	B5C		B5C/S	
Inch	.75 NPTF	.50 NPTF	.25 NPTF	B5D		B5D/S	
Inch	SAE-10	SAE-10	.25 NPTF	B5K		B5K/S	
Inch	SAE-12	SAE-10	.25 NPTF	B5L		B5L/S	
Metric	.50 BSPP	.50 BSPP	.25 BSPP	B5V		B5V/S	
Metric	.75 BSPP	.50 BSPP	.25 BSPP	B5W		B5W/S	



LINE MOUNT BODIES



- Aluminum rated to 3000 psi.
- Ductile Iron rated to 5000 psi.

S2
T2A

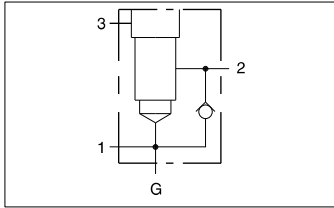

Body with reverse free flow check and gage port.

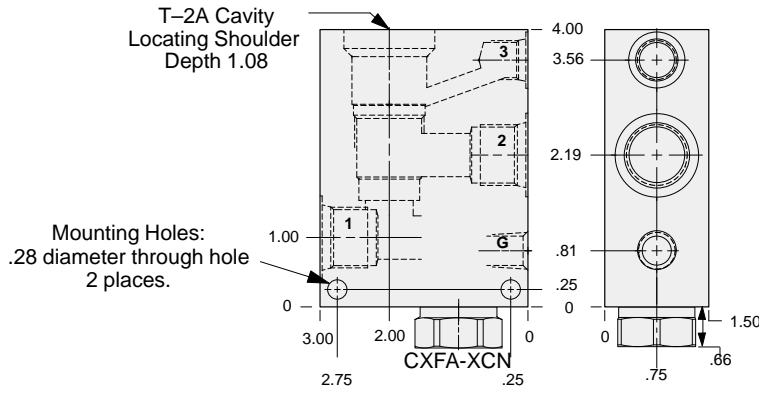

TYPICAL CARTRIDGES USED WITH THIS BODY

- RVEA - *** Page 1.18
 RSFC - *** Page 2.06
 SQFB - *** Page 2.08
 RSFE - *** Page 2.10

Cartridge seal type determines check valve seal type.

Instructions for ordering complete cartridge and body assemblies. Page v

Pressure ratings, material specifications. Page 11.02

Ports 1 & 2	Port 3	Gage Port	ALUMINUM		DUCTILE IRON	
			Part Number	List Price	Part Number	List Price
.25 NPTF	.25 NPTF	.25 NPTF	B6A		B6A/S	
.375 NPTF	.25 NPTF	.25 NPTF	B6B		B6B/S	
.50 NPTF	.25 NPTF	.25 NPTF	B6C		B6C/S	
.75 NPTF	.25 NPTF	.25 NPTF	B6D		B6D/S	
SAE-6	SAE-6	.25 NPTF	B6I		B6I/S	
SAE-8	SAE-6	.25 NPTF	B6J		B6J/S	
SAE-10	SAE-6	.25 NPTF	B6K		B6K/S	
.375 BSPP	.25 BSPP	.25 BSPP	B6U		B6U/S	
.50 BSPP	.25 BSPP	.25 BSPP	B6V		B6V/S	
.75 BSPP	.25 BSPP	.25 BSPP	B6W		B6W/S	

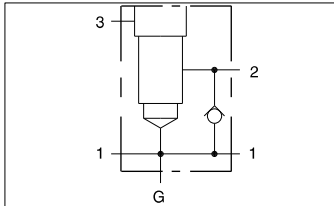

Through port body with reverse free flow check and gage port.

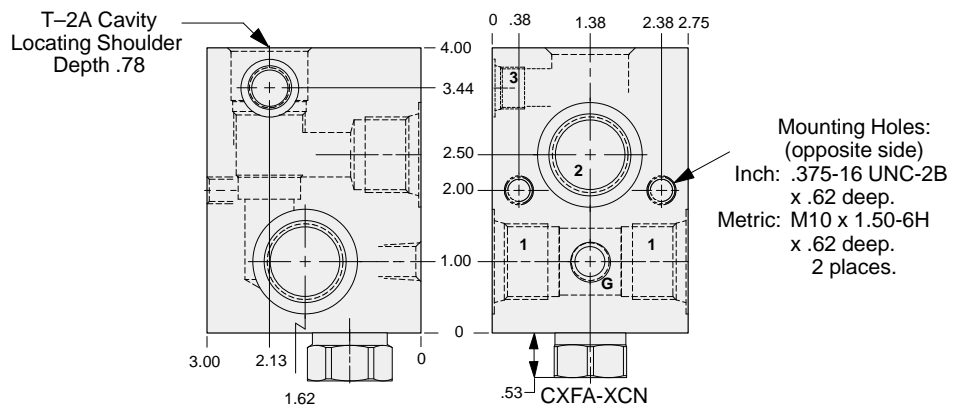

TYPICAL CARTRIDGES USED WITH THIS BODY

- RVEA - *** Page 1.18
 RSFC - *** Page 2.06
 SQFB - *** Page 2.08
 RSFE - *** Page 2.10

Cartridge seal type determines check valve seal type.

Instructions for ordering complete cartridge and body assemblies. Page v

Pressure ratings, material specifications. Page 11.02

Mounting Hole Dimensions	Ports 1 & 2	Port 3	Gage Port	ALUMINUM		DUCTILE IRON	
				Part Number	List Price	Part Number	List Price
Inch	.375 NPTF	.25 NPTF	.25 NPTF	B7B		B7B/S	
Inch	.50 NPTF	.25 NPTF	.25 NPTF	B7C		B7C/S	
Inch	.75 NPTF	.25 NPTF	.25 NPTF	B7D		B7D/S	
Inch	SAE-8	SAE-6	.25 NPTF	B7J		B7J/S	
Inch	SAE-10	SAE-6	.25 NPTF	B7K		B7K/S	
Inch	SAE-12	SAE-6	.25 NPTF	B7L		B7L/S	
Metric	.375 BSPP	.25 BSPP	.25 BSPP	B7U		B7U/S	
Metric	.50 BSPP	.25 BSPP	.25 BSPP	B7V		B7V/S	
Metric	.75 BSPP	.25 BSPP	.25 BSPP	B7W		B7W/S	



LINE MOUNT BODIES



- Aluminum rated to 3000 psi.
- Ductile Iron rated to 5000 psi.

S2
T2A

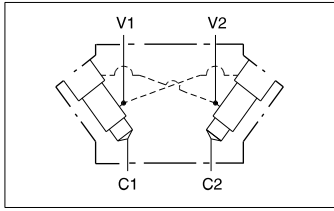

Two cavity inline cross-piloted body for load control applications.

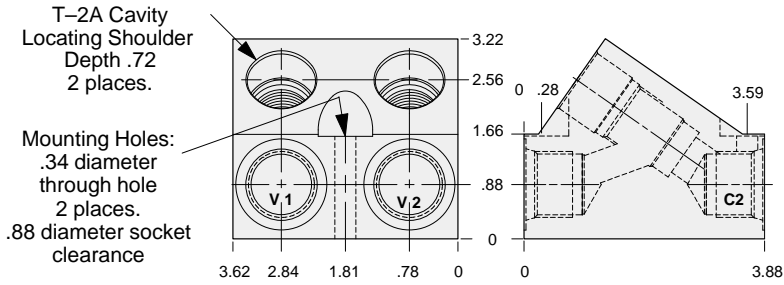

TYPICAL CARTRIDGES USED WITH THIS BODY

- CBEA - *** Page 4.10
 CBEG - *** Page 4.12
 CBEH - *** Page 4.14
 CKEB - *** Page 4.16

Instructions for ordering complete cartridge and body assemblies. Page v

Pressure ratings, material specifications. Page 11.02

Ports C1, C2, & V1, V2	ALUMINUM		DUCTILE IRON	
	Part Number	List Price	Part Number	List Price
.25 NPTF	XAA		XAA/S	
.375 NPTF	XAB		XAB/S	
.50 NPTF	XAC		XAC/S	
.75 NPTF	XAD		XAD/S	
SAE-6	XAI		XAI/S	
SAE-8	XAJ		XAJ/S	
SAE-10	XAK		XAK/S	
SAE-12	XAL		XAL/S	
.25 BSPP	XAT		XAT/S	
.375 BSPP	XAU		XAU/S	
.50 BSPP	XAV		XAV/S	
.75 BSPP	XAW		XAW/S	

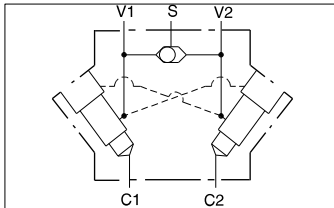

Two cavity inline cross-piloted body with shuttle for load control applications.

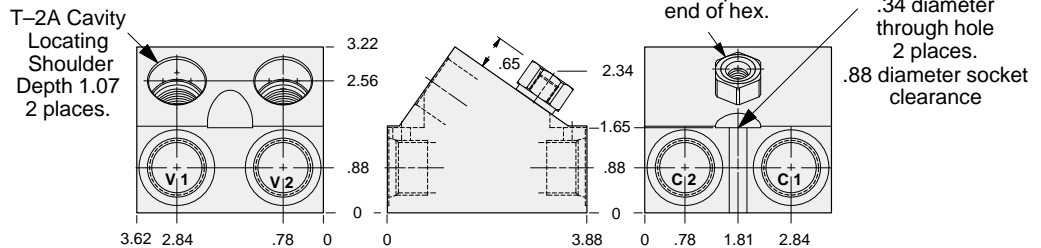

TYPICAL CARTRIDGES USED WITH THIS BODY

- CBEA - *** Page 4.10
 CBEG - *** Page 4.12
 CBEH - *** Page 4.14
 CKEB - *** Page 4.16

Cartridge seal type determines shuttle valve seal type.

Instructions for ordering complete cartridge and body assemblies. Page v

Pressure ratings, material specifications. Page 11.02

Ports C1, C2, & V1, V2	Shuttle Cartridge	Shuttle Port	ALUMINUM		DUCTILE IRON	
			Part Number	List Price	Part Number	List Price
.25 NPTF	CSAA - EXN	SAE-4	XHA		XHA/S	
.375 NPTF	CSAA - EXN	SAE-4	XHB		XHB/S	
.50 NPTF	CSAA - EXN	SAE-4	XHC		XHC/S	
.75 NPTF	CSAA - EXN	SAE-4	XHD		XHD/S	
SAE-6	CSAA - EXN	SAE-4	XHI		XHI/S	
SAE-8	CSAA - EXN	SAE-4	XHJ		XHJ/S	
SAE-10	CSAA - EXN	SAE-4	XHK		XHK/S	
SAE-12	CSAA - EXN	SAE-4	XHL		XHL/S	
.25 BSPP	CSAA - BXN	.25 BSPP	XHT		XHT/S	
.375 BSPP	CSAA - BXN	.25 BSPP	XHU		XHU/S	
.50 BSPP	CSAA - BXN	.25 BSPP	XHV		XHV/S	
.75 BSPP	CSAA - BXN	.25 BSPP	XHW		XHW/S	



LINE MOUNT BODIES



- Aluminum rated to 3000 psi.
- Ductile Iron rated to 5000 psi.

S2
T2A

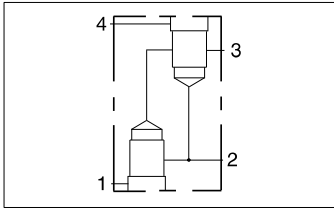

Two cavity body for flow control applications.

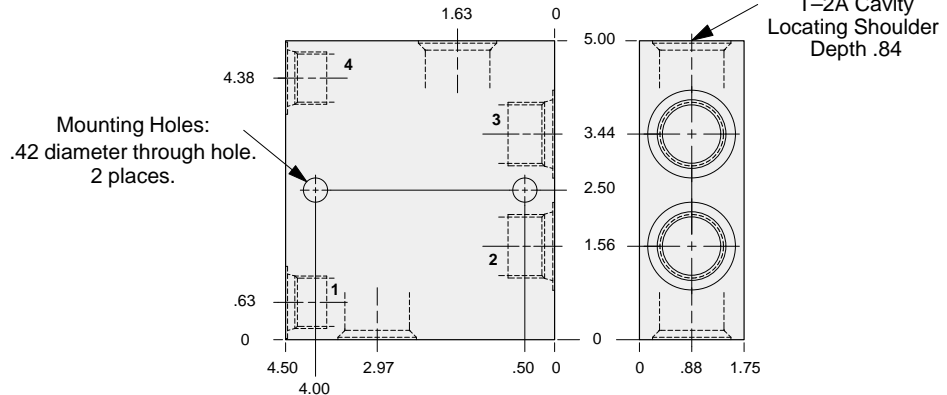

TYPICAL CARTRIDGES USED WITH THIS BODY

FRDA - *** Page 6.02

Instructions for ordering complete cartridge and body assemblies. Page v

Pressure ratings, material specifications. Page 11.02

Port 2 & 3	Port 1 & 4	ALUMINUM		DUCTILE IRON	
		Part Number	List Price	Part Number	List Price
.375 NPTF	.375 NPTF	VXN		VXN/S	
.50 NPTF	.50 NPTF	VXP		VXP/S	
.75 NPTF	.50 NPTF	VXQ		VXQ/S	
SAE-8	SAE-8	VXR		VXR/S	
SAE-10	SAE-10	VXS		VXS/S	
SAE-12	SAE-10	VXT		VXT/S	
.375 BSPP	.375 BSPP	VXU		VXU/S	
.50 BSPP	.50 BSPP	VXV		VXV/S	
.75 BSPP	.50 BSPP	VXW		VXW/S	

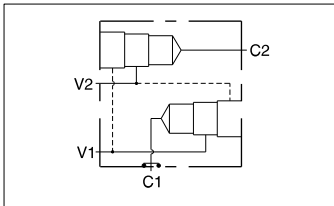

Two cavity gasket mount body for load control applications.

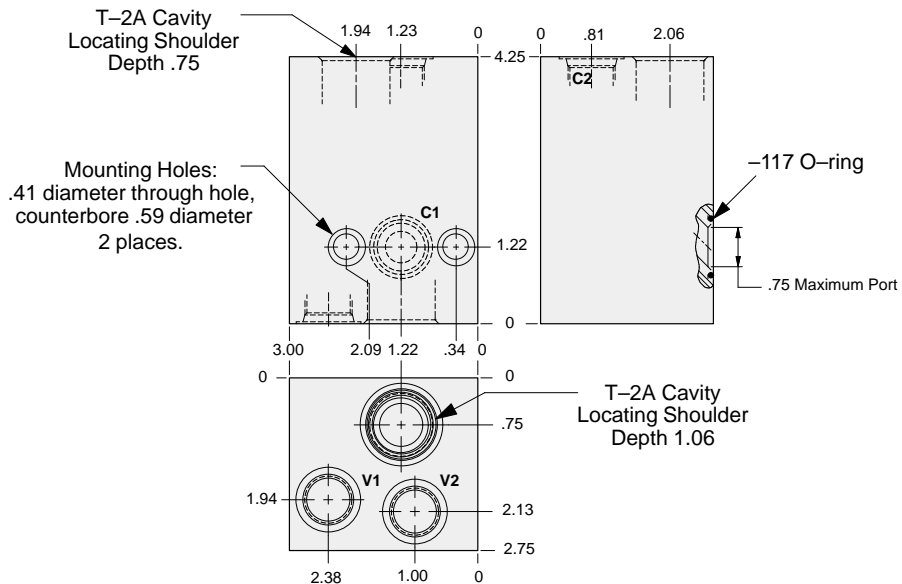

TYPICAL CARTRIDGES USED WITH THIS BODY

CBEA - *** Page 4.10
 CBEG - *** Page 4.12
 CBEH - *** Page 4.14
 CKEB - *** Page 4.16

Cartridge seal type determines O-ring type.

Instructions for ordering complete cartridge and body assemblies. Page v

Pressure ratings, material specifications. Page 11.02

Ports C2, V1 & V2	ALUMINUM		DUCTILE IRON	
	Part Number	List Price	Part Number	List Price
.50 NPTF	YVW		YVW/S	
SAE-8	YVV		YVV/S	
.50 BSPP	YVU		YVU/S	



LINE MOUNT BODIES



- Aluminum rated to 3000 psi.
- Ductile Iron rated to 5000 psi.

S2
T2A

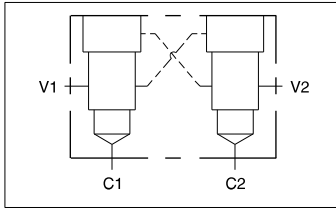

Two cavity 90 degree cross-piloted body for load control applications.

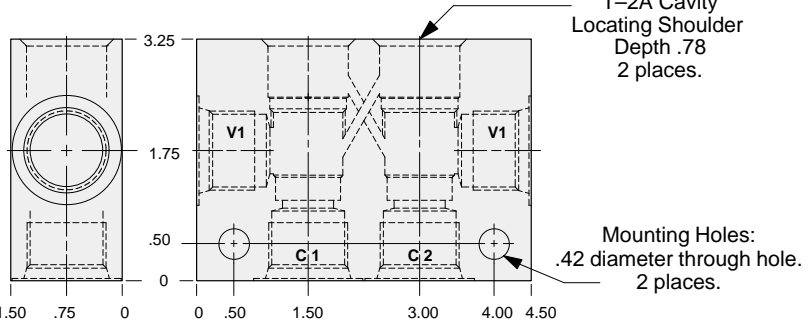

TYPICAL CARTRIDGES USED WITH THIS BODY

- CBEA - *** Page 4.10
 CBEG - *** Page 4.12
 CBEH - *** Page 4.14
 CKEB - *** Page 4.16

Instructions for ordering complete cartridge and body assemblies. Page v

Pressure ratings, material specifications. Page 11.02

Ports C1, C2, & V1, V2	ALUMINUM		DUCTILE IRON	
	Part Number	List Price	Part Number	List Price
.25 NPTF	YAA		YAA/S	
.375 NPTF	YAB		YAB/S	
.50 NPTF	YAC		YAC/S	
.75 NPTF	YAD		YAD/S	
SAE-6	YAI		YAI/S	
SAE-8	YAJ		YAJ/S	
SAE-10	YAK		YAK/S	
SAE-12	YAL		YAL/S	
.25 BSPP	YAT		YAT/S	
.375 BSPP	YAU		YAU/S	
.50 BSPP	YAV		YAV/S	

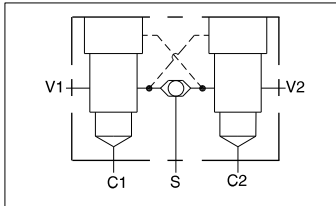

Two cavity 90 degree cross-piloted body with shuttle for load control applications.

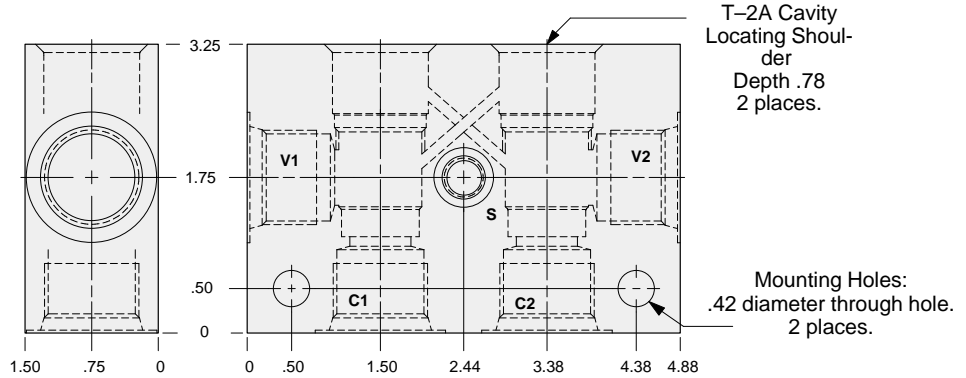

TYPICAL CARTRIDGES USED WITH THIS BODY

- CBEA - *** Page 4.10
 CBEG - *** Page 4.12
 CBEH - *** Page 4.14
 CKEB - *** Page 4.16

Instructions for ordering complete cartridge and body assemblies. Page v

Pressure ratings, material specifications. Page 11.02

Ports C1, C2, & V1, V2	Port S	ALUMINUM		DUCTILE IRON	
		Part Number	List Price	Part Number	List Price
.50 NPTF	.25 NPTF	YHC		YHC/S	
.75 NPTF	.25 NPTF	YHD		YHD/S	
SAE-10	SAE-4	YHK		YHK/S	
SAE-12	SAE-4	YHL		YHL/S	
.50 BSPP	.25 BSPP	YHV		YHV/S	
.75 BSPP	.25 BSPP	YHW		YHW/S	



LINE MOUNT BODIES



- Aluminum rated to 3000 psi.
- Ductile Iron rated to 5000 psi.

S2
T2A

Two cavity dual load control body with checks.

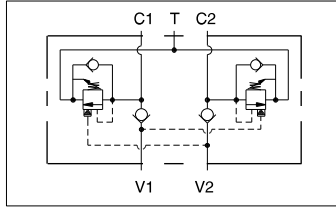
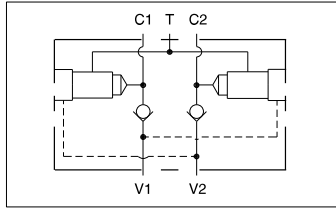

TYPICAL CARTRIDGES USED WITH THIS BODY

- CBEA - *** Page 4.10
 CBEG - *** Page 4.12
 CBEH - *** Page 4.14

Cartridge seal type determines check valve seal type.

Instructions for ordering complete cartridge and body assemblies. Page v

Pressure ratings, material specifications. Page 11.02

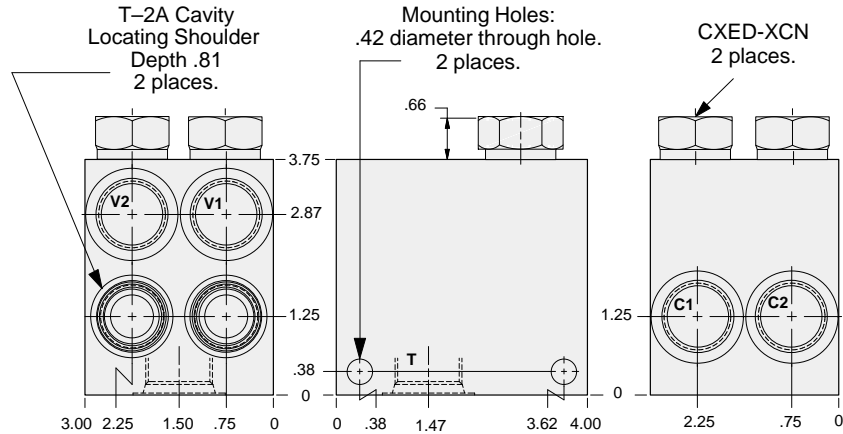

Ports C1, C2, & V1, V2	Port T	ALUMINUM		DUCTILE IRON	
		Part Number	List Price	Part Number	List Price
.50 NPTF	.75 NPTF	BMC		BMC/S	
.75 NPTF	.75 NPTF	BMD		BMD/S	
SAE-10	SAE-12	BMK		BMK/S	
SAE-12	SAE-12	BML		BML/S	
.50 BSPP	.75 BSPP	BMV		BMV/S	
.75 BSPP	.75 BSPP	BMW		BMW/S	

Discharge oil returns to tank through port T.

Two cavity dual load control body with checks and shuttle.

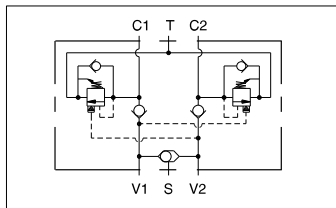
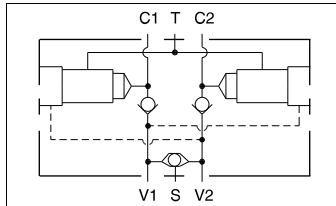

TYPICAL CARTRIDGES USED WITH THIS BODY

- CBEA - *** Page 4.10
 CBEG - *** Page 4.12
 CBEH - *** Page 4.14

Cartridge seal type determines check valve seal type.

Instructions for ordering complete cartridge and body assemblies. Page v

Pressure ratings, material specifications. Page 11.02

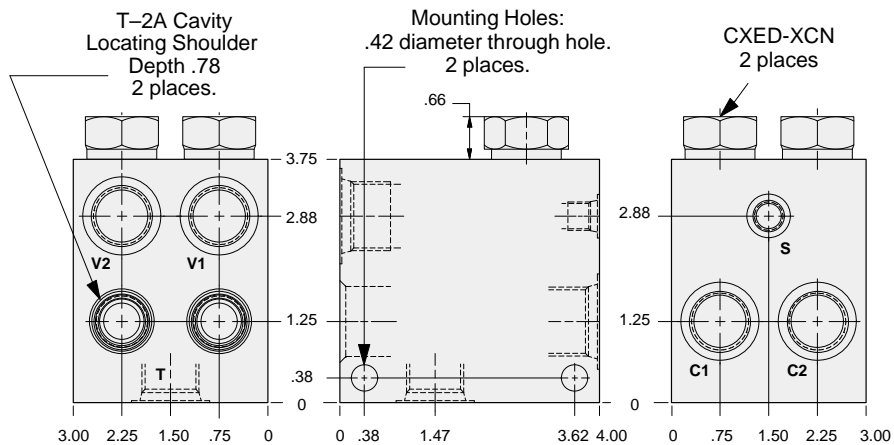

Ports C1, C2, & V1, V2	Port T	Port S	ALUMINUM		DUCTILE IRON	
			Part Number	List Price	Part Number	List Price
.50 NPTF	.75 NPTF	.25 NPTF	BNC		BNC/S	
.75 NPTF	.75 NPTF	.25 NPTF	BND		BND/S	
SAE-10	SAE-12	SAE-4	BNK		BNK/S	
SAE-12	SAE-12	SAE-4	BNL		BNL/S	
.50 BSPP	.75 BSPP	.25 BSPP	BNV		BNV/S	
.75 BSPP	.75 BSPP	.25 BSPP	BNW		BNW/S	

Discharge oil returns to tank through port T.



LINE MOUNT BODIES



- Aluminum rated to 3000 psi.
- Ductile Iron rated to 5000 psi.

S2
T2A

Two cavity dual load control body with make-up checks.

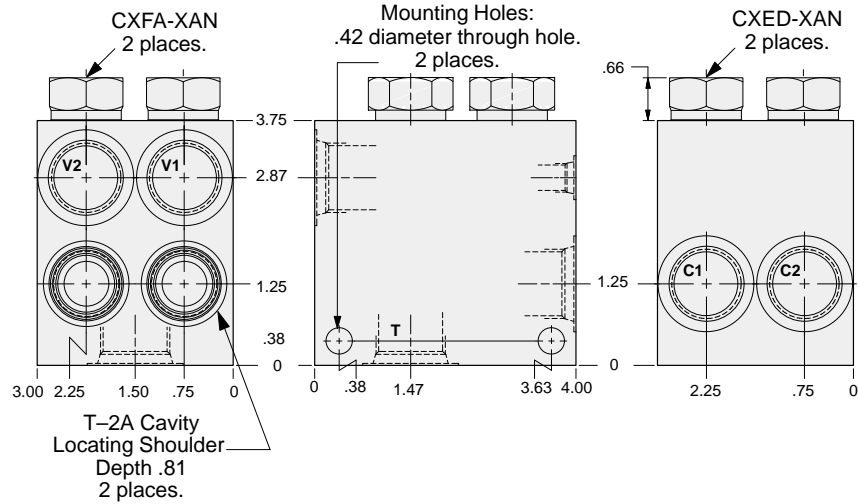
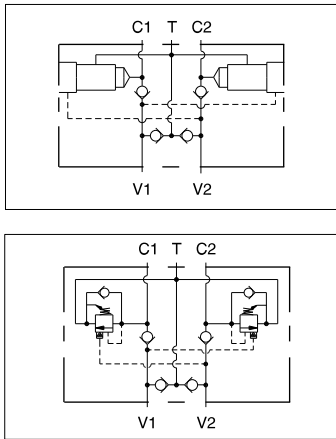

TYPICAL CARTRIDGES USED WITH THIS BODY

- CBEA - *** Page 4.10
 CBEG - *** Page 4.12
 CBEH - *** Page 4.14

Cartridge seal type determines check valve seal type.

Instructions for ordering complete cartridge and body assemblies. Page v

Pressure ratings, material specifications. Page 11.02

Ports C1, C2, & V1, V2	Port T	ALUMINUM		DUCTILE IRON	
		Part Number	List Price	Part Number	List Price
.50 NPTF	.75 NPTF	BPC		BPC/S	
.75 NPTF	.75 NPTF	BPD		BPD/S	
SAE-10	SAE-12	BPK		BPK/S	
SAE-12	SAE-12	BPL		BPL/S	
.50 BSPP	.75 BSPP	BPV		BPV/S	
.75 BSPP	.75 BSPP	BPW		BPW/S	

Discharge oil returns to tank through directional valve or port T.

Two cavity dual load control body with make-up checks and shuttle.

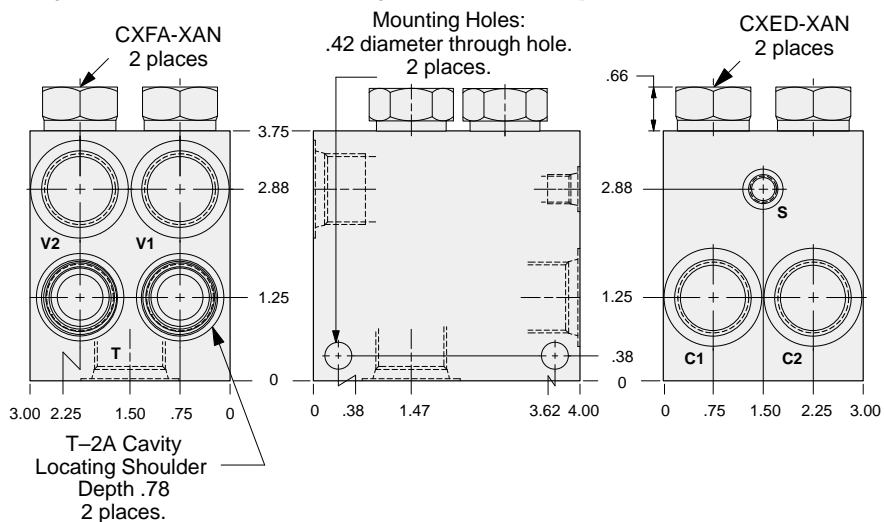
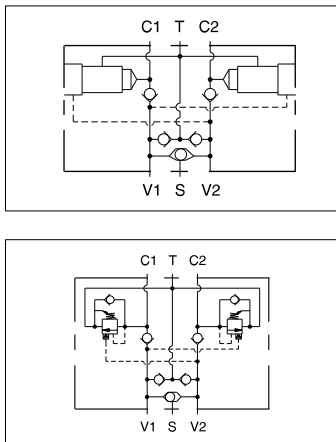

TYPICAL CARTRIDGES USED WITH THIS BODY

- CBEA - *** Page 4.10
 CBEG - *** Page 4.12
 CBEH - *** Page 4.14

Cartridge seal type determines check valve seal type.

Instructions for ordering complete cartridge and body assemblies. Page v

Pressure ratings, material specifications. Page 11.02

Ports C1, C2, & V1, V2	Port T	Port S	ALUMINUM		DUCTILE IRON	
			Part Number	List Price	Part Number	List Price
.50 NPTF	.75 NPTF	.25 NPTF	BQC		BQC/S	
.75 NPTF	.75 NPTF	.25 NPTF	BQD		BQD/S	
SAE-10	SAE-12	SAE-4	BQK		BQK/S	
SAE-12	SAE-12	SAE-4	BQL		BQL/S	
.50 BSPP	.75 BSPP	.25 BSPP	BQV		BQV/S	
.75 BSPP	.75 BSPP	.25 BSPP	BQW		BQW/S	

Discharge oil returns to tank through directional valve or port T.



LINE MOUNT BODIES



- Aluminum rated to 3000 psi.
- Ductile Iron rated to 5000 psi.

S2
T2A

Two cavity dual sequence body with reverse free flow checks.

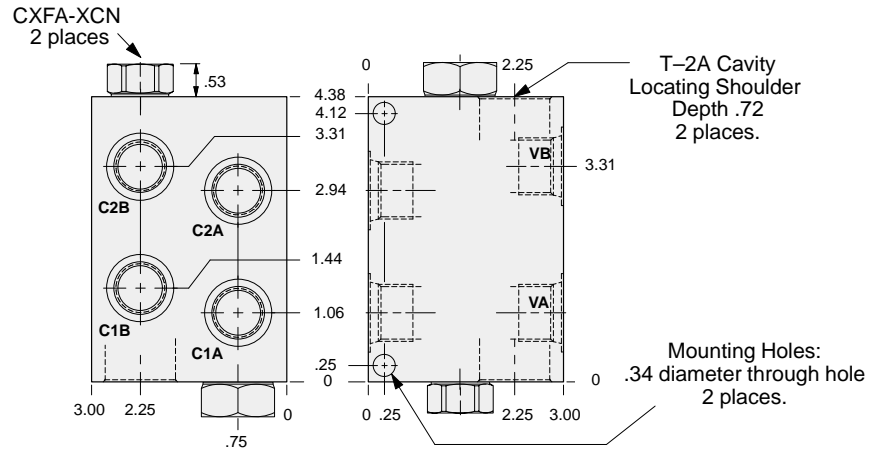
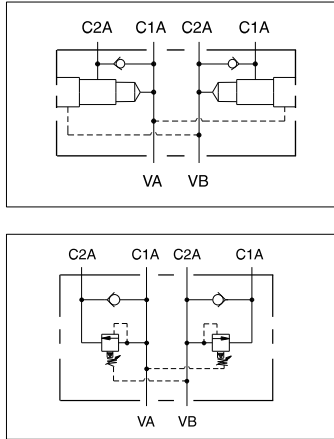

TYPICAL CARTRIDGES USED WITH THIS BODY

RSFC - *** Page 2.06
SQFB - *** Page 2.08

Cartridge seal type determines check valve seal type.

Instructions for ordering complete cartridge and body assemblies. Page v

Pressure ratings, material specifications. Page 11.02

All Ports	ALUMINUM		DUCTILE IRON	
	Part Number	List Price	Part Number	List Price
.375 NPTF	B8B		B8B/S	
.50 NPTF	B8C		B8C/S	
.75 NPTF	B8D		B8D/S	
SAE-8	B8J		B8J/S	
SAE-10	B8K		B8K/S	
.375 BSPP	B8U		B8U/S	
.50 BSPP	B8V		B8V/S	
.75 BSPP	B8W		B8W/S	

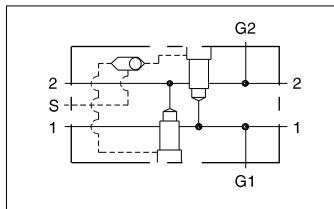

Two cavity through port body with shuttle and gage ports.

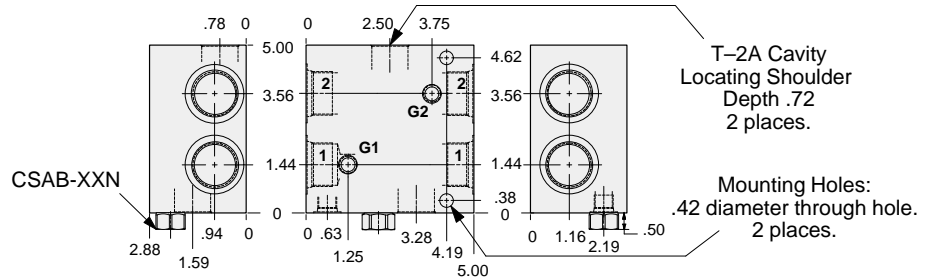

TYPICAL CARTRIDGES USED WITH THIS BODY

RVEA - *** Page 1.18

Cartridge seal type determines shuttle valve seal type.

Instructions for ordering complete cartridge and body assemblies. Page v

Pressure ratings, material specifications. Page 11.02

Ports 1 & 2	Ports G1 & G2	Port V	ALUMINUM		DUCTILE IRON	
			Part Number	List Price	Part Number	List Price
.375 NPTF	.25 NPTF	.25 NPTF	XBB		XBB/S	
.50 NPTF	.25 NPTF	.25 NPTF	XBC		XBC/S	
.75 NPTF	.25 NPTF	.25 NPTF	XBD		XBD/S	
1.00 NPTF	.25 NPTF	.25 NPTF	XBE		XBE/S	
SAE-6	.25 NPTF	SAE-6	XBI		XBI/S	
SAE-8	.25 NPTF	SAE-6	XBJ		XBJ/S	
SAE-10	.25 NPTF	SAE-6	XBK		XBK/S	
SAE-12	.25 NPTF	SAE-6	XBL		XBL/S	
SAE-16	.25 NPTF	SAE-6	XBM		XBM/S	
.375 BSPP	.25 BSPP	.25 BSPP	XBU		XBU/S	
.50 BSPP	.25 BSPP	.25 BSPP	XBV		XBV/S	
.75 BSPP	.25 BSPP	.25 BSPP	XBW		XBW/S	
1.00 BSPP	.25 BSPP	.25 BSPP	XBX		XBX/S	



LINE MOUNT BODIES



- Aluminum rated to 3000 psi.
- Ductile Iron rated to 5000 psi.

S2
T2A

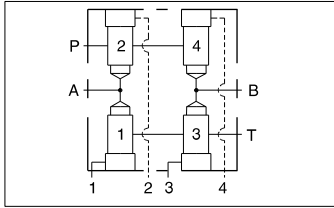

Four cavity four-way logic body for directional applications.

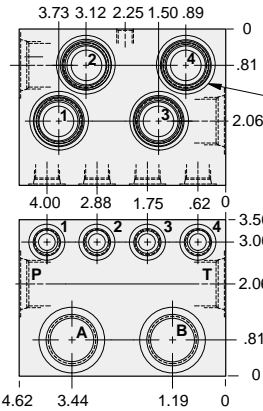

T-2A Cavity
Locating Shoulder
Depth .72
4 places.

Mounting Holes:
Inch: .375-16 UNC-2B
x .62 deep.
Metric: M10 x 1.50-6H
x .62 deep.
2 places.

TYPICAL CARTRIDGES USED WITH THIS BODY

- LOFC - *** Page 9.08
LKFC - *** Page 9.10
LPFC - *** Page 9.12
LRFC - *** Page 9.14

Instructions for ordering complete cartridge and body assemblies. Page v

Pressure ratings, material specifications. Page 11.02

Mounting Hole Dimensions	Ports A & B P & T	Ports 1 & 2, 3 & 4	ALUMINUM		DUCTILE IRON	
			Part Number	List Price	Part Number	List Price
Inch	.375 NPTF	.25 NPTF	YPZ		YPZ/S	
Inch	.50 NPTF	.25 NPTF	YPY		YPY/S	
Inch	.75 NPTF	.25 NPTF	YPX		YPX/S	
Inch	SAE-8	SAE-6	YPW		YPW/S	
Inch	SAE-10	SAE-6	YPV		YPV/S	
Inch	SAE-12	SAE-6	YPT		YPT/S	
Metric	.375 BSPP	.25 BSPP	YPP		YPP/S	
Metric	.50 BSPP	.25 BSPP	YPM		YPM/S	
Metric	.75 BSPP	.25 BSPP	YPQ		YPQ/S	

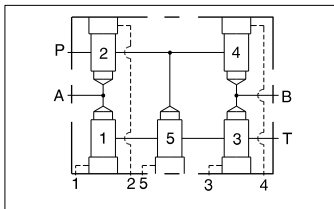

Five cavity four-way logic body for directional applications.

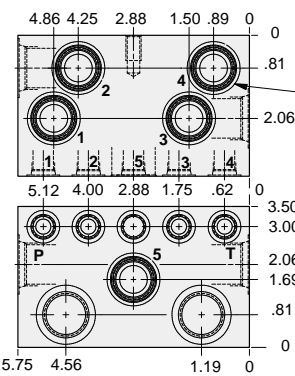

T-2A Cavity
Locating Shoulder
Depth .72
5 places.

Mounting Holes:
Inch: .375-16 UNC-2B
x .62 deep.
Metric: M10 x 1.50-6H
x .62 deep.
2 places.

TYPICAL CARTRIDGES USED WITH THIS BODY

- LOFC - *** Page 9.08
LKFC - *** Page 9.10
LPFC - *** Page 9.12
LRFC - *** Page 9.14

Instructions for ordering complete cartridge and body assemblies. Page v

Pressure ratings, material specifications. Page 11.02

Mounting Hole Dimensions	Ports A & B P & T	Ports 1, 2, 3, 4, & 5	ALUMINUM		DUCTILE IRON	
			Part Number	List Price	Part Number	List Price
Inch	.375 NPTF	.25 NPTF	YPO		YPO/S	
Inch	.50 NPTF	.25 NPTF	YPN		YPN/S	
Inch	.75 NPTF	.25 NPTF	YPS		YPS/S	
Inch	SAE-8	SAE-6	YPL		YPL/S	
Inch	SAE-10	SAE-6	YPK		YPK/S	
Inch	SAE-12	SAE-6	YPJ		YPJ/S	
Metric	.375 BSPP	.25 BSPP	YPH		YPH/S	
Metric	.50 BSPP	.25 BSPP	YPG		YPG/S	
Metric	.75 BSPP	.25 BSPP	YPF		YPF/S	



LINE MOUNT BODIES



- Aluminum rated to 3000 psi.
- Ductile Iron rated to 5000 psi.

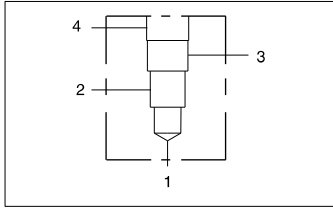

90 degree body.

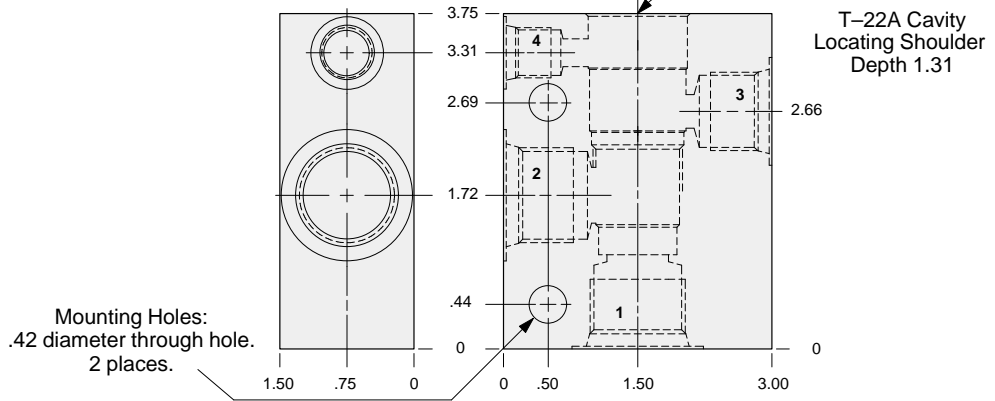

S2
T22A

TYPICAL CARTRIDGES USED WITH THIS BODY

RVED - ***	Page 1.20
PVFA - ***	Page 3.14
PVFB - ***	Page 3.16
CWEA - ***	Page 4.18
CWEG - ***	Page 4.20
CVEV - ***	Page 4.22
FVDA - ***	Page 6.04
DPCM - ***	Page 8.10
DPCN - ***	Page 8.11
DPCO - ***	Page 8.12
DPCP - ***	Page 8.13

Instructions for ordering complete cartridge and body assemblies. Page v

Pressure ratings, material specifications. Page 11.02

Ports 1 & 2	Port 3	Port 4	ALUMINUM		DUCTILE IRON	
			Part Number	List Price	Part Number	List Price
.375 NPTF	.375 NPTF	.25 NPTF	NAB		NAB/S	
.50 NPTF	.50 NPTF	.25 NPTF	NAC		NAC/S	
.75 NPTF	.50 NPTF	.25 NPTF	NAD		NAD/S	
SAE-8	SAE-8	SAE-6	NAJ		NAJ/S	
SAE-10	SAE-10	SAE-6	NAK		NAK/S	
SAE-12	SAE-10	SAE-6	NAL		NAL/S	
.375 BSPP	.375 BSPP	.25 BSPP	NAU		NAU/S	
.50 BSPP	.50 BSPP	.25 BSPP	NAV		NAV/S	
.75 BSPP	.50 BSPP	.25 BSPP	NAW		NAW/S	

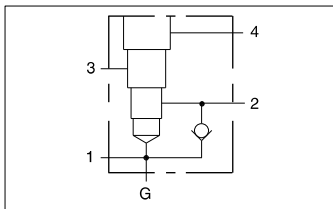

Body with reverse free flow check and gage port.

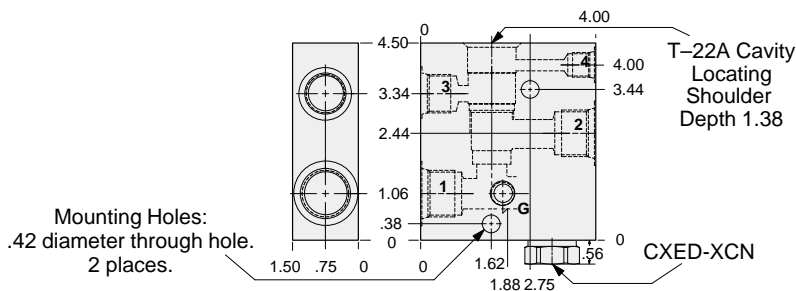

TYPICAL CARTRIDGES USED WITH THIS BODY

PVFA - ***	Page 3.14
PVFB - ***	Page 3.16

Cartridge seal type determines check valve seal type.

Instructions for ordering complete cartridge and body assemblies. Page v

Pressure ratings, material specifications. Page 11.02

Ports 1 & 2	Port 3	Port 4	Gage Port	ALUMINUM		DUCTILE IRON	
				Part Number	List Price	Part Number	List Price
.25 NPTF	.25 NPTF	.25 NPTF	.25 NPTF	N4A		N4A/S	
.375 NPTF	.375 NPTF	.25 NPTF	.25 NPTF	N4B		N4B/S	
.50 NPTF	.50 NPTF	.25 NPTF	.25 NPTF	N4C		N4C/S	
.75 NPTF	.50 NPTF	.25 NPTF	.25 NPTF	N4D		N4D/S	
SAE-6	SAE-6	SAE-6	.25 NPTF	N4I		N4I/S	
SAE-8	SAE-8	SAE-6	.25 NPTF	N4J		N4J/S	
SAE-10	SAE-10	SAE-6	.25 NPTF	N4K		N4K/S	
SAE-12	SAE-10	SAE-6	.25 NPTF	N4L		N4L/S	
.25 BSPP	.25 BSPP	.25 BSPP	.25 BSPP	N4T		N4T/S	
.375 BSPP	.375 BSPP	.25 BSPP	.25 BSPP	N4U		N4U/S	
.50 BSPP	.50 BSPP	.25 BSPP	.25 BSPP	N4V		N4V/S	
.75 BSPP	.50 BSPP	.25 BSPP	.25 BSPP	N4W		N4W/S	



LINE MOUNT BODIES



- Aluminum rated to 3000 psi.
- Ductile Iron rated to 5000 psi.

S2
T22A

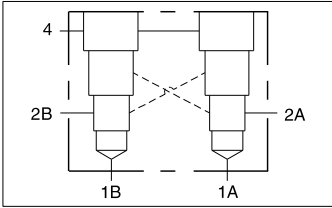

Two cavity 90 degree cross-piloted body with common port 4 for load control applications.

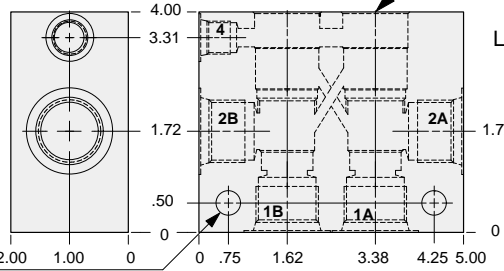

Mounting Holes:
.42 diameter through hole.
2 places.

**TYPICAL CARTRIDGES
USED WITH THIS BODY**

- CWEA - *** Page 4.18
CWEG - *** Page 4.20
CVEV - *** Page 4.22

Instructions for ordering complete cartridge and body assemblies. Page v

Pressure ratings, material specifications. Page 11.02

Ports 1A, 1B 2A & 2B	Port 4	ALUMINUM		DUCTILE IRON	
		Part Number	List Price	Part Number	List Price
.25 NPTF	.25 NPTF	XIA		XIA/S	
.375 NPTF	.25 NPTF	XIB		XIB/S	
.50 NPTF	.25 NPTF	XIC		XIC/S	
.75 NPTF	.25 NPTF	XID		XID/S	
SAE-6	SAE-6	XII		XII/S	
SAE-8	SAE-6	XIJ		XIJ/S	
SAE-10	SAE-6	XIK		XIK/S	
SAE-12	SAE-6	XIL		XIL/S	
.25 BSPP	.25 BSPP	XIT		XIT/S	
.375 BSPP	.25 BSPP	XIU		XIU/S	
.50 BSPP	.25 BSPP	XIV		XIV/S	
.75 BSPP	.25 BSPP	XIW		XIW/S	

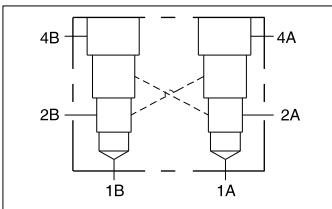

Two cavity 90 degree cross-piloted body with independent port 4 for load control applications.

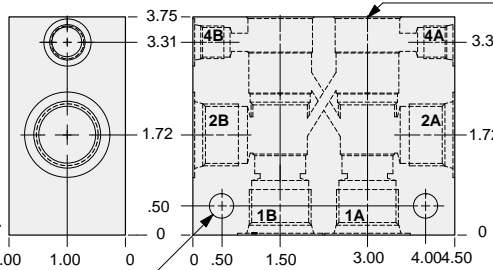

Mounting Holes:
.42 diameter through hole.
2 places.

**TYPICAL CARTRIDGES
USED WITH THIS BODY**

- CWEA - *** Page 4.18
CWEG - *** Page 4.20
CVEV - *** Page 4.22

Instructions for ordering complete cartridge and body assemblies. Page v

Pressure ratings, material specifications. Page 11.02

Ports 1A, 1B 2A & 2B	PortS 4A & 4B	ALUMINUM		DUCTILE IRON	
		Part Number	List Price	Part Number	List Price
.25 NPTF	.25 NPTF	XRA		XRA/S	
.375 NPTF	.25 NPTF	XRB		XRB/S	
.50 NPTF	.25 NPTF	XRC		XRC/S	
.75 NPTF	.25 NPTF	XRD		XRD/S	
SAE-6	SAE-6	XRI		XRI/S	
SAE-8	SAE-6	XRJ		XRJ/S	
SAE-10	SAE-6	XRK		XRK/S	
SAE-12	SAE-6	XRL		XRL/S	
.25 BSPP	.25 BSPP	XRT		XRT/S	
.375 BSPP	.25 BSPP	XRU		XRU/S	
.50 BSPP	.25 BSPP	XRV		XRV/S	
.75 BSPP	.25 BSPP	XRW		XRW/S	



LINE MOUNT BODIES

- Aluminum rated to 3000 psi.
- Ductile Iron rated to 5000 psi.



S2
T22A

Gasket mount body for load control applications.

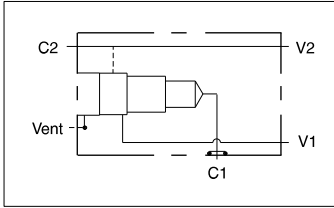

TYPICAL CARTRIDGES USED WITH THIS BODY

CWEA - *** Page 4.18
 CWEG - *** Page 4.20
 CVEV - *** Page 4.22

Cartridge seal type determines O-ring type.

Instructions for ordering complete cartridge and body assemblies. Page v

Pressure ratings, material specifications. Page 11.02

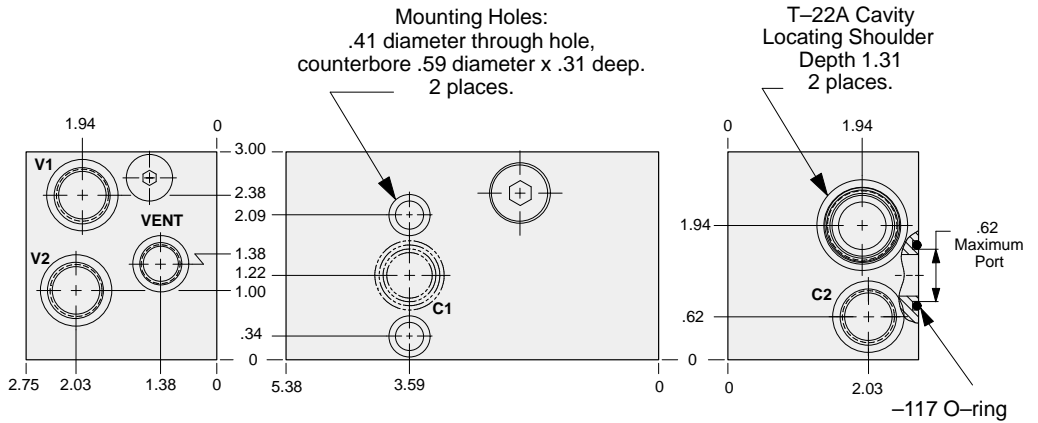

Ports C2, V1, & V2	Vent Port	ALUMINUM		DUCTILE IRON	
		Part Number	List Price	Part Number	List Price
.50 NPTF	.25 NPTF	WJB		WJB/S	
SAE-8	SAE-6	WJC		WJC/S	
.50 BSPP	.25 BSPP	WJD		WJD/S	

Two cavity gasket mount dual load control body.

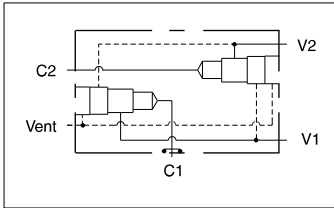

TYPICAL CARTRIDGES USED WITH THIS BODY

CWEA - *** Page 4.18
 CWEG - *** Page 4.20
 CVEV - *** Page 4.22

Cartridge seal type determines O-ring type.

Instructions for ordering complete cartridge and body assemblies. Page v

Pressure ratings, material specifications. Page 11.02

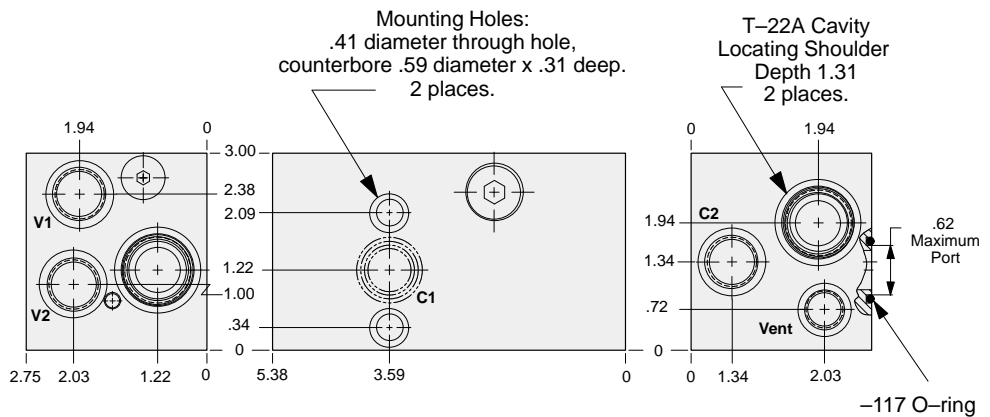

Ports C2, V1, & V2	Vent Port	ALUMINUM		DUCTILE IRON	
		Part Number	List Price	Part Number	List Price
.50 NPTF	.25 NPTF	VZN		VZN/S	
SAE-8	SAE-6	VZO		VZO/S	
.50 BSPP	.25 BSPP	VZP		VZP/S	



LINE MOUNT BODIES



- Aluminum rated to 3000 psi.
- Ductile Iron rated to 5000 psi.

S2
T32A

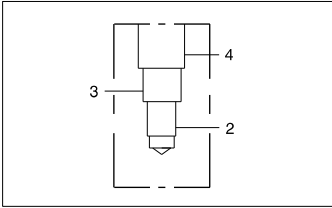

Body for flow divider/combiner applications.

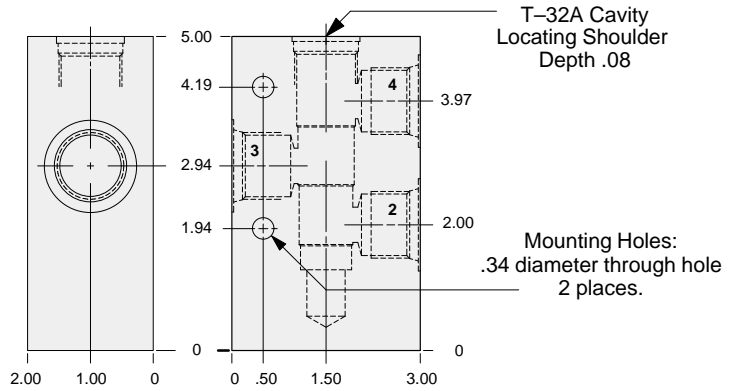

TYPICAL CARTRIDGES USED WITH THIS BODY

- FSDD - *** Page 7.08
 FSDA - *** Page 7.10
 FSDS - *** Page 7.12
 FSDH - *** Page 7.14

Instructions for ordering complete cartridge and body assemblies. Page v

Pressure ratings, material specifications. Page 11.02

Ports 2, 3, & 4	ALUMINUM		DUCTILE IRON	
	Part Number	List Price	Part Number	List Price
.375 NPTF	NMB		NMB/S	
.50 NPTF	NMC		NMC/S	
.75 NPTF	NMD		NMD/S	
SAE-8	NMJ		NMJ/S	
SAE-10	NMK		NMK/S	
SAE-12	NML		NML/S	
.375 BSPP	NMU		NMU/S	
.50 BSPP	NMV		NMV/S	
.75 BSPP	NMW		NMW/S	

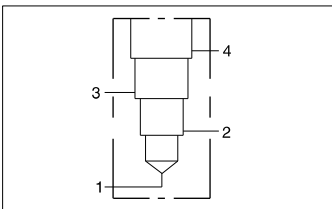

Four port body.

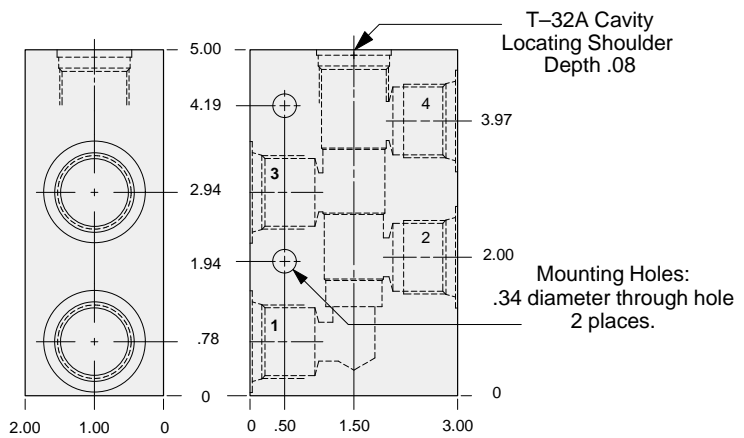

Instructions for ordering complete cartridge and body assemblies. Page v

Pressure ratings, material specifications. Page 11.02

Ports 1, 2, 3, 4, & 5	ALUMINUM		DUCTILE IRON	
	Part Number	List Price	Part Number	List Price
.375 NPTF	NNB		NNB/S	
.50 NPTF	NNC		NNC/S	
.75 NPTF	NND		NND/S	
SAE-8	NNJ		NNJ/S	
SAE-10	NNK		NNK/S	
SAE-12	NNL		NNL/S	
.375 BSPP	NNU		NNU/S	
.50 BSPP	NNV		NNV/S	
.75 BSPP	NNW		NNW/S	



LINE MOUNT BODIES



- Aluminum rated to 3000 psi.
- Ductile Iron rated to 5000 psi.

90 degree body with gage port.

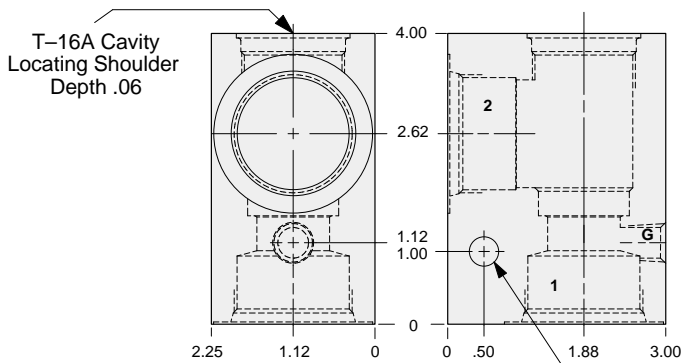
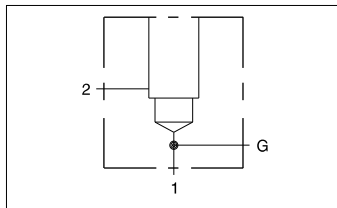

Mounting Holes:
.42 diameter
through hole.

S3
T16A

TYPICAL CARTRIDGES USED WITH THIS BODY

RPIC - ***	Page 1.07
RPIE - ***	Page 1.09
RDHA - ***	Page 1.11
RQIB - ***	Page 1.13
RPID - ***	Page 1.15
CXHA - ***	Page 5.09
CXGD - ***	Page 5.11
NFEC - ***	Page 5.13
CNGC - ***	Page 5.15
NCFB - ***	Page 5.17
NCFC - ***	Page 5.19
FXEA - ***	Page 5.21
FCEB - ***	Page 5.23
FDEA - ***	Page 5.25
FQGA - ***	Page 10.15

Instructions for ordering complete cartridge and body assemblies. Page v

Pressure ratings, material specifications. Page 11.02

Ports 1 & 2	Gage Port	ALUMINUM		DUCTILE IRON	
		Part Number	List Price	Part Number	List Price
.75 NPTF	.25 NPTF	IAD		IAD/S	
1.00 NPTF	.25 NPTF	IAE		IAE/S	
1.25 NPTF	.25 NPTF	IAF		IAF/S	
SAE-12	.25 NPTF	IAL		IAL/S	
SAE-16	.25 NPTF	IAM		IAM/S	
SAE-20	.25 NPTF	IAN		IAN/S	
.75 BSPP	.25 BSPP	IAW		IAW/S	
1.00 BSPP	.25 BSPP	IAX		IAX/S	
1.25 BSPP	.25 BSPP	IAY		IAY/S	

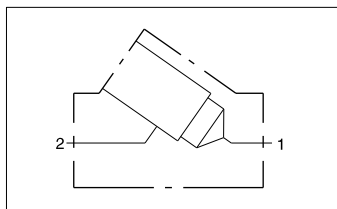

Inline body.

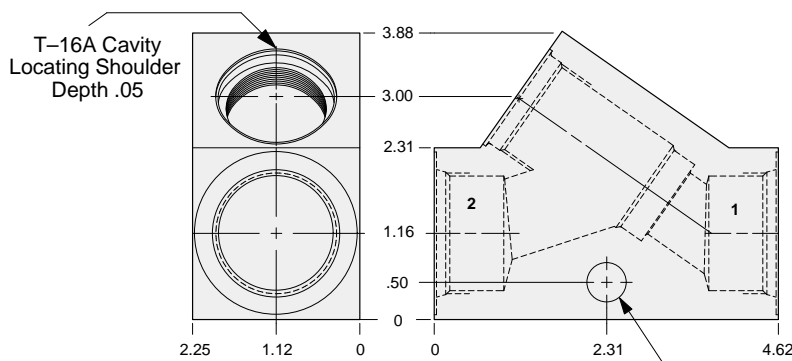

Mounting Holes:
.53 diameter
through hole.

TYPICAL CARTRIDGES USED WITH THIS BODY

RPIC - ***	Page 1.07
RPIE - ***	Page 1.09
RDHA - ***	Page 1.11
RQIB - ***	Page 1.13
RPID - ***	Page 1.15
CXHA - ***	Page 5.09
CXGD - ***	Page 5.11
NFEC - ***	Page 5.13
CNGC - ***	Page 5.15
NCFB - ***	Page 5.17
NCFC - ***	Page 5.19
FXEA - ***	Page 5.21
FCEB - ***	Page 5.23
FDEA - ***	Page 5.25
FQGA - ***	Page 10.15

Instructions for ordering complete cartridge and body assemblies. Page v

Pressure ratings, material specifications. Page 11.02

Ports 1 & 2	ALUMINUM		DUCTILE IRON	
	Part Number	List Price	Part Number	List Price
.75 NPTF	ICD		ICD/S	
1.00 NPTF	ICE		ICE/S	
1.25 NPTF	ICF		ICF/S	
SAE-12	ICL		ICL/S	
SAE-16	ICM		ICM/S	
SAE-20	ICN		ICN/S	
.75 BSPP	ICW		ICW/S	
1.00 BSPP	ICX		ICX/S	
1.25 BSPP	ICY		ICY/S	



LINE MOUNT BODIES



- Aluminum rated to 3000 psi.
- Ductile Iron rated to 5000 psi.

Inline 1.00" SAE Code 61 flange port body.

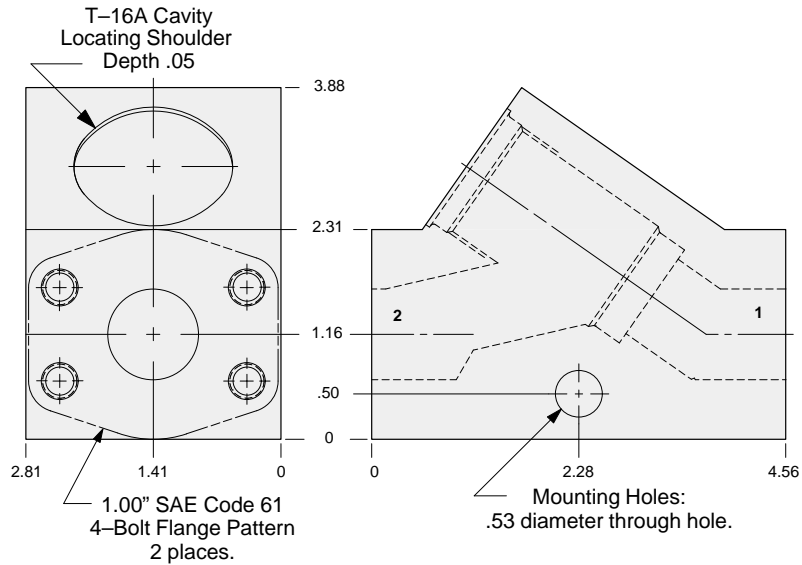
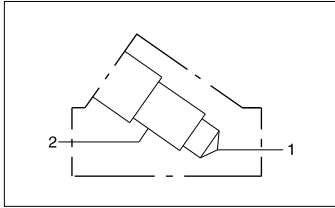

Mounting Hole Dimensions	ALUMINUM		DUCTILE IRON	
	Part Number	List Price	Part Number	List Price
Inch	ICP		ICP/S	
Metric	ICP/M		ICP/T	

TYPICAL CARTRIDGES USED WITH THIS BODY

RPIC - ***	Page 1.07
RPIE - ***	Page 1.09
RDHA - ***	Page 1.11
RQIB - ***	Page 1.13
RPID - ***	Page 1.15
CXHA - ***	Page 5.09
CXGD - ***	Page 5.11
NFEC - ***	Page 5.13
CNGC - ***	Page 5.15
NCFB - ***	Page 5.17
NCFC - ***	Page 5.19
FXEA - ***	Page 5.21
FCEB - ***	Page 5.23
FDEA - ***	Page 5.25
FQGA - ***	Page 10.15

Instructions for ordering complete cartridge and body assemblies. Page v

Pressure ratings, material specifications. Page 11.02

SAE Specifications Page 11.03

Through port body with gage port.

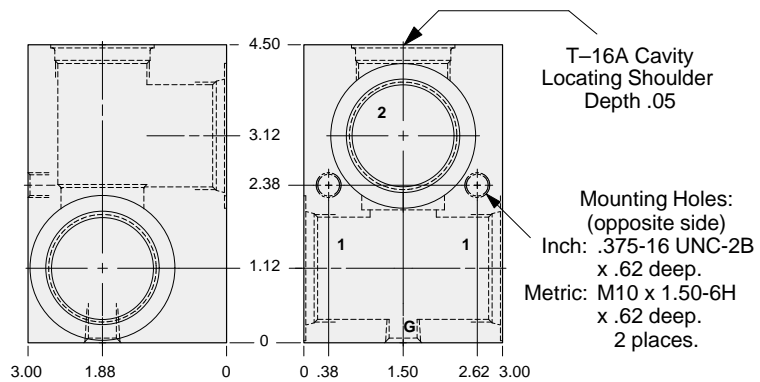
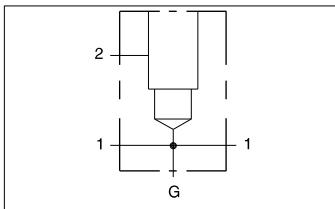

TYPICAL CARTRIDGES USED WITH THIS BODY

RPIC - ***	Page 1.07
RPIE - ***	Page 1.09
RDHA - ***	Page 1.11
RQIB - ***	Page 1.13
RPID - ***	Page 1.15
NFEC - ***	Page 5.13
CNGC - ***	Page 5.15
NCFB - ***	Page 5.17
NCFC - ***	Page 5.19
FXEA - ***	Page 5.21
FCEB - ***	Page 5.23
FDEA - ***	Page 5.25

Instructions for ordering complete cartridge and body assemblies. Page v

Pressure ratings, material specifications. Page 11.02

Mounting Hole Dimensions	Ports 1 & 2	Gage Port	ALUMINUM		DUCTILE IRON	
			Part Number	List Price	Part Number	List Price
Inch	.75 NPTF	.25 NPTF	IED		IED/S	
Inch	1.00 NPTF	.25 NPTF	IEE		IEE/S	
Inch	1.25 NPTF	.25 NPTF	IEF		IEF/S	
Inch	SAE-12	.25 NPTF	IEL		IEL/S	
Inch	SAE-16	.25 NPTF	IEM		IEM/S	
Inch	SAE-20	.25 NPTF	IEN		IEN/S	
Metric	.75 BSPP	.25 BSPP	IEW		IEW/S	
Metric	1.00 BSPP	.25 BSPP	IEX		IEX/S	
Metric	1.25 BSPP	.25 BSPP	IEY		IEY/S	



LINE MOUNT BODIES

- Aluminum rated to 3000 psi.
- Ductile Iron rated to 5000 psi.

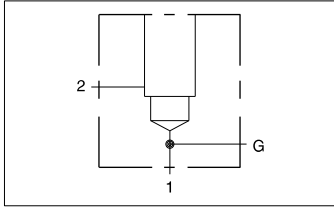

90 degree 1.00" SAE Code 61 flange port body with gage port.

TYPICAL CARTRIDGES USED WITH THIS BODY

RPIC - ***	Page 1.07
RPIE - ***	Page 1.09
RDHA - ***	Page 1.11
RQIB - ***	Page 1.13
RPID - ***	Page 1.15
CXHA - ***	Page 5.09
CXGD - ***	Page 5.11
NFEC - ***	Page 5.13
CNGC - ***	Page 5.15
NCFB - ***	Page 5.17
NCFC - ***	Page 5.19
FXEA - ***	Page 5.21
FCEB - ***	Page 5.23
FDEA - ***	Page 5.25
FQGA - ***	Page 10.15

Instructions for ordering complete cartridge and body assemblies. Page v

Pressure ratings, material specifications. Page 11.02

SAE Specifications Page 11.03

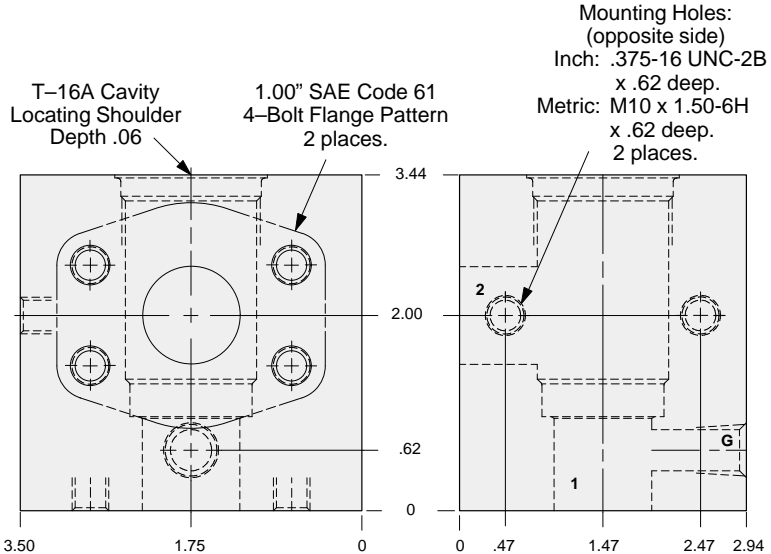

Mounting Hole Dimensions	Gage Port	ALUMINUM		DUCTILE IRON	
		Part Number	List Price	Part Number	List Price
Inch	.25 NPTF	IAP		IAP/S	
Metric	.25 BSPP	IAP/M		IAP/T	

S3
T16A

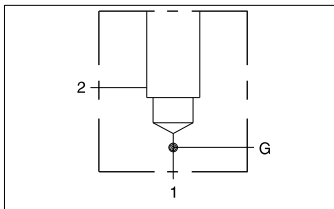

90 degree 1.00" SAE Code 62 flange port body with gage port.

TYPICAL CARTRIDGES USED WITH THIS BODY

RPIC - ***	Page 1.07
RPIE - ***	Page 1.09
RDHA - ***	Page 1.11
RQIB - ***	Page 1.13
RPID - ***	Page 1.15
CXHA - ***	Page 5.09
CXGD - ***	Page 5.11
NFEC - ***	Page 5.13
CNGC - ***	Page 5.15
NCFB - ***	Page 5.17
NCFC - ***	Page 5.19
FXEA - ***	Page 5.21
FCEB - ***	Page 5.23
FDEA - ***	Page 5.25
FQGA - ***	Page 10.15

Instructions for ordering complete cartridge and body assemblies. Page v

Pressure ratings, material specifications. Page 11.02

SAE Specifications Page 11.03

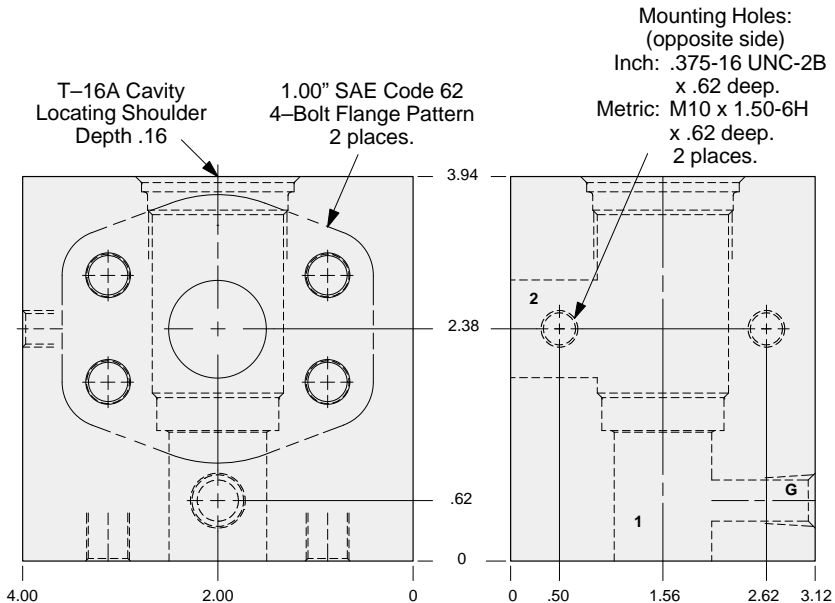

Mounting Hole Dimensions	Gage Port	ALUMINUM		DUCTILE IRON	
		Part Number	List Price	Part Number	List Price
Inch	.25 NPTF	IA4		IA4/S	
Metric	.25 BSPP	IA4/M		IA4/T	



LINE MOUNT BODIES



- Aluminum rated to 3000 psi.
- Ductile Iron rated to 5000 psi.

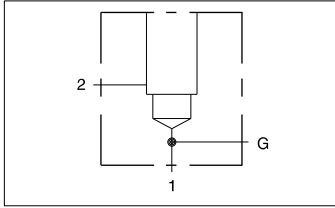

90 degree 1.25" SAE Code 61 flange port body with gage port.

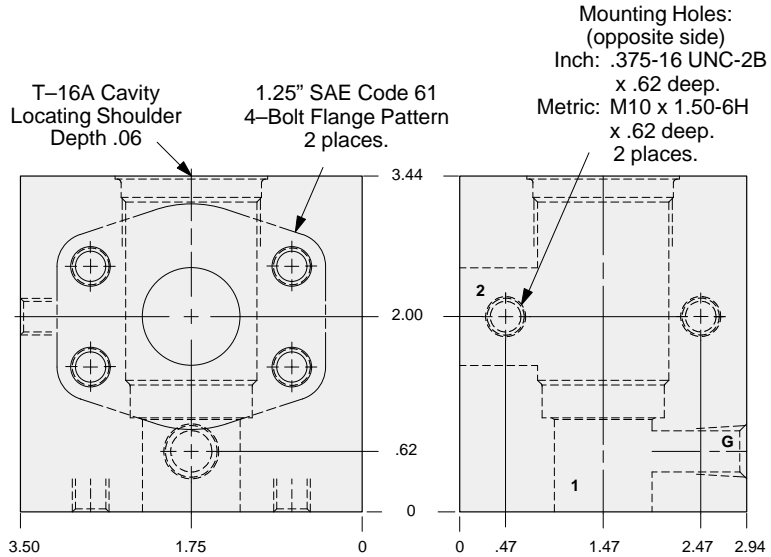

S3
T16A

TYPICAL CARTRIDGES USED WITH THIS BODY

RPIC - ***	Page 1.07
RPIE - ***	Page 1.09
RDHA - ***	Page 1.11
RQIB - ***	Page 1.13
RPID - ***	Page 1.15
CXHA - ***	Page 5.09
CXGD - ***	Page 5.11
NFEC - ***	Page 5.13
CNGC - ***	Page 5.15
NCFB - ***	Page 5.17
NCFC - ***	Page 5.19
FXEA - ***	Page 5.21
FCEB - ***	Page 5.23
FDEA - ***	Page 5.25
FQGA - ***	Page 10.15

Instructions for ordering complete cartridge and body assemblies. Page v

Pressure ratings, material specifications. Page 11.02

SAE Specifications Page 11.03

Mounting Hole Dimensions	Gage Port	ALUMINUM		DUCTILE IRON	
		Part Number	List Price	Part Number	List Price
Inch	.25 NPTF	IAQ		IAQ/S	
Metric	.25 BSPP	IAQ/M		IAQ/T	

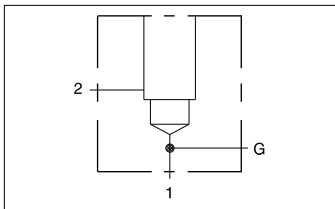

90 degree 1.25" SAE Code 62 flange port body with gage port.

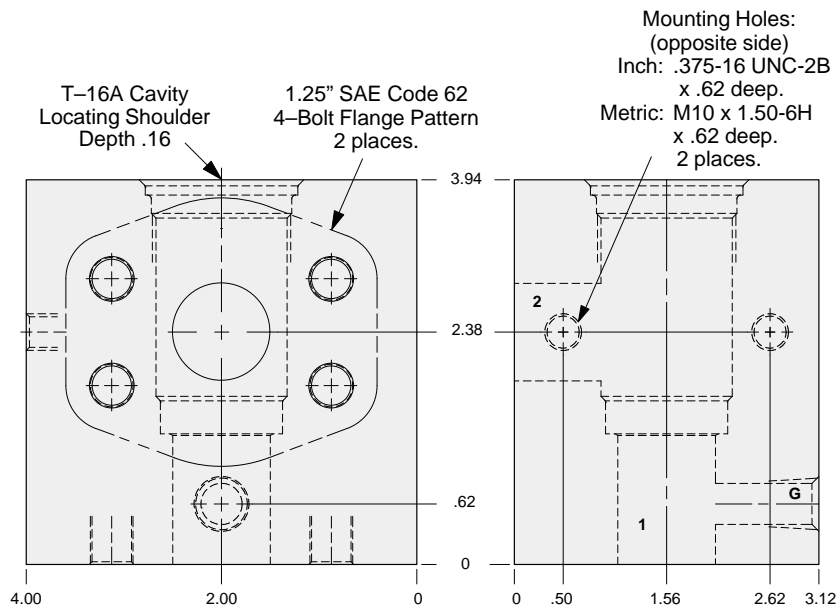

TYPICAL CARTRIDGES USED WITH THIS BODY

RPIC - ***	Page 1.07
RPIE - ***	Page 1.09
RDHA - ***	Page 1.11
RQIB - ***	Page 1.13
RPID - ***	Page 1.15
CXHA - ***	Page 5.09
CXGD - ***	Page 5.11
NFEC - ***	Page 5.13
CNGC - ***	Page 5.15
NCFB - ***	Page 5.17
NCFC - ***	Page 5.19
FXEA - ***	Page 5.21
FCEB - ***	Page 5.23
FDEA - ***	Page 5.25
FQGA - ***	Page 10.15

Instructions for ordering complete cartridge and body assemblies. Page v

Pressure ratings, material specifications. Page 11.02

SAE Specifications Page 11.03

Mounting Hole Dimensions	Gage Port	ALUMINUM		DUCTILE IRON	
		Part Number	List Price	Part Number	List Price
Inch	.25 NPTF	IA5		IA5/S	
Metric	.25 BSPP	IA5/M		IA5/T	



LINE MOUNT BODIES



- Aluminum rated to 3000 psi.
- Ductile Iron rated to 5000 psi.

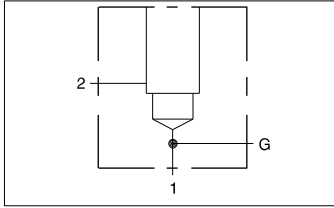

90 degree 1.50" SAE Code 61 flange port body with gage port.

TYPICAL CARTRIDGES USED WITH THIS BODY

RPIC - ***	Page 1.07
RPIE - ***	Page 1.09
RDHA - ***	Page 1.11
RQIB - ***	Page 1.13
RPID - ***	Page 1.15
CXHA - ***	Page 5.09
CXGD - ***	Page 5.11
NFEC - ***	Page 5.13
CNGC - ***	Page 5.15
NCFB - ***	Page 5.17
NCFC - ***	Page 5.19
FXEA - ***	Page 5.21
FCEB - ***	Page 5.23
FDEA - ***	Page 5.25
FQGA - ***	Page 10.15

Instructions for ordering complete cartridge and body assemblies. Page v

Pressure ratings, material specifications. Page 11.02

SAE Specifications Page 11.03

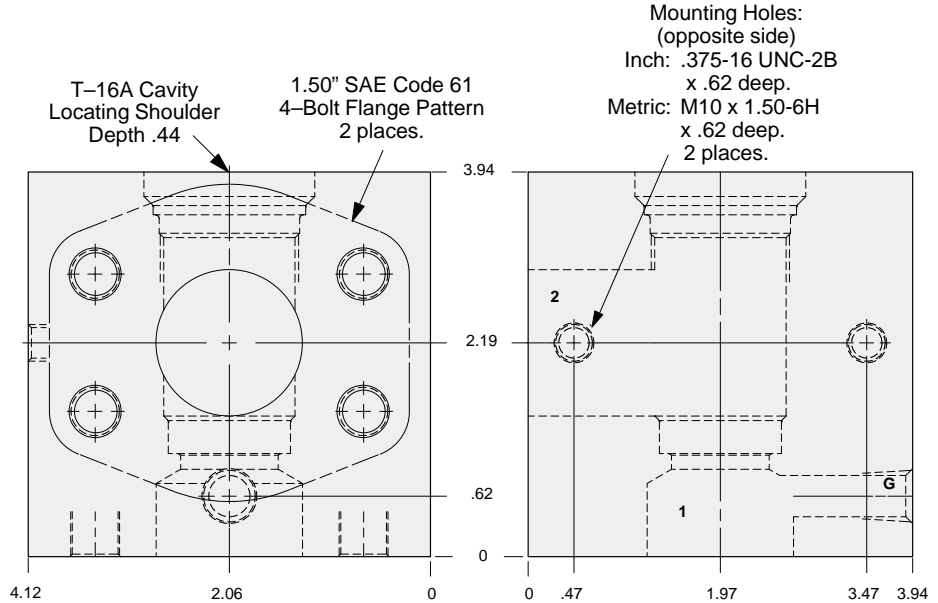

Mounting Hole Dimensions	Gage Port	ALUMINUM		DUCTILE IRON	
		Part Number	List Price	Part Number	List Price
Inch	.25 NPTF	IAR		IAR/S	
Metric	.25 BSPP	IAR/M		IAR/T	

S3
T16A

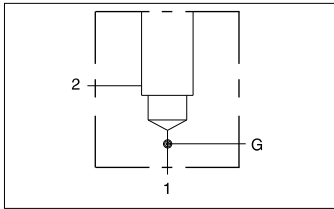

90 degree 1.50" SAE Code 62 flange port body with gage port.

TYPICAL CARTRIDGES USED WITH THIS BODY

RPIC - ***	Page 1.07
RPIE - ***	Page 1.09
RDHA - ***	Page 1.11
RQIB - ***	Page 1.13
RPID - ***	Page 1.15
CXHA - ***	Page 5.09
CXGD - ***	Page 5.11
NFEC - ***	Page 5.13
CNGC - ***	Page 5.15
NCFB - ***	Page 5.19
NCFC - ***	Page 5.19
FXEA - ***	Page 5.21
FCEB - ***	Page 5.23
FDEA - ***	Page 5.25
FQGA - ***	Page 10.15

Instructions for ordering complete cartridge and body assemblies. Page v

Pressure ratings, material specifications. Page 11.02

SAE Specifications Page 11.03

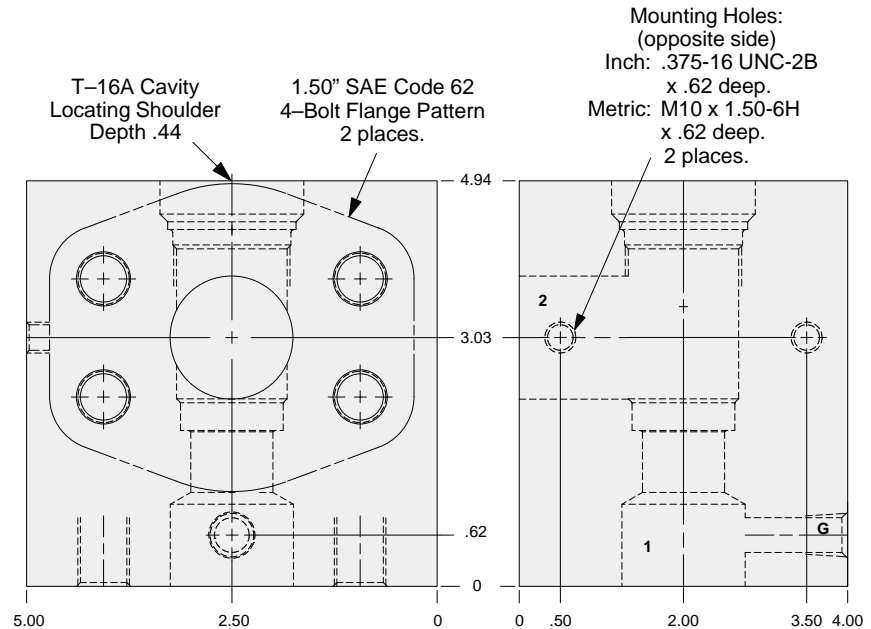

Mounting Hole Dimensions	Gage Port	ALUMINUM		DUCTILE IRON	
		Part Number	List Price	Part Number	List Price
Inch	.25 NPTF	IA6		IA6/S	
Metric	.25 BSPP	IA6/M		IA6/T	





LINE MOUNT BODIES



- Aluminum rated to 3000 psi.
- Ductile Iron rated to 5000 psi.

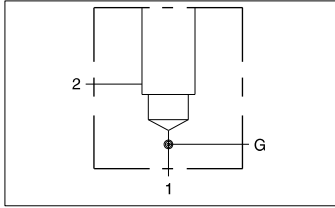

90 degree 2.00" SAE Code 61 flange port body with gage port.

TYPICAL CARTRIDGES USED WITH THIS BODY

RPIC - ***	Page 1.07
RPIE - ***	Page 1.09
RDHA - ***	Page 1.11
RQIB - ***	Page 1.13
RPID - ***	Page 1.15
CXHA - ***	Page 5.09
CXGD - ***	Page 5.11
NFEC - ***	Page 5.13
CNGC - ***	Page 5.15
NCGB - ***	Page 5.17
NCFB - ***	Page 5.19
FXEA - ***	Page 5.21
FCEB - ***	Page 5.23
FDEA - ***	Page 5.25
FQGA - ***	Page 10.15

Instructions for ordering complete cartridge and body assemblies. Page v

Pressure ratings, material specifications. Page 11.02

SAE Specifications Page 11.03

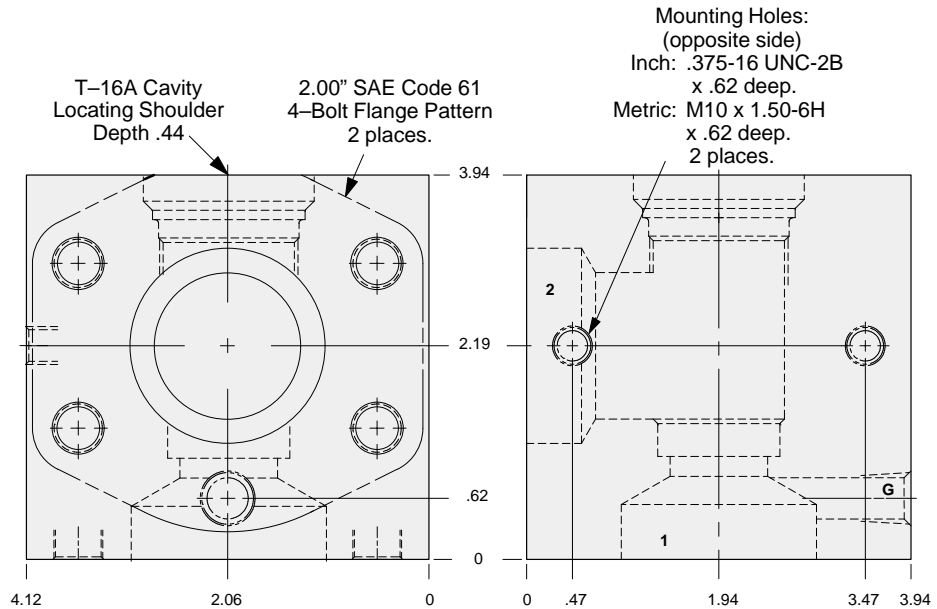

Mounting Hole Dimensions	Gage Port	ALUMINUM		DUCTILE IRON	
		Part Number	List Price	Part Number	List Price
Inch	.25 NPTF	IAS		IAS/S	
Metric	.25 BSPP	IAS/M		IAS/T	

S3
T16A

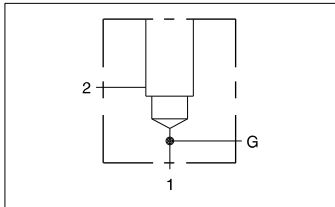

90 degree 2.00" SAE Code 62 flange port body with gage port.

TYPICAL CARTRIDGES USED WITH THIS BODY

RPIC - ***	Page 1.07
RPIE - ***	Page 1.09
RDHA - ***	Page 1.11
RQIB - ***	Page 1.13
RPID - ***	Page 1.15
CXHA - ***	Page 5.09
CXGD - ***	Page 5.11
NFEC - ***	Page 5.13
CNGC - ***	Page 5.15
NCGB - ***	Page 5.17
NCFB - ***	Page 5.19
FXEA - ***	Page 5.21
FCEB - ***	Page 5.23
FDEA - ***	Page 5.25
FQGA - ***	Page 10.15

Instructions for ordering complete cartridge and body assemblies. Page v

Pressure ratings, material specifications. Page 11.02

SAE Specifications Page 11.03

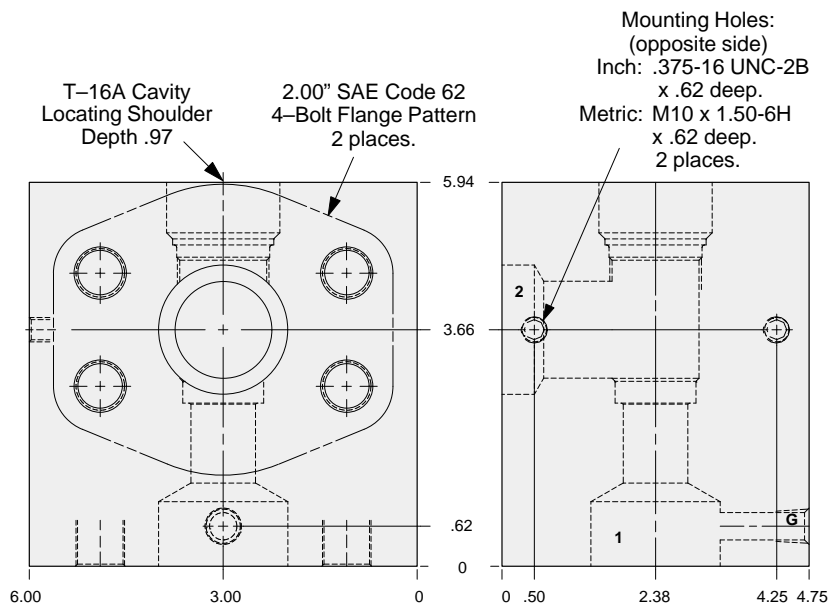

Mounting Hole Dimensions	Gage Port	ALUMINUM		DUCTILE IRON	
		Part Number	List Price	Part Number	List Price
Inch	.25 NPTF	IA8		IA8/S	
Metric	.25 BSPP	IA8/M		IA8/T	



LINE MOUNT BODIES



- Aluminum rated to 3000 psi.
- Ductile Iron rated to 5000 psi.

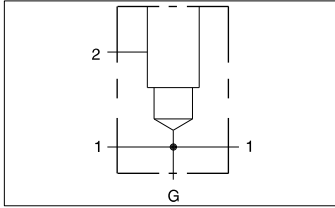

Through port 1.00" SAE Code 61 flange port body with gage port.

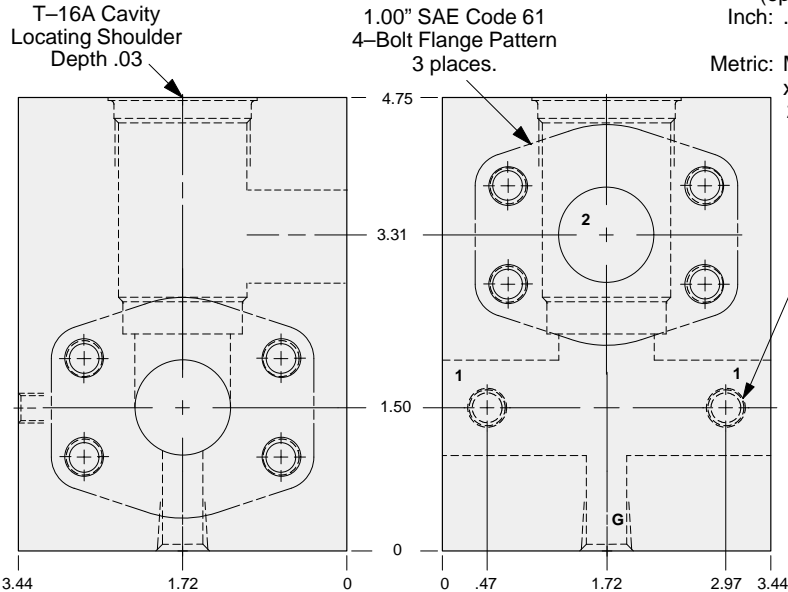

Mounting Holes:
(opposite side)
Inch: .375-16 UNC-2B
x .75 deep.
Metric: M10 x 1.50-6H
x .75 deep.
2 places.

Mounting Hole Dimensions	Gage Port	ALUMINUM		DUCTILE IRON	
		Part Number	List Price	Part Number	List Price
Inch	.25 NPTF	IEP		IEP/S	
Metric	.25 BSPP	IEP/M		IEP/T	

S3
T16A

TYPICAL CARTRIDGES USED WITH THIS BODY

RPIC - ***	Page 1.07
RPIE - ***	Page 1.09
RDHA - ***	Page 1.11
RQIB - ***	Page 1.13
RPID - ***	Page 1.15
NFEC - ***	Page 5.13
CNGC - ***	Page 5.15
NCFB - ***	Page 5.17
NCFC - ***	Page 5.19
FXEA - ***	Page 5.21
FCEB - ***	Page 5.23
FDEA - ***	Page 5.25

Instructions for ordering complete cartridge and body assemblies. Page v

Pressure ratings, material specifications. Page 11.02

SAE Specifications Page 11.03

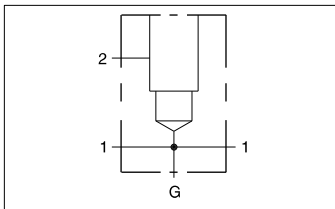

Through port 1.00" SAE Code 62 flange port body with gage port.

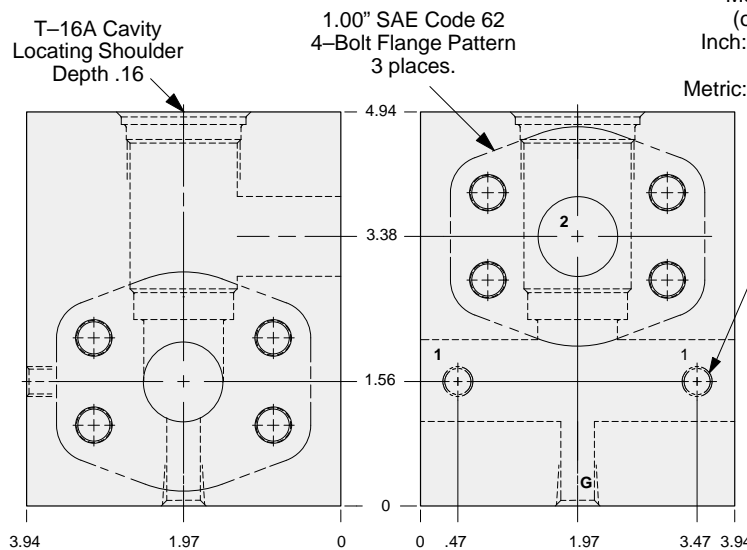

Mounting Holes:
(opposite side)
Inch: .375-16 UNC-2B
x .75 deep.
Metric: M10 x 1.50-6H
x .75 deep.
2 places.

Mounting Hole Dimensions	Gage Port	ALUMINUM		DUCTILE IRON	
		Part Number	List Price	Part Number	List Price
Inch	.25 NPTF	IE4		IE4/S	
Metric	.25 BSPP	IE4/M		IE4/T	

TYPICAL CARTRIDGES USED WITH THIS BODY

RPIC - ***	Page 1.07
RPIE - ***	Page 1.09
RDHA - ***	Page 1.11
RQIB - ***	Page 1.13
RPID - ***	Page 1.15
NFEC - ***	Page 5.13
CNGC - ***	Page 5.15
NCFB - ***	Page 5.17
NCFC - ***	Page 5.19
FXEA - ***	Page 5.21
FCEB - ***	Page 5.23
FDEA - ***	Page 5.25

Instructions for ordering complete cartridge and body assemblies. Page v

Pressure ratings, material specifications. Page 11.02

SAE Specifications Page 11.03



LINE MOUNT BODIES



- Aluminum rated to 3000 psi.
- Ductile Iron rated to 5000 psi.

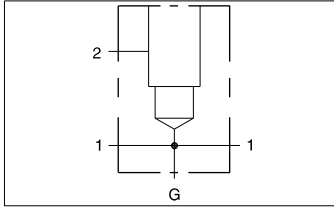

TYPICAL CARTRIDGES USED WITH THIS BODY

RPIC - ***	Page 1.07
RPIE - ***	Page 1.09
RDHA - ***	Page 1.11
RQIB - ***	Page 1.13
RPID - ***	Page 1.15
NFEC - ***	Page 5.13
CNGC - ***	Page 5.15
NCFB - ***	Page 5.17
NCFC - ***	Page 5.19
FXEA - ***	Page 5.21
FCEB - ***	Page 5.23
FDEA - ***	Page 5.25

Instructions for ordering complete cartridge and body assemblies. Page v

Pressure ratings, material specifications. Page 11.02

SAE Specifications Page 11.03

Through port 1.25" SAE Code 61 flange port body with gage port.

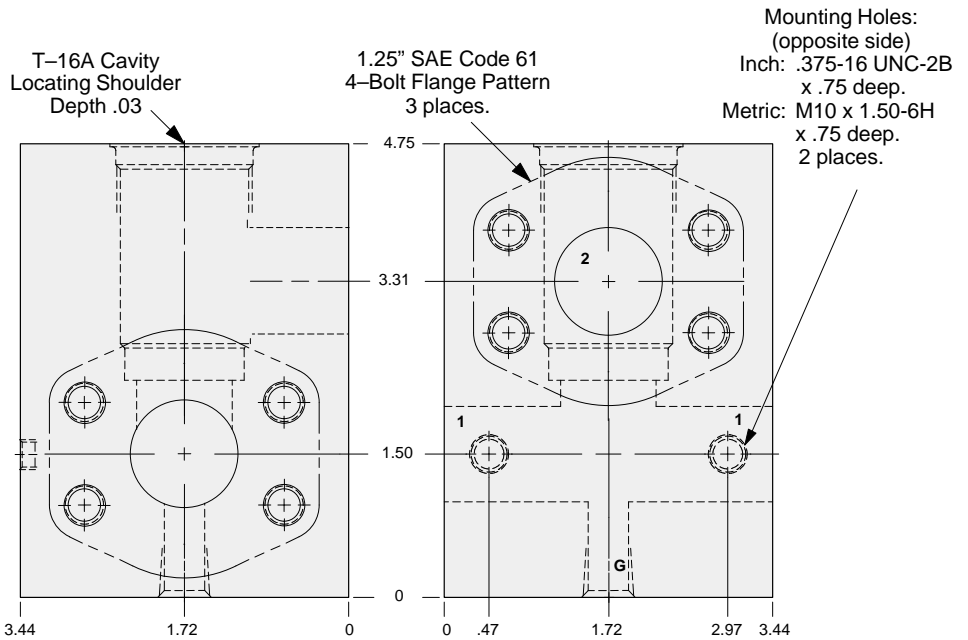

Mounting Hole Dimensions	Gage Port	ALUMINUM		DUCTILE IRON	
		Part Number	List Price	Part Number	List Price
Inch	.25 NPTF	IEQ		IEQ/S	
Metric	.25 BSPP	IEQ/M		IEQ/T	

S3
T16A

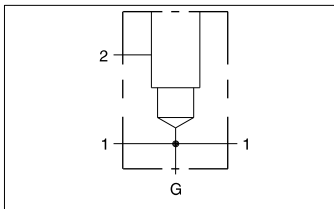

TYPICAL CARTRIDGES USED WITH THIS BODY

RPIC - ***	Page 1.07
RPIE - ***	Page 1.09
RDHA - ***	Page 1.11
RQIB - ***	Page 1.13
RPID - ***	Page 1.15
NFEC - ***	Page 5.13
CNGC - ***	Page 5.15
NCFB - ***	Page 5.17
NCFC - ***	Page 5.19
FXEA - ***	Page 5.21
FCEB - ***	Page 5.23
FDEA - ***	Page 5.25

Instructions for ordering complete cartridge and body assemblies. Page v

Pressure ratings, material specifications. Page 11.02

SAE Specifications Page 11.03

Through port 1.25" SAE Code 62 flange port body with gage port.

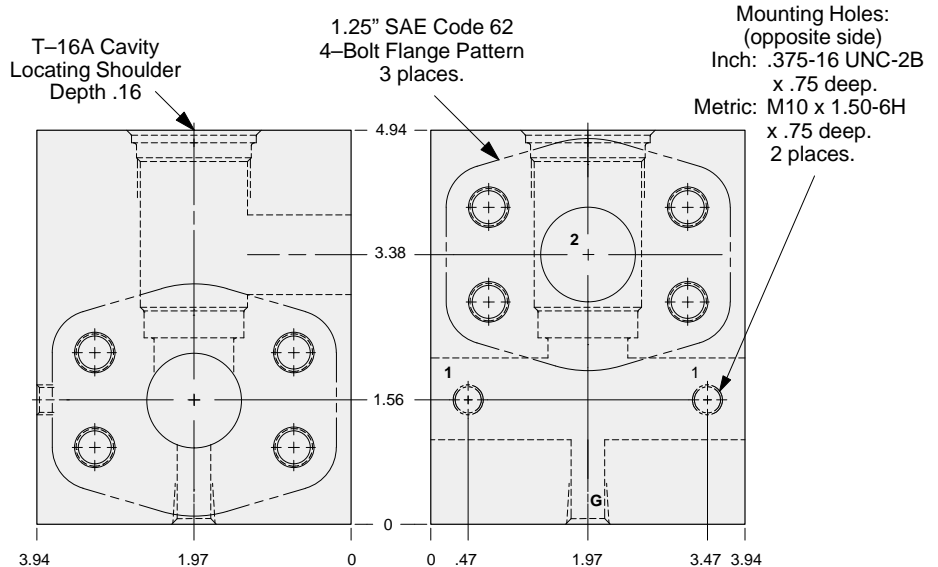

Mounting Hole Dimensions	Gage Port	ALUMINUM		DUCTILE IRON	
		Part Number	List Price	Part Number	List Price
Inch	.25 NPTF	IE5		IE5/S	
Metric	.25 BSPP	IE5/M		IE5/T	



LINE MOUNT BODIES



- Aluminum rated to 3000 psi.
- Ductile Iron rated to 5000 psi.

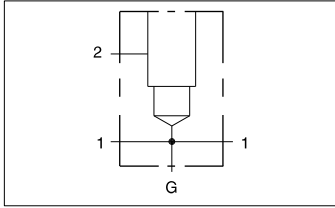

Through port 1.50" SAE Code 61 flange port body with gage port.

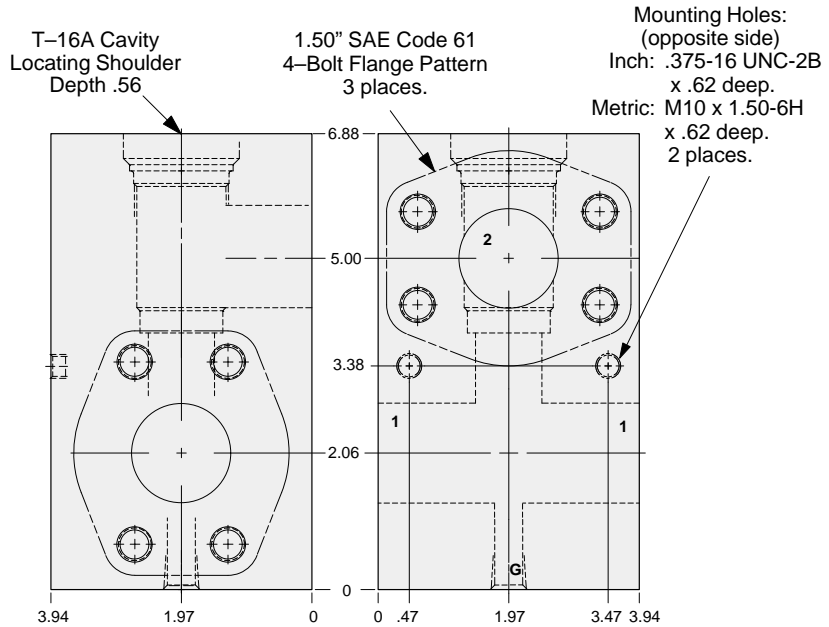

Mounting Hole Dimensions	Gage Port	ALUMINUM		DUCTILE IRON	
		Part Number	List Price	Part Number	List Price
Inch	.25 NPTF	IER		IER/S	
Metric	.25 BSPP	IER/M		IER/T	

S3
T16A

TYPICAL CARTRIDGES USED WITH THIS BODY

RPIC - ***	Page 1.07
RPIE - ***	Page 1.09
RDHA - ***	Page 1.11
RQIB - ***	Page 1.13
RPID - ***	Page 1.15
NFEC - ***	Page 5.13
CNGC - ***	Page 5.15
NCFB - ***	Page 5.17
NCFC - ***	Page 5.19
FXEA - ***	Page 5.21
FCEB - ***	Page 5.23
FDEA - ***	Page 5.25

Instructions for ordering complete cartridge and body assemblies. Page v

Pressure ratings, material specifications. Page 11.02

SAE Specifications Page 11.03

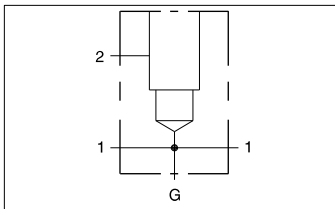

Through port 1.50" SAE Code 62 flange port body with gage port.

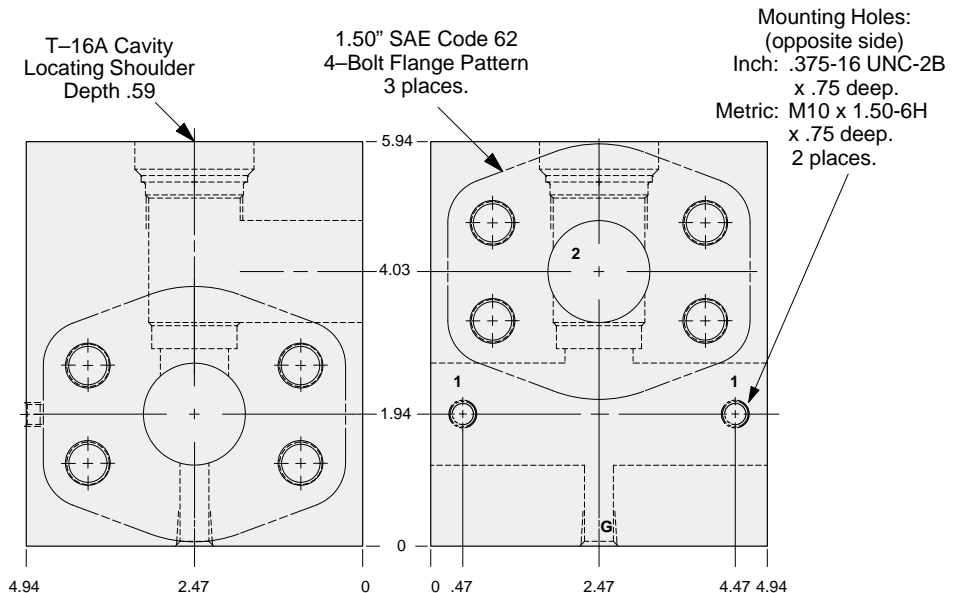

Mounting Hole Dimensions	Gage Port	ALUMINUM		DUCTILE IRON	
		Part Number	List Price	Part Number	List Price
Inch	.25 NPTF	IE6		IE6/S	
Metric	.25 BSPP	IE6/M		IE6/T	

TYPICAL CARTRIDGES USED WITH THIS BODY

RPIC - ***	Page 1.07
RPIE - ***	Page 1.09
RDHA - ***	Page 1.11
RQIB - ***	Page 1.13
RPID - ***	Page 1.15
NFEC - ***	Page 5.13
CNGC - ***	Page 5.15
NCFB - ***	Page 5.17
NCFC - ***	Page 5.19
FXEA - ***	Page 5.21
FCEB - ***	Page 5.23
FDEA - ***	Page 5.25

Instructions for ordering complete cartridge and body assemblies. Page v

Pressure ratings, material specifications. Page 11.02

SAE Specifications Page 11.03



LINE MOUNT BODIES



- Aluminum rated to 3000 psi.
- Ductile Iron rated to 5000 psi.

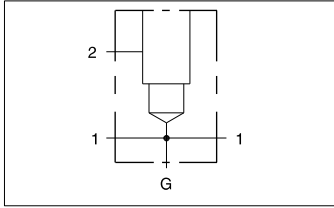

Through port 2.00" SAE Code 61 flange port body with gage port.

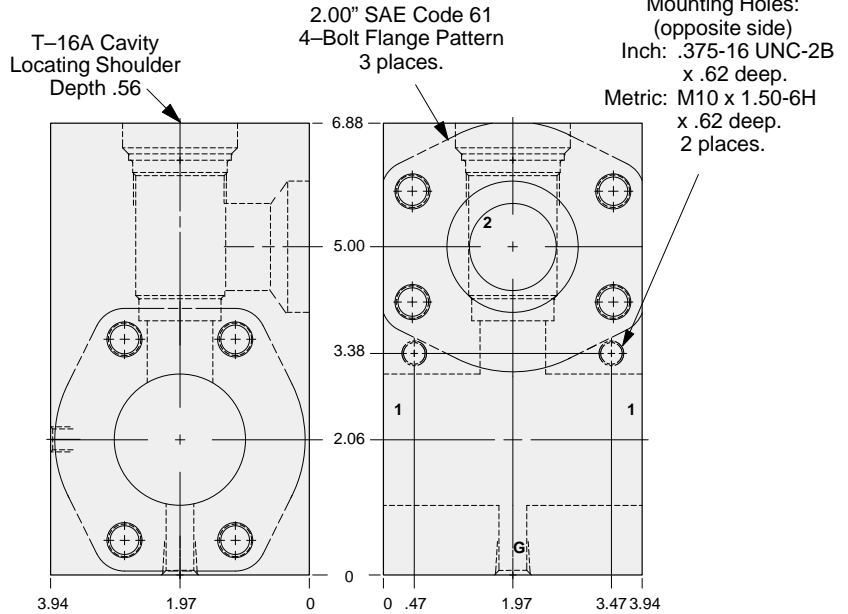

TYPICAL CARTRIDGES USED WITH THIS BODY

RPIC - ***	Page 1.07
RPIE - ***	Page 1.09
RDHA - ***	Page 1.11
RQIB - ***	Page 1.13
RPID - ***	Page 1.15
NFEC - ***	Page 5.13
CNGC - ***	Page 5.15
NCFB - ***	Page 5.17
NCFC - ***	Page 5.19
FXEA - ***	Page 5.21
FCEB - ***	Page 5.23
FDEA - ***	Page 5.25

Instructions for ordering complete cartridge and body assemblies. Page v

Pressure ratings, material specifications. Page 11.02

SAE Specifications Page 11.03

Mounting Hole Dimensions	Gage Port	ALUMINUM		DUCTILE IRON	
		Part Number	List Price	Part Number	List Price
Inch	.25 NPTF	IES		IES/S	
Metric	.25 BSPP	IES/M		IES/T	

S3 T16A

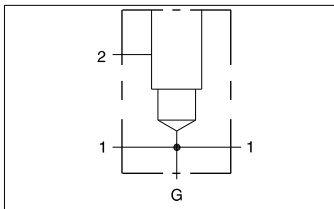

Through port 2.00" SAE Code 62 flange port body with gage port.

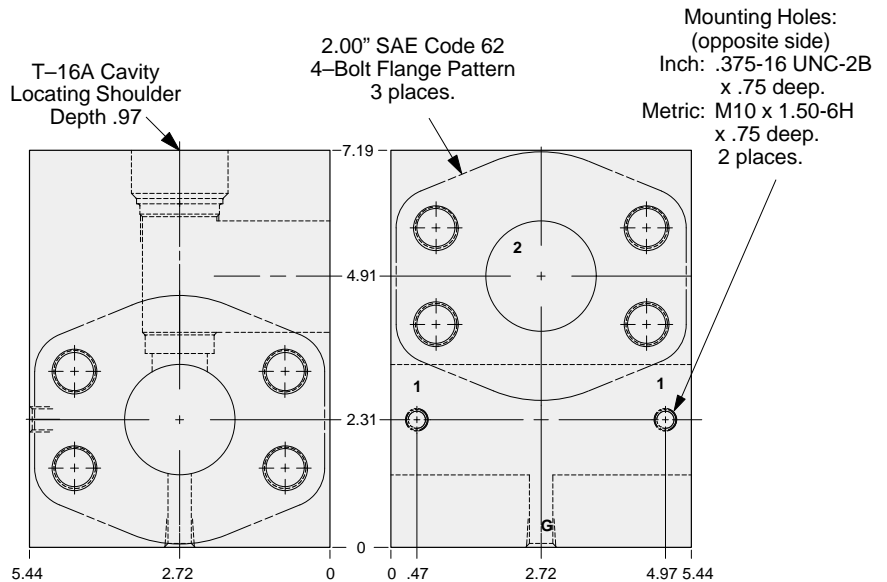

TYPICAL CARTRIDGES USED WITH THIS BODY

RPIC - ***	Page 1.07
RPIE - ***	Page 1.09
RDHA - ***	Page 1.11
RQIB - ***	Page 1.13
RPID - ***	Page 1.15
NFEC - ***	Page 5.13
CNGC - ***	Page 5.15
NCFB - ***	Page 5.17
NCFC - ***	Page 5.19
FXEA - ***	Page 5.21
FCEB - ***	Page 5.23
FDEA - ***	Page 5.25

Instructions for ordering complete cartridge and body assemblies. Page v

Pressure ratings, material specifications. Page 11.02

SAE Specifications Page 11.03

Mounting Hole Dimensions	Gage Port	ALUMINUM		DUCTILE IRON	
		Part Number	List Price	Part Number	List Price
Inch	.25 NPTF	IE8		IE8/S	
Metric	.25 BSPP	IE8/M		IE8/T	



LINE MOUNT BODIES



- Aluminum rated to 3000 psi.
- Ductile Iron rated to 5000 psi.

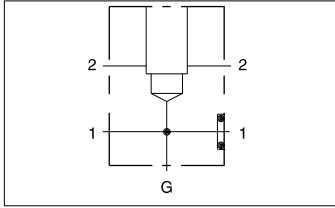

Sandwich mount through port 1.50" SAE Code 61 body with gage port.

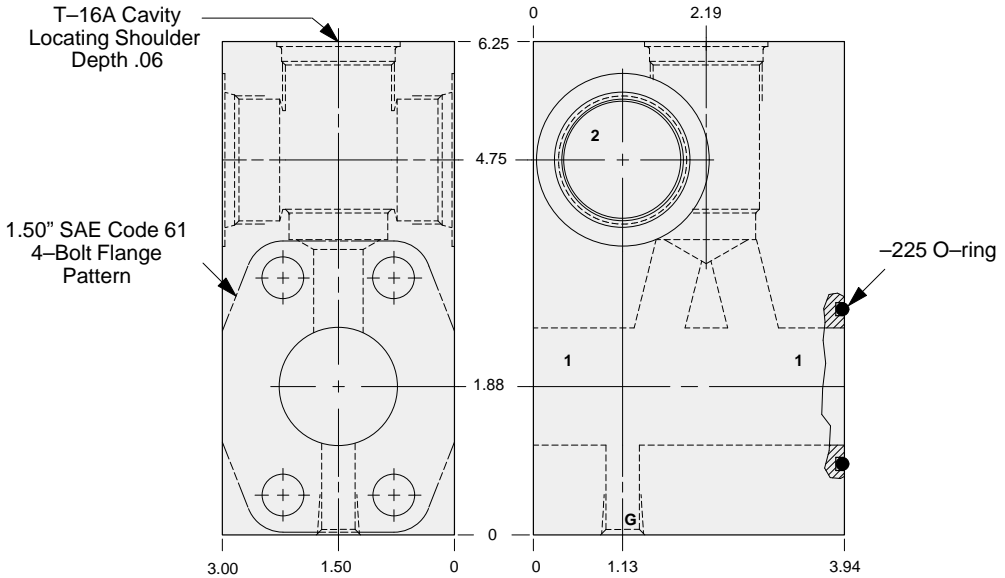

Mounting Hole Dimensions	Port 2	Gage Port	ALUMINUM		DUCTILE IRON	
			Part Number	List Price	Part Number	List Price
Inch	1.25 NPTF	.25 NPTF	ZQD		ZQD/S	
Inch	SAE-20	.25 NPTF	ZQC		ZQC/S	
Metric	1.25 BSPP	.25 BSPP	ZQB/M		ZQB/T	

S3
T16A

TYPICAL CARTRIDGES USED WITH THIS BODY

- RPIC - *** Page 1.07
- RPIE - *** Page 1.09
- RDHA - *** Page 1.11
- RQIB - *** Page 1.13
- RPID - *** Page 1.15

Cartridge seal type determines O-ring type.

Instructions for ordering complete cartridge and body assemblies. Page v

Pressure ratings, material specifications. Page 11.02

SAE Specifications Page 11.03

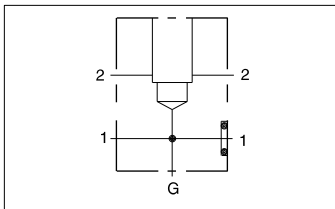

Sandwich mount through port 1.50" SAE Code 62 body with gage port.

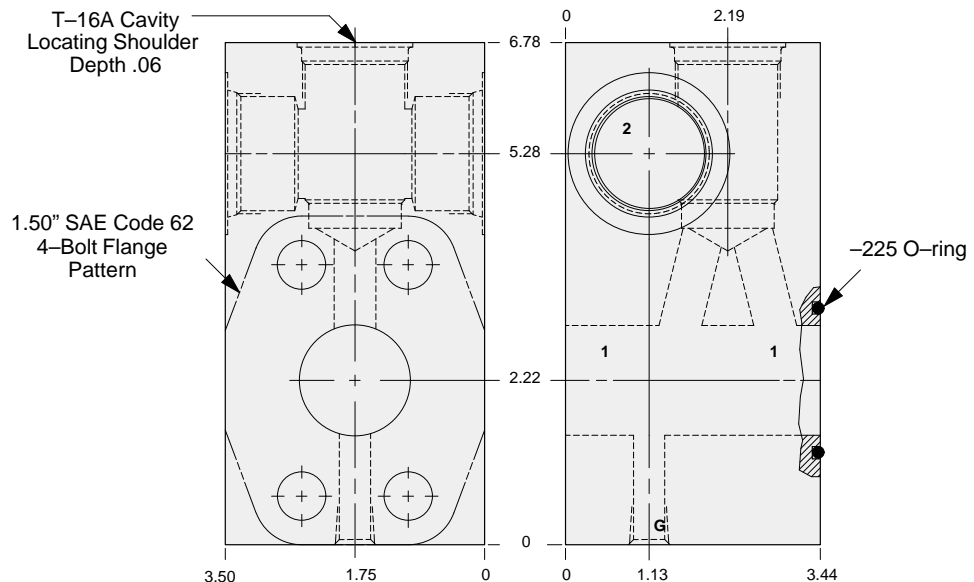

Mounting Hole Dimensions	Port 2	Gage Port	ALUMINUM		DUCTILE IRON	
			Part Number	List Price	Part Number	List Price
Inch	1.25 NPTF	.25 NPTF	ZFT		ZFT/S	
Inch	SAE-20	.25 NPTF	ZFV		ZFV/S	
Metric	1.25 BSPP	.25 BSPP	ZFW/M		ZFW/T	

TYPICAL CARTRIDGES USED WITH THIS BODY

- RPIC - *** Page 1.07
- RPIE - *** Page 1.09
- RDHA - *** Page 1.11
- RQIB - *** Page 1.13
- RPID - *** Page 1.15

Cartridge seal type determines O-ring type.

Instructions for ordering complete cartridge and body assemblies. Page v

Pressure ratings, material specifications. Page 11.02

SAE Specifications Page 11.03



LINE MOUNT BODIES



- Aluminum rated to 3000 psi.
- Ductile Iron rated to 5000 psi.

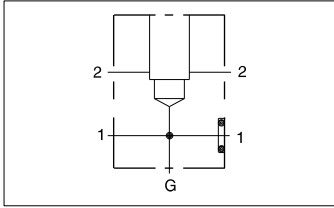

Sandwich mount through flange port 1.50" SAE Code 61 body with gage port.

TYPICAL CARTRIDGES USED WITH THIS BODY

- RPIC - *** Page 1.07
- RPIE - *** Page 1.09
- RDHA - *** Page 1.11
- RQIB - *** Page 1.13
- RPID - *** Page 1.15

Cartridge seal type determines O-ring type.

Instructions for ordering complete cartridge and body assemblies. Page v

Pressure ratings, material specifications. Page 11.02

SAE Specifications Page 11.03

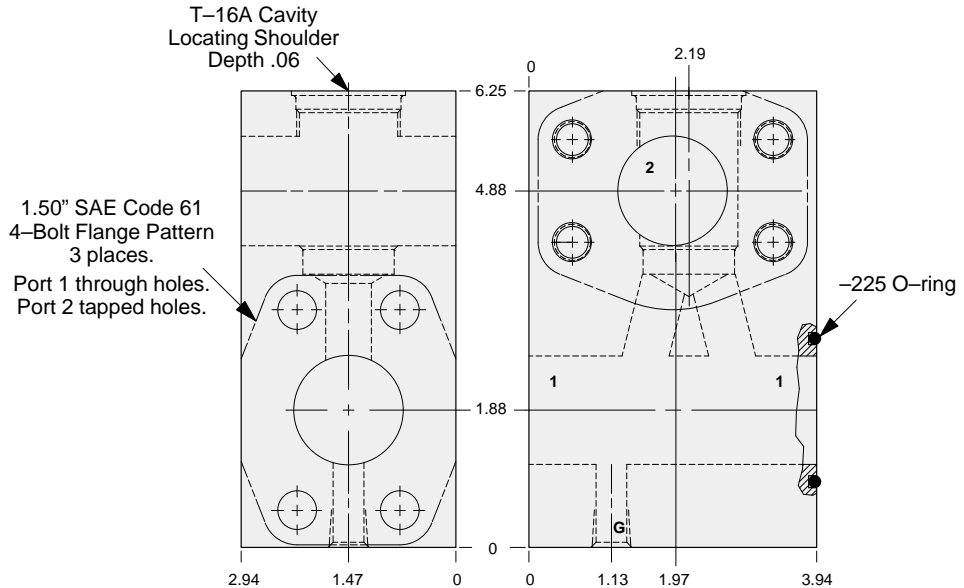

Mounting Hole Dimensions	Gage Port	ALUMINUM		DUCTILE IRON	
		Part Number	List Price	Part Number	List Price
Inch	.25 NPTF	ZQA		ZQA/S	
Metric	.25 BSPP	ZQA/M		ZQA/T	

S3
T16A

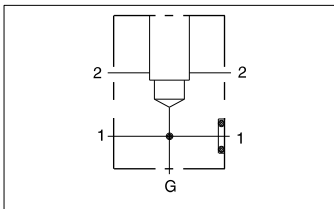

Sandwich mount through flange port 1.50" SAE Code 62 body with gage port.

TYPICAL CARTRIDGES USED WITH THIS BODY

- RPIC - *** Page 1.07
- RPIE - *** Page 1.09
- RDHA - *** Page 1.11
- RQIB - *** Page 1.13
- RPID - *** Page 1.15

Cartridge seal type determines O-ring type.

Instructions for ordering complete cartridge and body assemblies. Page v

Pressure ratings, material specifications. Page 11.02

SAE Specifications Page 11.03

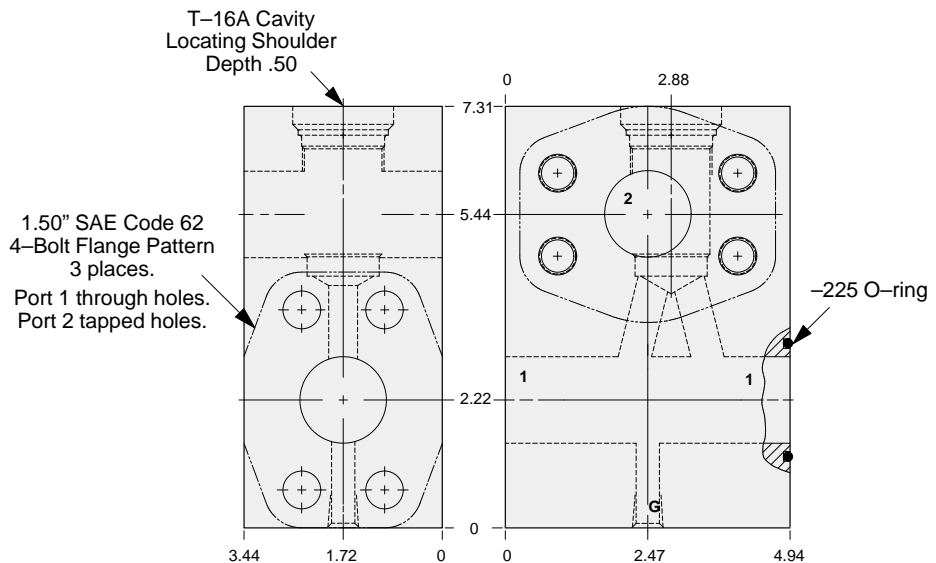

Mounting Hole Dimensions	Gage Port	ALUMINUM		DUCTILE IRON	
		Part Number	List Price	Part Number	List Price
Inch	.25 NPTF	ZBJ		ZBJ/S	
Metric	.25 BSPP	ZBJ/M		ZBJ/T	



LINE MOUNT BODIES



- Aluminum rated to 3000 psi.
- Ductile Iron rated to 5000 psi.

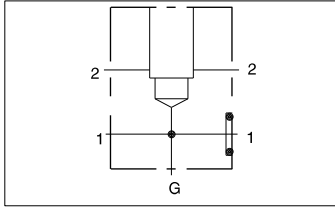

Flange mount through port 1.50" SAE Code 61 body with threaded outlet and gage port.

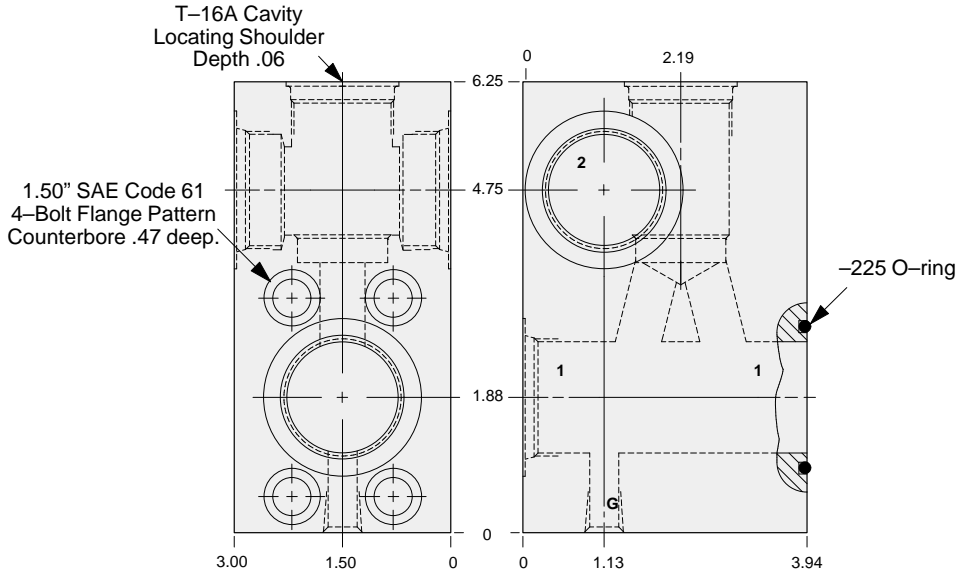

Mounting Hole Dimensions	Ports 1 & 2	Gage Port	ALUMINUM		DUCTILE IRON	
			Part Number	List Price	Part Number	List Price
Inch	1.25 NPTF	.25 NPTF	ZBQ		ZBQ/S	
Inch	SAE-20	.25 NPTF	ZBP		ZBP/S	
Metric	1.25 BSPP	.25 BSPP	ZBN/M		ZBN/T	

S3
T16A

TYPICAL CARTRIDGES USED WITH THIS BODY

- RPIC - *** Page 1.07
 RPIE - *** Page 1.09
 RDHA - *** Page 1.11
 RQIB - *** Page 1.13

Cartridge seal type determines O-ring type.

Instructions for ordering complete cartridge and body assemblies. Page v

Pressure ratings, material specifications. Page 11.02

SAE Specifications Page 11.03

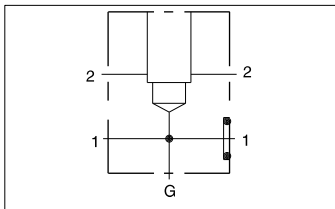

Flange mount through port 1.50" SAE Code 62 body with threaded outlet and gage port.

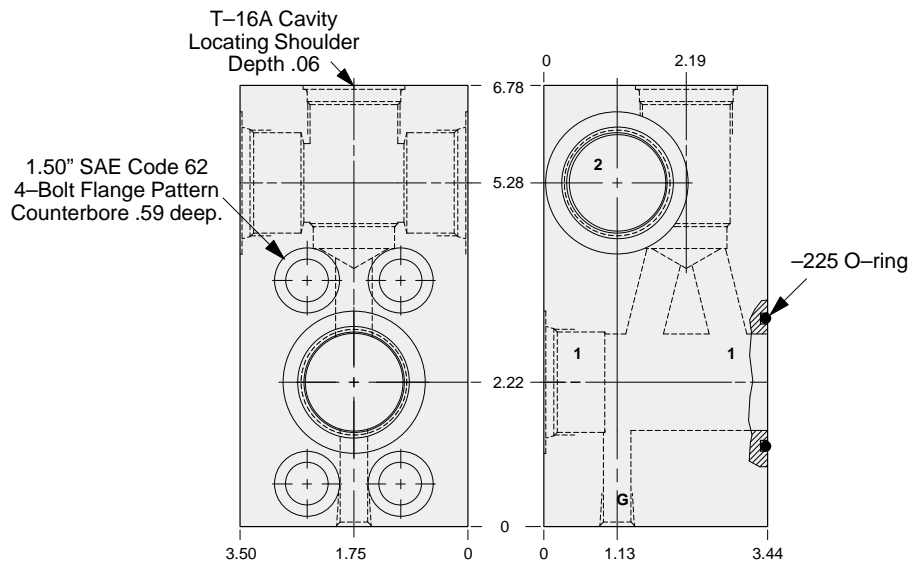

Mounting Hole Dimensions	Ports 1 & 2	Gage Port	ALUMINUM		DUCTILE IRON	
			Part Number	List Price	Part Number	List Price
Inch	1.25 NPTF	.25 NPTF	ZBM		ZBM/S	
Inch	SAE-20	.25 NPTF	ZBL		ZBL/S	
Metric	1.25 BSPP	.25 BSPP	ZBK/M		ZBK/T	

TYPICAL CARTRIDGES USED WITH THIS BODY

- RPIC - *** Page 1.07
 RPIE - *** Page 1.09
 RDHA - *** Page 1.11
 RQIB - *** Page 1.13

Cartridge seal type determines O-ring type.

Instructions for ordering complete cartridge and body assemblies. Page v

Pressure ratings, material specifications. Page 11.02

SAE Specifications Page 11.03



LINE MOUNT BODIES



- Aluminum rated to 3000 psi.
- Ductile Iron rated to 5000 psi.

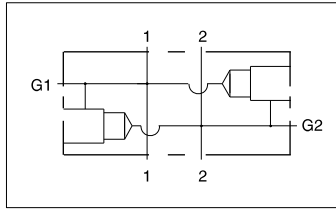

Two cavity body with gage ports for cross-port relief applications.

TYPICAL CARTRIDGES USED WITH THIS BODY

RPIC - ***	Page 1.07
RPIE - ***	Page 1.09
RDHA - ***	Page 1.11
RQIB - ***	Page 1.13

Instructions for ordering complete cartridge and body assemblies. Page v

Pressure ratings, material specifications. Page 11.02

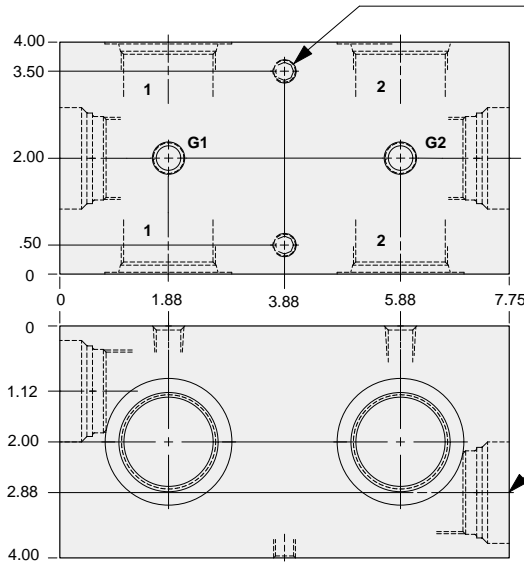

Mounting Holes:
(opposite side)
Inch: .375-16 UNC-2B
x .62 deep.
Metric: M10 x 1.50-6H
x .62 deep.
2 places.

T-16A Cavity
Locating Shoulder
Depth .56
2 places.

S3
T16A

Mounting Hole Dimensions	Ports 1 & 2	Ports G1 & G2	ALUMINUM		DUCTILE IRON	
			Part Number	List Price	Part Number	List Price
Inch	1.25 NPTF	.25 NPTF	YIF		YIF/S	
Inch	SAE-20	.25 NPTF	YIN		YIN/S	
Metric	1.25 BSPP	.25 BSPP	YIY		YIY/S	



LINE MOUNT BODIES



- Aluminum rated to 3000 psi.
- Ductile Iron rated to 5000 psi.

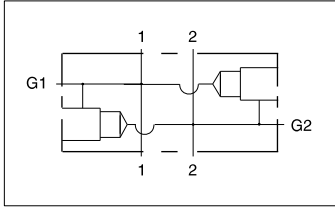

Two cavity 1.50" SAE Code 61 flange port body with gage ports for cross-port relief applications.

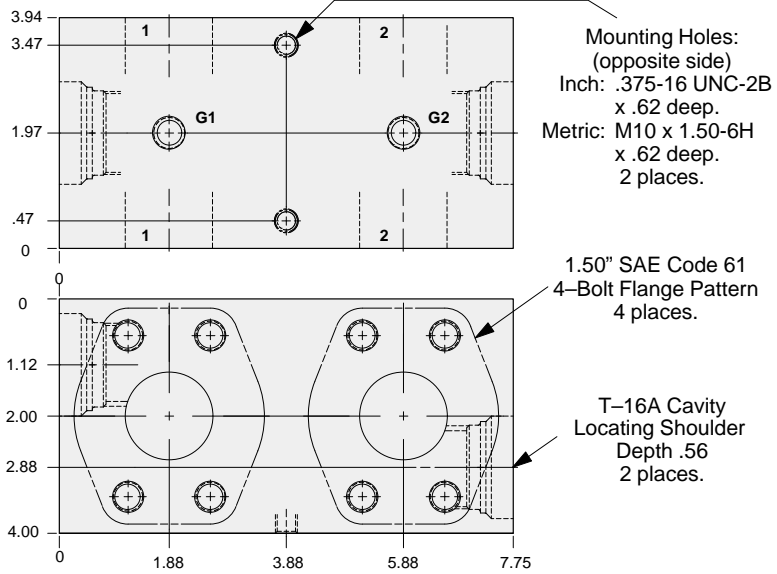

Mounting Hole Dimensions	Gage Ports	ALUMINUM		DUCTILE IRON	
		Part Number	List Price	Part Number	List Price
Inch	.25 NPTF	Y1R		Y1R/S	
Metric	.25 BSPP	Y1R/M		Y1R/T	

S3
T16A

TYPICAL CARTRIDGES USED WITH THIS BODY

RPIC - ***	Page 1.07
RPIE - ***	Page 1.09
RDHA - ***	Page 1.11
RQIB - ***	Page 1.13

Instructions for ordering complete cartridge and body assemblies. Page v

Pressure ratings, material specifications. Page 11.02

SAE Specifications Page 11.03

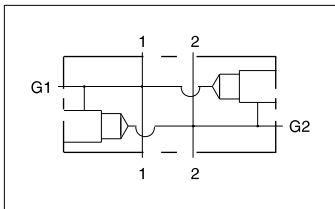

Two cavity 1.50" SAE Code 62 flange port body with gage ports for cross-port relief applications.

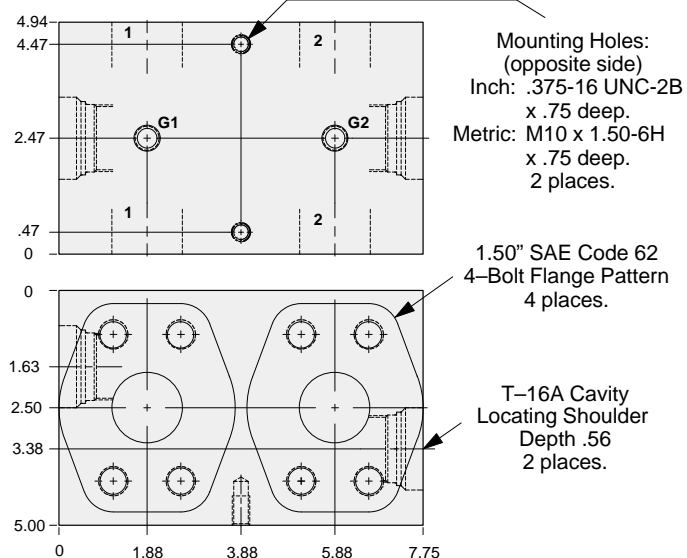

Mounting Hole Dimensions	Gage Ports	ALUMINUM		DUCTILE IRON	
		Part Number	List Price	Part Number	List Price
Inch	.25 NPTF	Y16		Y16/S	
Metric	.25 BSPP	Y16/M		Y16/T	

TYPICAL CARTRIDGES USED WITH THIS BODY

RPIC - ***	Page 1.07
RPIE - ***	Page 1.09
RDHA - ***	Page 1.11
RQIB - ***	Page 1.13

Instructions for ordering complete cartridge and body assemblies. Page v

Pressure ratings, material specifications. Page 11.02

SAE Specifications Page 11.03



LINE MOUNT BODIES



- Aluminum rated to 3000 psi.
- Ductile Iron rated to 5000 psi.

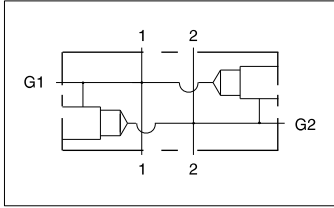

Two cavity 2.00" SAE Code 61 flange port body with gage ports for cross-port relief applications.

TYPICAL CARTRIDGES USED WITH THIS BODY

RPIC - ***	Page 1.07
RPIE - ***	Page 1.09
RDHA - ***	Page 1.11
RQIB - ***	Page 1.13

Instructions for ordering complete cartridge and body assemblies. Page v

Pressure ratings, material specifications. Page 11.02

SAE Specifications Page 11.03

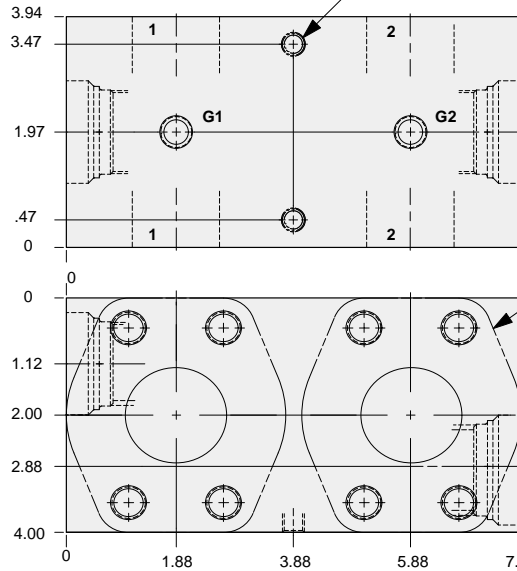

Mounting Holes:
(opposite side)
Inch: .375-16 UNC-2B
x .62 deep.
Metric: M10 x 1.50-6H
x .62 deep.
2 places.

2.00" SAE Code 61
4-Bolt Flange Pattern
4 places.

T-16A Cavity
Locating Shoulder
Depth .56
2 places.

Mounting Hole Dimensions	Gage Ports	ALUMINUM		DUCTILE IRON	
		Part Number	List Price	Part Number	List Price
Inch	.25 NPTF	YIS		YIS/S	
Metric	.25 BSPP	YIS/M		YIS/T	

S3
T16A

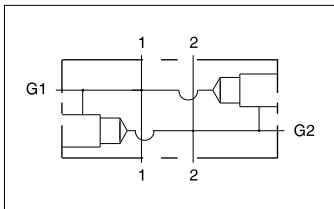

Two cavity 2.00" SAE Code 62 flange port body with gage ports for cross-port relief applications.

TYPICAL CARTRIDGES USED WITH THIS BODY

RPIC - ***	Page 1.07
RPIE - ***	Page 1.09
RDHA - ***	Page 1.11
RQIB - ***	Page 1.13

Instructions for ordering complete cartridge and body assemblies. Page v

Pressure ratings, material specifications. Page 11.02

SAE Specifications Page 11.03

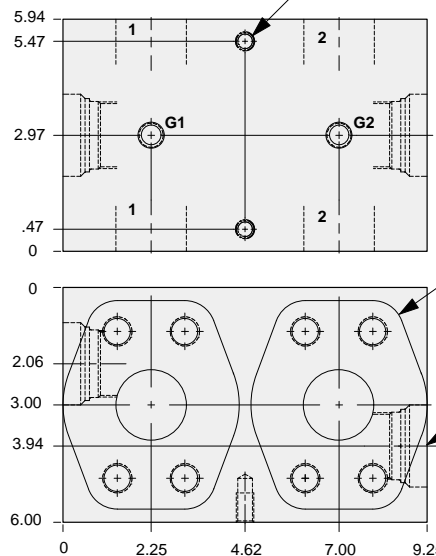

Mounting Holes:
(opposite side)
Inch: .375-16 UNC-2B
x .75 deep.
Metric: M10 x 1.50-6H
x .75 deep.
2 places.

2.00" SAE Code 62
4-Bolt Flange Pattern
4 places.

T-16A Cavity
Locating Shoulder
Depth .97
2 places.

Mounting Hole Dimensions	Gage Ports	ALUMINUM		DUCTILE IRON	
		Part Number	List Price	Part Number	List Price
Inch	.25 NPTF	Y18		Y18/S	
Metric	.25 BSPP	Y18/M		Y18/T	



LINE MOUNT BODIES



- Aluminum rated to 3000 psi.
- Ductile Iron rated to 5000 psi.

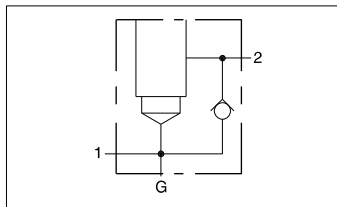

1.00" SAE Code 61 flange port body with reverse free flow check and gage port.

TYPICAL CARTRIDGES USED WITH THIS BODY

RPIC - ***	Page 1.07
RPIE - ***	Page 1.09
RDHA - ***	Page 1.11
RQIB - ***	Page 1.13
RPID - ***	Page 1.15
NFEC - ***	Page 5.13
FXEA - ***	Page 5.21

Cartridge seal type determines check valve seal type.

Instructions for ordering complete cartridge and body assemblies. Page v

Pressure ratings, material specifications. Page 11.02

SAE Specifications Page 11.03

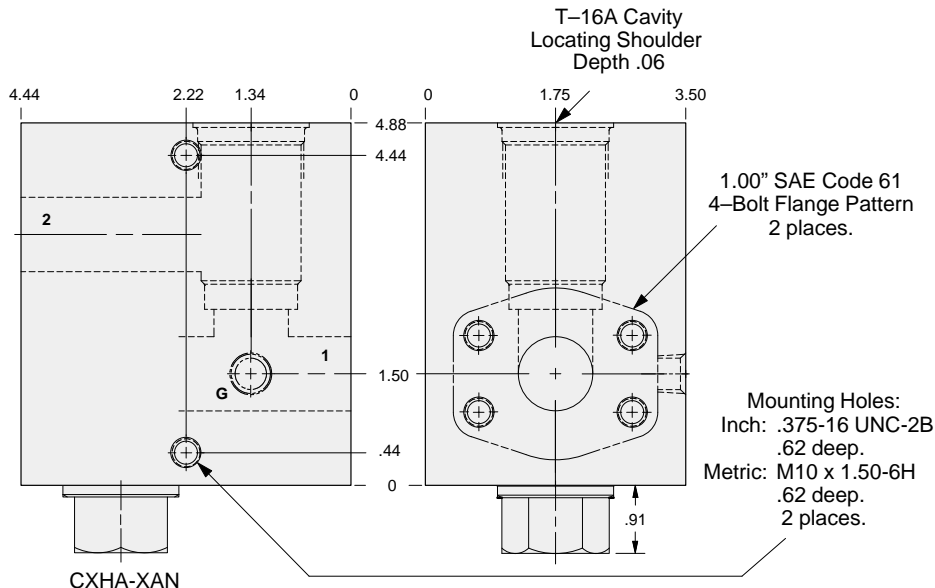

S3
T16A

Mounting Hole Dimensions	Gage Port	ALUMINUM		DUCTILE IRON	
		Part Number	List Price	Part Number	List Price
Inch	.25 NPTF	INP		INP/S	
Metric	.25 BSPP	INP/M		INP/T	

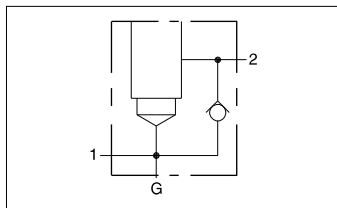

1.00" SAE Code 62 flange port body with reverse free flow check and gage port.

TYPICAL CARTRIDGES USED WITH THIS BODY

RPIC - ***	Page 1.07
RPIE - ***	Page 1.09
RDHA - ***	Page 1.11
RQIB - ***	Page 1.13
RPID - ***	Page 1.15
NFEC - ***	Page 5.13
FXEA - ***	Page 5.21

Cartridge seal type determines check valve seal type.

Instructions for ordering complete cartridge and body assemblies. Page v

Pressure ratings, material specifications. Page 11.02

SAE Specifications Page 11.03

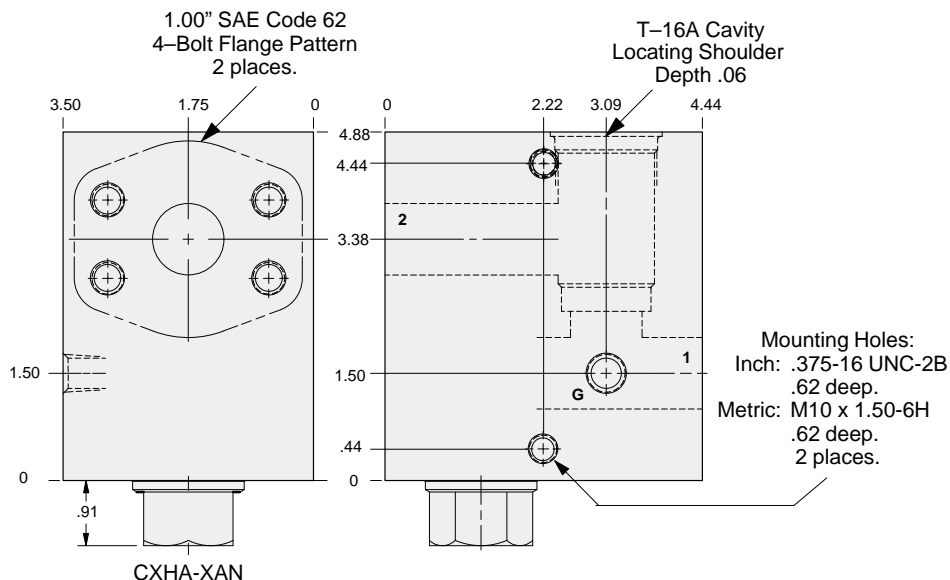

Mounting Hole Dimensions	Gage Port	ALUMINUM		DUCTILE IRON	
		Part Number	List Price	Part Number	List Price
Inch	.25 NPTF	IN4		IN4/S	
Metric	.25 BSPP	IN4/M		IN4/T	



LINE MOUNT BODIES



- Aluminum rated to 3000 psi.
- Ductile Iron rated to 5000 psi.

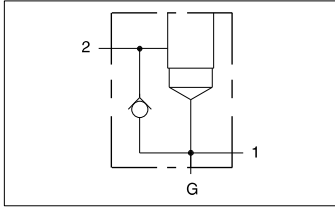

1.25" SAE Code 61 flange port body with reverse free flow check and gage port.

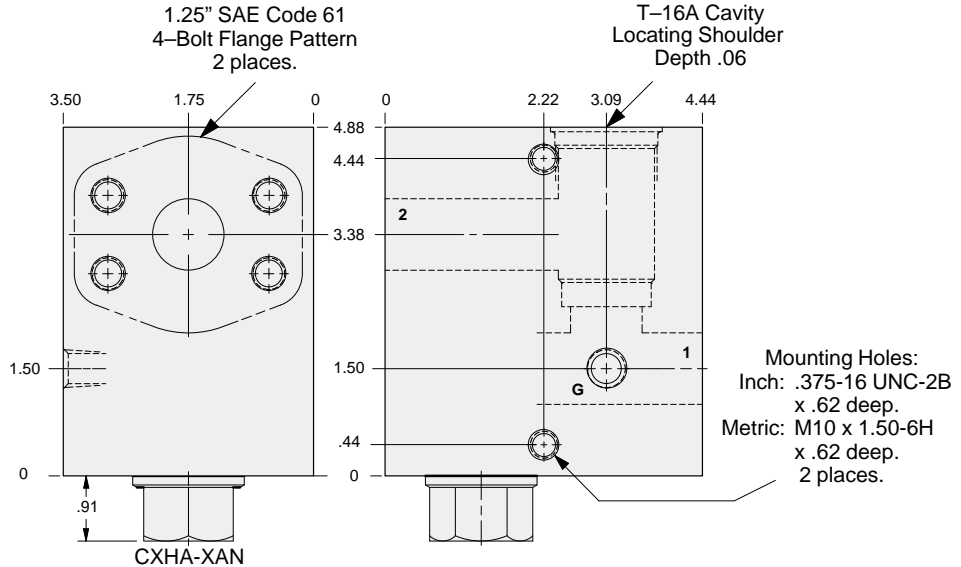

Mounting Hole Dimensions	Gage Port	ALUMINUM		DUCTILE IRON	
		Part Number	List Price	Part Number	List Price
Inch	.25 NPTF	INQ		INQ/S	
Metric	.25 BSPP	INQ/M		INQ/T	

S3
T16A

TYPICAL CARTRIDGES USED WITH THIS BODY

- RPIC - *** Page 1.07
- RPIE - *** Page 1.09
- RDHA - *** Page 1.11
- RQIB - *** Page 1.13
- RPID - *** Page 1.15
- NFEC - *** Page 5.13
- FXEA - *** Page 5.21

Cartridge seal type determines check valve seal type.

Instructions for ordering complete cartridge and body assemblies. Page v

Pressure ratings, material specifications. Page 11.02

SAE Specifications Page 11.03

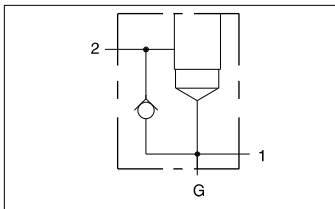

1.25" SAE Code 62 flange port body with reverse free flow check and gage port.

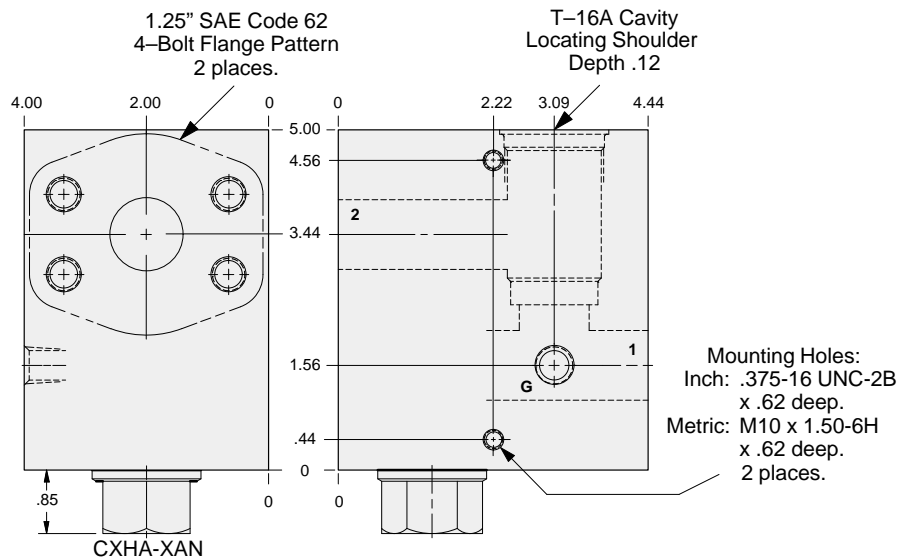

Mounting Hole Dimensions	Gage Port	ALUMINUM		DUCTILE IRON	
		Part Number	List Price	Part Number	List Price
Inch	.25 NPTF	IN5		IN5/S	
Metric	.25 BSPP	IN5/M		IN5/T	

TYPICAL CARTRIDGES USED WITH THIS BODY

- RPIC - *** Page 1.07
- RPIE - *** Page 1.09
- RDHA - *** Page 1.11
- RQIB - *** Page 1.13
- RPID - *** Page 1.15
- NFEC - *** Page 5.13
- FXEA - *** Page 5.21

Cartridge seal type determines check valve seal type.

Instructions for ordering complete cartridge and body assemblies. Page v

Pressure ratings, material specifications. Page 11.02

SAE Specifications Page 11.03



LINE MOUNT BODIES



- Aluminum rated to 3000 psi.
- Ductile Iron rated to 5000 psi.

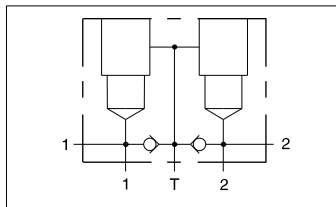

Two cavity body with make-up checks for cross-port relief applications.

TYPICAL CARTRIDGES USED WITH THIS BODY

- RPIC - *** Page 1.07
- RPIE - *** Page 1.09
- RDHA - *** Page 1.11
- RQIB - *** Page 1.13
- RPID - *** Page 1.15

Cartridge seal type determines check valve seal type.

Instructions for ordering complete cartridge and body assemblies. Page v

Pressure ratings, material specifications. Page 11.02

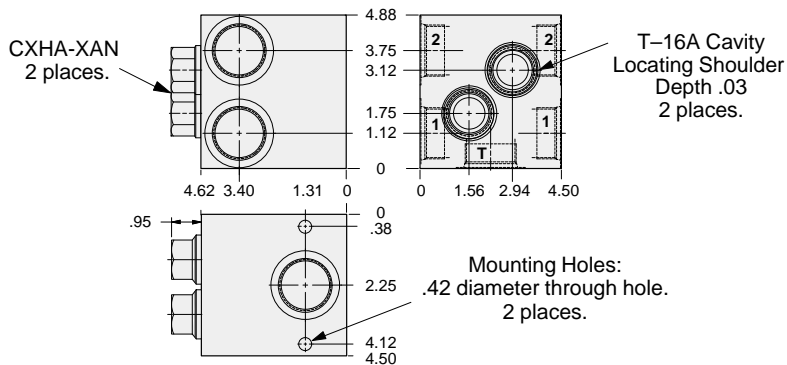

S3
T16A

All Ports	ALUMINUM		DUCTILE IRON	
	Part Number	List Price	Part Number	List Price
.75 NPTF	IMD		IMD/S	
1.00 NPTF	IME		IME/S	
1.25 NPTF	IMF		IMF/S	
SAE-12	IML		IML/S	
SAE-16	IMM		IMM/S	
SAE-20	IMN		IMN/S	
.75 BSPP	IMW		IMW/S	
1.00 BSPP	IMX		IMX/S	
1.25 BSPP	IMY		IMY/S	

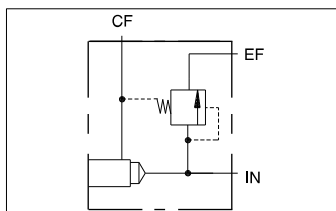

Body with moldulating element for pressure-compensated flow control applications.

TYPICAL CARTRIDGES USED WITH THIS BODY

- NFEC - *** Page 5.13
- NCFB - *** Page 5.17
- NCFC - *** Page 5.19
- FXEA - *** Page 5.21
- FCEB - *** Page 5.23
- FDEA - *** Page 5.25

Cartridge seal type determines logic element seal type.

Instructions for ordering complete cartridge and body assemblies. Page v

Pressure ratings, material specifications. Page 11.02

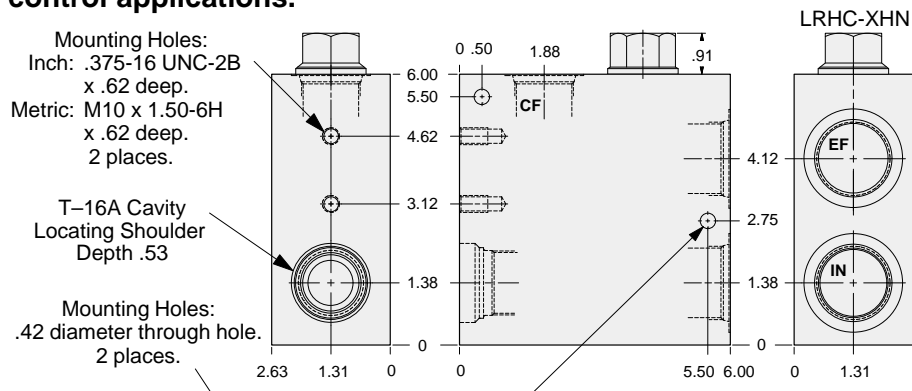

Mounting Hole Dimensions	Port CF	Ports IN, EF	ALUMINUM		DUCTILE IRON	
			Part Number	List Price	Part Number	List Price
Inch	.50 NPTF	.75 NPTF	WNI		WNI/S	
Inch	.75 NPTF	1.00 NPTF	WNJ		WNJ/S	
Inch	1.00 NPTF	1.25 NPTF	WNK		WNK/S	
Inch	SAE-10	SAE-12	WNL		WNL/S	
Inch	SAE-12	SAE-16	WNM		WNM/S	
Inch	SAE-16	SAE-20	WNN		WNN/S	
Metric	.50 BSPP	.75 BSPP	WNO		WNO/S	
Metric	.75 BSPP	1.00 BSPP	WNP		WNP/S	
Metric	1.00 BSPP	1.25 BSPP	WNQ		WNQ/S	



LINE MOUNT BODIES



- Aluminum rated to 3000 psi.
- Ductile Iron rated to 5000 psi.

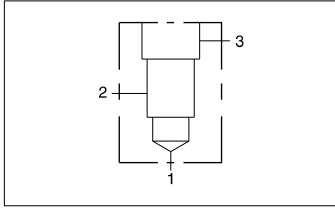

90 degree body.

Mounting Holes:
.42 diameter through hole.
2 places.

T-17A Cavity
Locating Shoulder
Depth 1.12

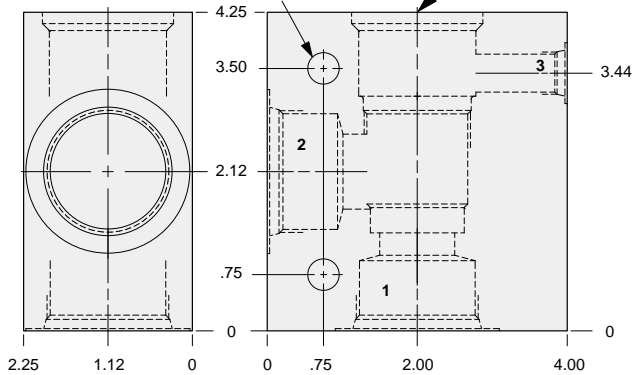

TYPICAL CARTRIDGES USED WITH THIS BODY

S3
T17A

RVGA - ***	Page 1.19
RSHC - ***	Page 2.07
SQHB - ***	Page 2.09
RSHE - ***	Page 2.11
SCGA - ***	Page 2.13
PBHB - ***	Page 3.07
PBHC - ***	Page 3.09
CBGA - ***	Page 4.11
CBGG - ***	Page 4.13
CBGH - ***	Page 4.15
CKGB - ***	Page 4.17
LOHC - ***	Page 9.09
LKHC - ***	Page 9.11
LPHC - ***	Page 9.13
LRHC - ***	Page 9.15
COHA - ***	Page 10.13

Instructions for ordering complete cartridge and body assemblies. Page v

Pressure ratings, material specifications. Page 11.02

Ports 1 & 2	Port 3	ALUMINUM		DUCTILE IRON	
		Part Number	List Price	Part Number	List Price
.75 NPTF	.25 NPTF	HCD		HCD/S	
1.00 NPTF	.25 NPTF	HCE		HCE/S	
1.25 NPTF	.25 NPTF	HCF		HCF/S	
SAE-12	SAE-6	HCL		HCL/S	
SAE-16	SAE-6	HCM		HCM/S	
SAE-20	SAE-6	HCN		HCN/S	
.75 BSPP	.25 BSPP	HCW		HCW/S	
1.00 BSPP	.25 BSPP	HGX		HGX/S	
1.25 BSPP	.25 BSPP	HCY		HCY/S	

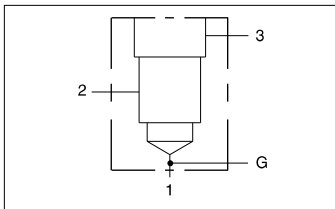

90 degree body with gage port.

T-17A Cavity
Locating Shoulder
Depth 1.16

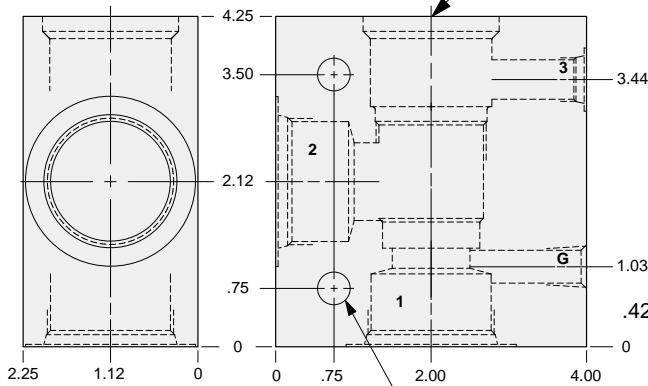

Mounting Holes:
.42 diameter through hole.
2 places.

TYPICAL CARTRIDGES USED WITH THIS BODY

RVGA - ***	Page 1.19
RSHC - ***	Page 2.07
SQHB - ***	Page 2.09
RSHE - ***	Page 2.11
SCGA - ***	Page 2.13
PBHB - ***	Page 3.07
PBHC - ***	Page 3.09
CBGA - ***	Page 4.11
CBGG - ***	Page 4.13
CBGH - ***	Page 4.15
CKGB - ***	Page 4.17
LOHC - ***	Page 9.09
LKHC - ***	Page 9.11
LPHC - ***	Page 9.13
LRHC - ***	Page 9.15
COHA - ***	Page 10.13

Instructions for ordering complete cartridge and body assemblies. Page v

Pressure ratings, material specifications. Page 11.02

Ports 1 & 2	Port 3	Gage Port	ALUMINUM		DUCTILE IRON	
			Part Number	List Price	Part Number	List Price
.75 NPTF	.25 NPTF	.25 NPTF	HFD		HFD/S	
1.00 NPTF	.25 NPTF	.25 NPTF	HFE		HFE/S	
1.25 NPTF	.25 NPTF	.25 NPTF	HFF		HFF/S	
SAE-12	SAE-6	.25 NPTF	HFL		HFL/S	
SAE-16	SAE-6	.25 NPTF	HFM		HFM/S	
SAE-20	SAE-6	.25 NPTF	HFN		HFN/S	
.75 BSPP	.25 BSPP	.25 BSPP	HFV		HFV/S	
1.00 BSPP	.25 BSPP	.25 BSPP	HFX		HFX/S	
1.25 BSPP	.25 BSPP	.25 BSPP	HFY		HFY/S	



LINE MOUNT BODIES



- Aluminum rated to 3000 psi.
- Ductile Iron rated to 5000 psi.

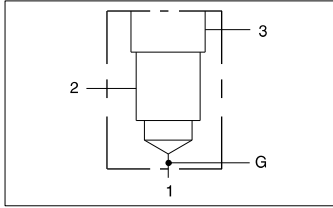

90 degree body with high capacity port 3 and gage port.

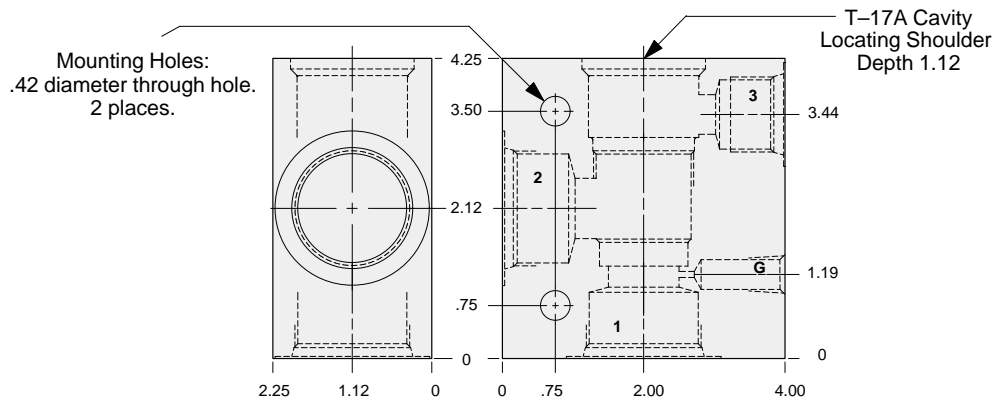

TYPICAL CARTRIDGES USED WITH THIS BODY

- PPHB - *** Page 3.11
 PPHC - *** Page 3.13
 FREA - *** Page 6.03

Instructions for ordering complete cartridge and body assemblies. Page v

Pressure ratings, material specifications. Page 11.02

Ports 1 & 2	Port 3	Gage Port	ALUMINUM		DUCTILE IRON	
			Part Number	List Price	Part Number	List Price
.75 NPTF	.75 NPTF	.25 NPTF	HED		HED/S	
1.00 NPTF	.75 NPTF	.25 NPTF	HEE		HEE/S	
1.25 NPTF	.75 NPTF	.25 NPTF	HEF		HEF/S	
SAE-12	SAE-12	.25 NPTF	HEL		HEL/S	
SAE-16	SAE-12	.25 NPTF	HEM		HEM/S	
SAE-20	SAE-12	.25 NPTF	HEN		HEN/S	
.75 BSPP	.75 BSPP	.25 BSPP	HEW		HEW/S	
1.00 BSPP	.75 BSPP	.25 BSPP	HEX		HEX/S	
1.25 BSPP	.75 BSPP	.25 BSPP	HEY		HEY/S	

S3
T17A

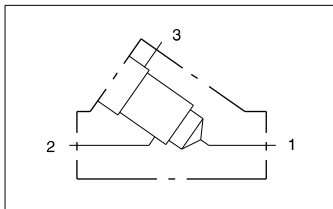

Inline body.

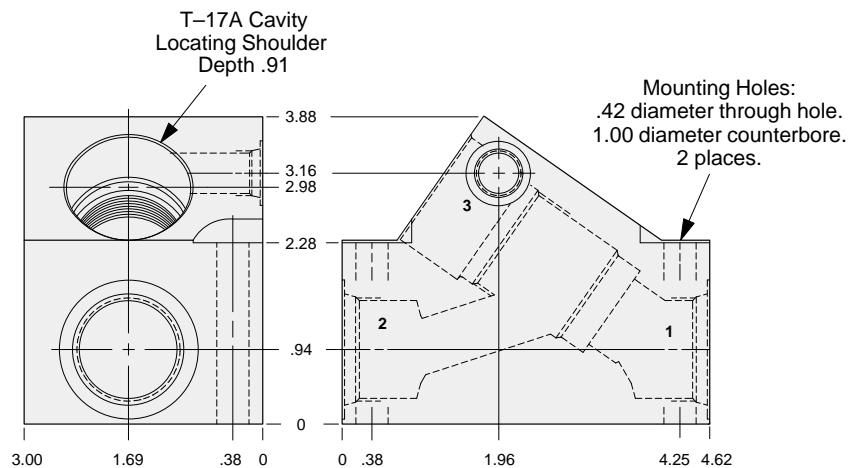

TYPICAL CARTRIDGES USED WITH THIS BODY

- RVGA - *** Page 1.19
 RSHC - *** Page 2.07
 SQHB - *** Page 2.09
 RSHE - *** Page 2.11
 SCGA - *** Page 2.13
 PBHB - *** Page 3.07
 PBHC - *** Page 3.09
 CBGA - *** Page 4.11
 CBGG - *** Page 4.13
 CBGH - *** Page 4.15
 CKGB - *** Page 4.17
 LOHC - *** Page 9.09
 LKHC - *** Page 9.11
 LPHC - *** Page 9.13
 LRHC - *** Page 9.15
 COHA - *** Page 10.13

Instructions for ordering complete cartridge and body assemblies. Page v

Pressure ratings, material specifications. Page 11.02

Ports 1 & 2	Port 3	ALUMINUM		DUCTILE IRON	
		Part Number	List Price	Part Number	List Price
.75 NPTF	.25 NPTF	HDD		HDD/S	
1.00 NPTF	.25 NPTF	HDE		HDE/S	
SAE-12	SAE-6	HDL		HDL/S	
SAE-16	SAE-6	HDM		HDM/S	
.75 BSPP	.25 BSPP	HDW		HDW/S	
1.00 BSPP	.25 BSPP	HDX		HDX/S	



LINE MOUNT BODIES



- Aluminum rated to 3000 psi.
- Ductile Iron rated to 5000 psi.

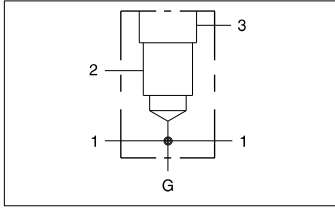

Through port body with gage port.

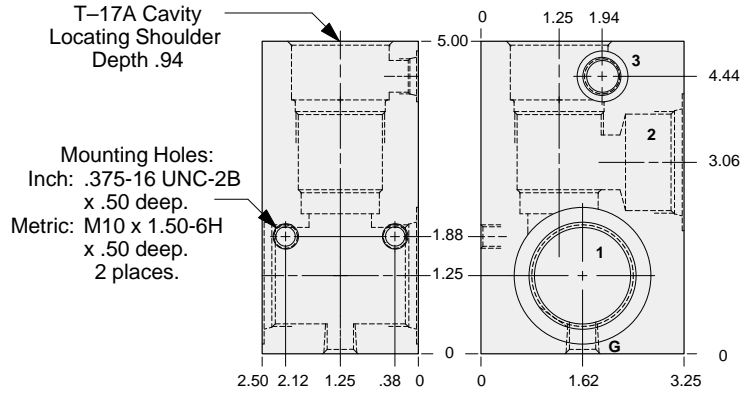

TYPICAL CARTRIDGES USED WITH THIS BODY

S3
T17A

RVGA - ***	Page 1.19
RSHC - ***	Page 2.07
SQHB - ***	Page 2.09
RSHE - ***	Page 2.11
SCGA - ***	Page 2.13
PBHB - ***	Page 3.07
PBHC - ***	Page 3.09

Instructions for ordering complete cartridge and body assemblies. Page v

Pressure ratings, material specifications. Page 11.02

Mounting Hole Dimensions	Ports 1 & 2	Port 3	Gage Port	ALUMINUM		DUCTILE IRON	
				Part Number	List Price	Part Number	List Price
Inch .75 NPTF	.25 NPTF	.25 NPTF	.25 NPTF	HHD		HHD/S	
Inch 1.00 NPTF	.25 NPTF	.25 NPTF	.25 NPTF	HHE		HHE/S	
Inch 1.25 NPTF	.25 NPTF	.25 NPTF	.25 NPTF	HHF		HHF/S	
Inch SAE-12	SAE-6	.25 NPTF	.25 NPTF	HHL		HHL/S	
Inch SAE-16	SAE-6	.25 NPTF	.25 NPTF	HHM		HHM/S	
Inch SAE-20	SAE-6	.25 NPTF	.25 NPTF	HHN		HHN/S	
Metric .75 BSPP	.25 BSPP	.75 BSPP	.75 BSPP	HHW		HHW/S	
Metric 1.00 BSPP	.25 BSPP	.75 BSPP	.75 BSPP	HHX		HHX/S	
Metric 1.25 BSPP	.25 BSPP	.75 BSPP	.75 BSPP	HHY		HHY/S	



LINE MOUNT BODIES



- Aluminum rated to 3000 psi.
- Ductile Iron rated to 5000 psi.

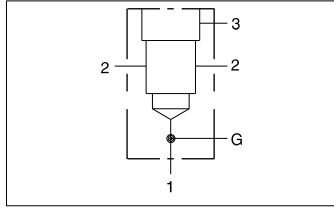

TYPICAL CARTRIDGES USED WITH THIS BODY

PBHB - *** Page 3.07
 PBHC - *** Page 3.09

Instructions for ordering complete cartridge and body assemblies. Page v

Pressure ratings, material specifications. Page 11.02

Through port body with gage port for reducing applications.

Mounting Holes:
 (opposite side)
 Inch: .375-16 UNC-2B
 x .62 deep.
 Metric: M10 x 1.50-6H
 x .62 deep.
 2 places.

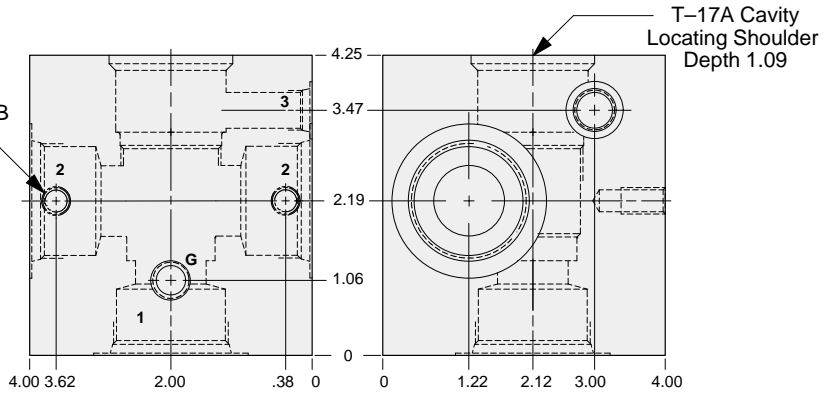

Mounting Hole Dimensions	Ports 1 & 2	Port 3	Gage Port	ALUMINUM		DUCTILE IRON	
				Part Number	List Price	Part Number	List Price
Inch .75 NPTF	.25 NPTF	.25 NPTF	.25 NPTF	WSW		WSW/S	
Inch 1.00 NPTF	.25 NPTF	.25 NPTF	.25 NPTF	WSX		WSX/S	
Inch 1.25 NPTF	.25 NPTF	.25 NPTF	.25 NPTF	WSY		WSY/S	
Inch SAE-12	SAE-6	.25 NPTF	.25 NPTF	WSZ		WSZ/S	
Inch SAE-16	SAE-6	.25 NPTF	.25 NPTF	WTA		WTA/S	
Inch SAE-20	SAE-6	.25 NPTF	.25 NPTF	WTB		WTB/S	
Metric .75 BSPP	.25 BSPP	.25 BSPP	.25 BSPP	WTC		WTC/S	
Metric 1.00 BSPP	.25 BSPP	.25 BSPP	.25 BSPP	WTD		WTD/S	
Metric 1.25 BSPP	.25 BSPP	.25 BSPP	.25 BSPP	WTE		WTE/S	

S3
T17A

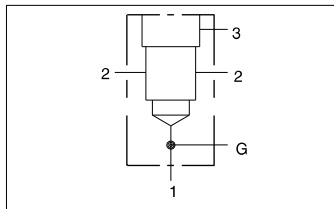

TYPICAL CARTRIDGES USED WITH THIS BODY

PPHB - *** Page 3.11
 PPHC - *** Page 3.13
 FREA - *** Page 6.03

Instructions for ordering complete cartridge and body assemblies. Page v

Pressure ratings, material specifications. Page 11.02

Through port body with high capacity port 3 and gage port for reducing/relieving applications.

Mounting Holes:
 (opposite side)
 Inch: .375-16 UNC-2B
 x .62 deep.
 Metric: M10 x 1.50-6H
 x .62 deep.
 2 places.

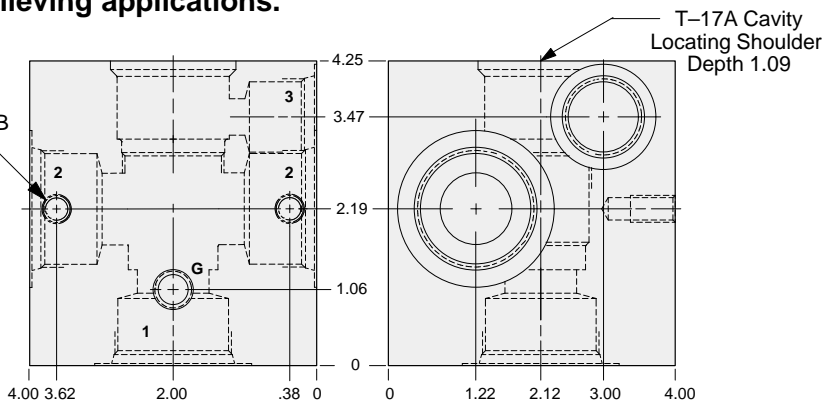

Mounting Hole Dimensions	Ports 1 & 2	Port 3	Gage Port	ALUMINUM		DUCTILE IRON	
				Part Number	List Price	Part Number	List Price
Inch .75 NPTF	.75 NPTF	.75 NPTF	.25 NPTF	WTF		WTF/S	
Inch 1.00 NPTF	.75 NPTF	.75 NPTF	.25 NPTF	WTG		WTG/S	
Inch 1.25 NPTF	.75 NPTF	.75 NPTF	.25 NPTF	WTH		WTH/S	
Inch SAE-12	SAE-12	.25 NPTF	.25 NPTF	WTI		WTI/S	
Inch SAE-16	SAE-12	.25 NPTF	.25 NPTF	WTJ		WTJ/S	
Inch SAE-20	SAE-12	.25 NPTF	.25 NPTF	WTK		WTK/S	
Metric .75 BSPP	.75 BSPP	.25 BSPP	.25 BSPP	WTL		WTL/S	
Metric 1.00 BSPP	.75 BSPP	.25 BSPP	.25 BSPP	WTM		WTM/S	
Metric 1.25 BSPP	.75 BSPP	.25 BSPP	.25 BSPP	WTN		WTN/S	



LINE MOUNT BODIES



- Aluminum rated to 3000 psi.
- Ductile Iron rated to 5000 psi.

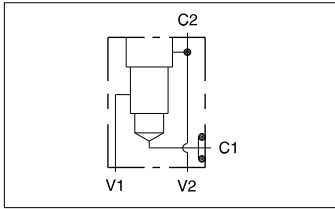

Gasket mount body for load control applications.

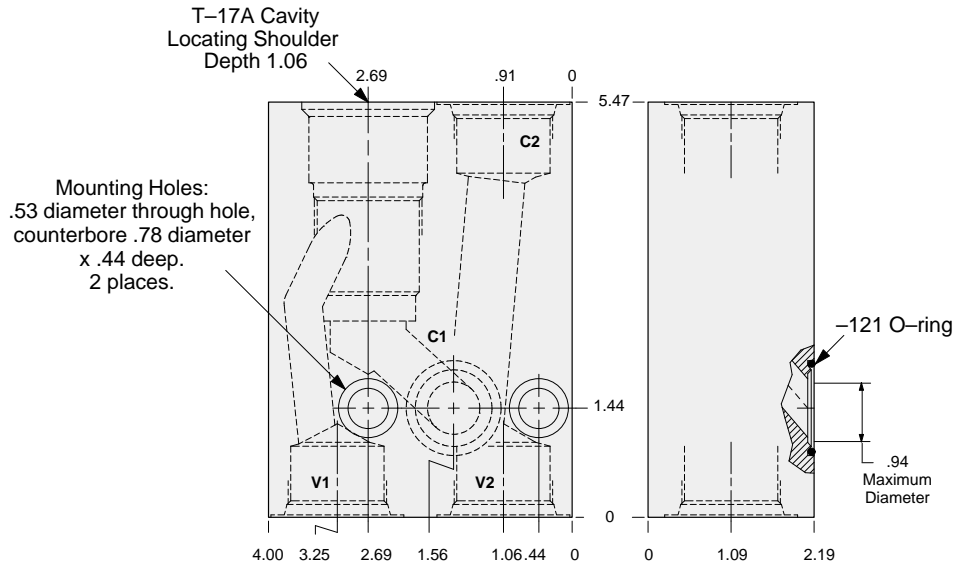

TYPICAL CARTRIDGES USED WITH THIS BODY

S3
T17A

- CBGA - *** Page 4.11
- CBGG - *** Page 4.13
- CBGH - *** Page 4.15
- CKGB - *** Page 4.17

Cartridge seal type determines O-ring type.

Instructions for ordering complete cartridge and body assemblies. Page v

Pressure ratings, material specifications. Page 11.02

Ports V1, V2, C2	ALUMINUM		DUCTILE IRON	
	Part Number	List Price	Part Number	List Price
.75 NPTF	ZTJ		ZTJ/S	
SAE-12	ZTK		ZTK/S	
.75 BSPP	ZTL		ZTL/S	

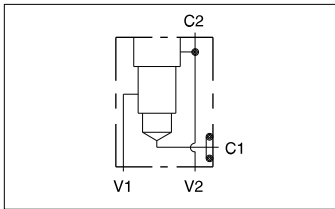

Gasket mount body for load control applications.

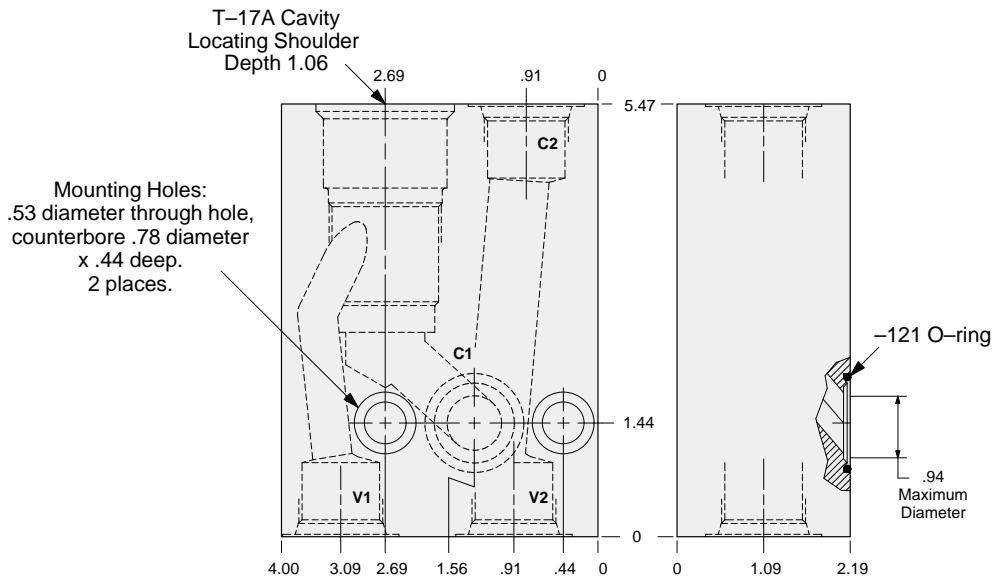

TYPICAL CARTRIDGES USED WITH THIS BODY

- CBGA - *** Page 4.11
- CBGG - *** Page 4.13
- CBGH - *** Page 4.15
- CKGB - *** Page 4.17

Cartridge seal type determines O-ring type.

Instructions for ordering complete cartridge and body assemblies. Page v

Pressure ratings, material specifications. Page 11.02

Ports V1, V2, C2	ALUMINUM		DUCTILE IRON	
	Part Number	List Price	Part Number	List Price
SAE-16	ZTM		ZTM/S	



LINE MOUNT BODIES



- Aluminum rated to 3000 psi.
- Ductile Iron rated to 5000 psi.

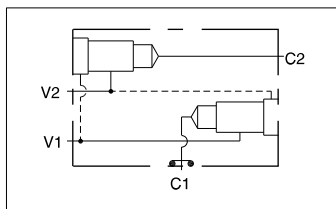

Two cavity gasket mount body for dual load control applications.

TYPICAL CARTRIDGES USED WITH THIS BODY

- CBGA - *** Page 4.11
- CBGG - *** Page 4.13
- CBGH - *** Page 4.15
- CKGB - *** Page 4.17

Cartridge seal type determines O-ring type.

Instructions for ordering complete cartridge and body assemblies. Page v

Pressure ratings, material specifications. Page 11.02

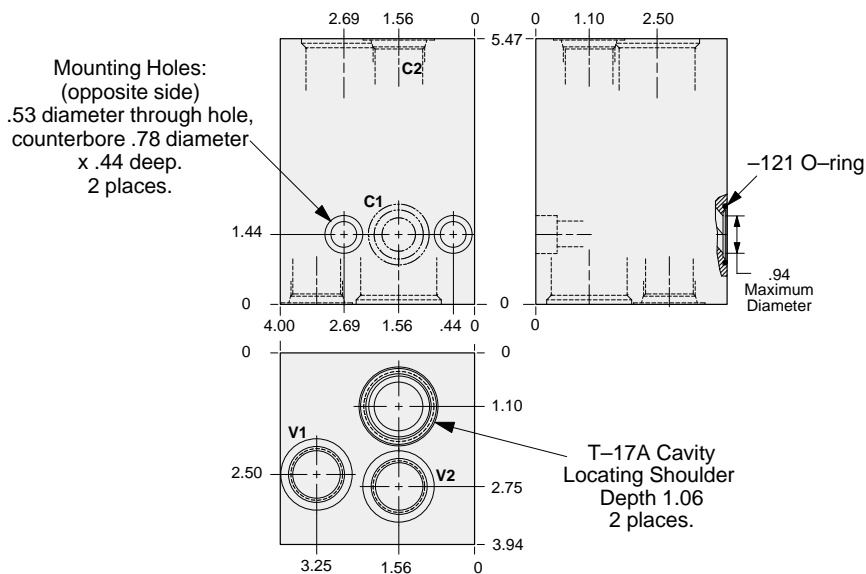

S3
T17A

Ports V1, V2, C2	ALUMINUM		DUCTILE IRON	
	Part Number	List Price	Part Number	List Price
.75 NPTF	YVT		YVT/S	
SAE-12	YVS		YVS/S	
.75 BSPP	YVR		YVR/S	

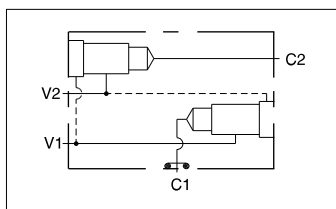

Two cavity gasket mount body for dual load control applications.

TYPICAL CARTRIDGES USED WITH THIS BODY

- CBGA - *** Page 4.11
- CBGG - *** Page 4.13
- CBGH - *** Page 4.15
- CKGB - *** Page 4.17

Cartridge seal type determines O-ring type.

Instructions for ordering complete cartridge and body assemblies. Page v

Pressure ratings, material specifications. Page 11.02

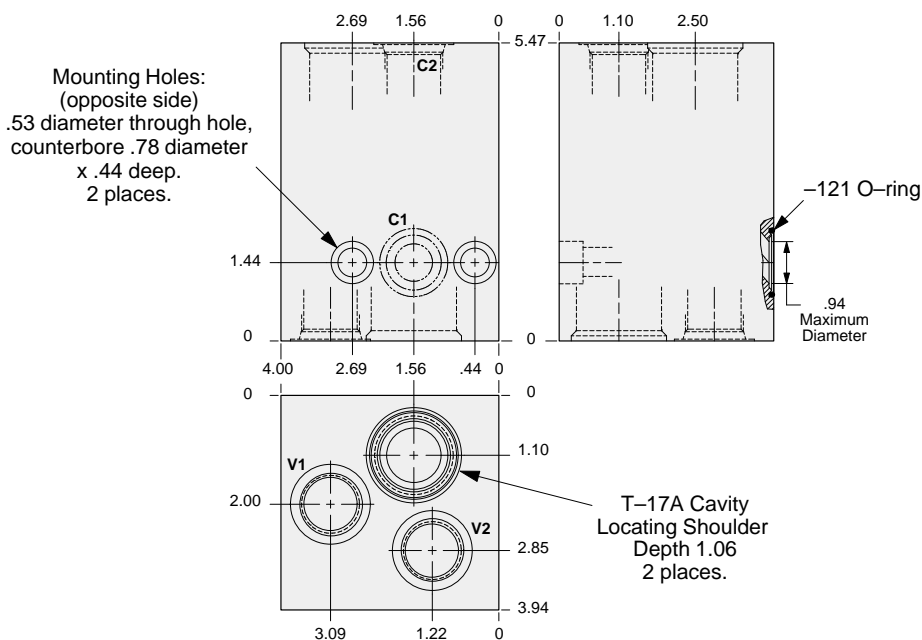

Ports V1, V2, C2	ALUMINUM		DUCTILE IRON	
	Part Number	List Price	Part Number	List Price
SAE-16	YVQ		YVQ/S	



LINE MOUNT BODIES



- Aluminum rated to 3000 psi.
- Ductile Iron rated to 5000 psi.

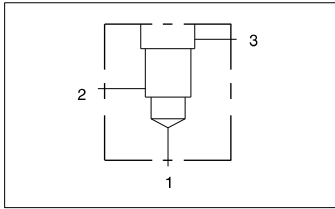

90 degree 1.00" SAE Code 61 flange port body.

TYPICAL CARTRIDGES USED WITH THIS BODY

S3
T17A

RVGA - ***	Page 1.19
RSHC - ***	Page 2.07
SQHB - ***	Page 2.09
RSHE - ***	Page 2.11
SCGA - ***	Page 2.13
PBHB - ***	Page 3.07
PBHC - ***	Page 3.09
CBGA - ***	Page 4.11
CBGG - ***	Page 4.13
CBGH - ***	Page 4.15
CKGB - ***	Page 4.17
LOHC - ***	Page 9.09
LKHC - ***	Page 9.11
LPHC - ***	Page 9.13
LRHC - ***	Page 9.15
COHA - ***	Page 10.13

Instructions for ordering complete cartridge and body assemblies. Page v

Pressure ratings, material specifications. Page 11.02

SAE Specifications Page 11.03

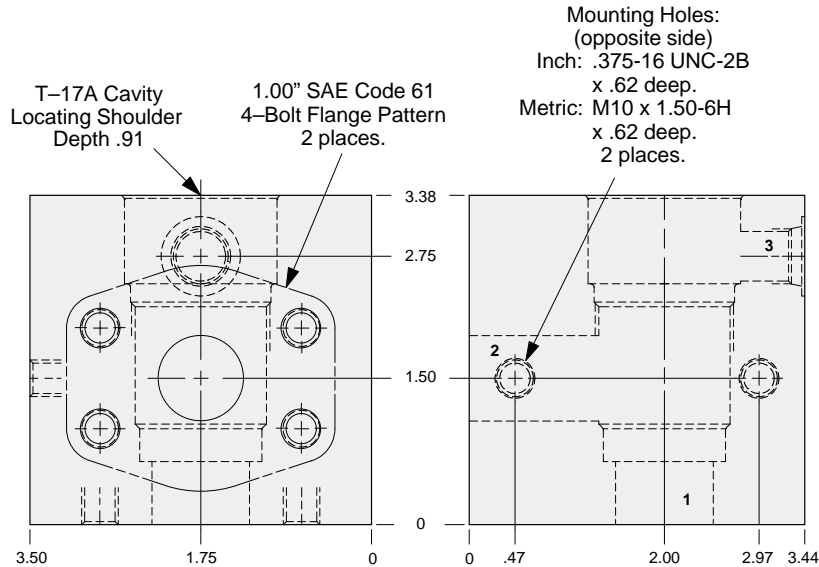

Mounting Hole Dimensions	Port 3	ALUMINUM		DUCTILE IRON	
		Part Number	List Price	Part Number	List Price
Inch	SAE-6	HCP		HCP/S	
Metric	.25 BSPP	HCP/M		HCP/T	

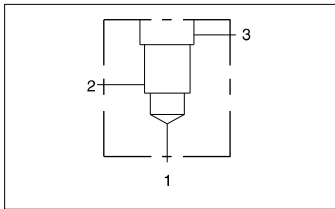

90 degree 1.00" SAE Code 62 flange port body.

TYPICAL CARTRIDGES USED WITH THIS BODY

RVGA - ***	Page 1.19
RSHC - ***	Page 2.07
SQHB - ***	Page 2.09
RSHE - ***	Page 2.11
SCGA - ***	Page 2.13
PBHB - ***	Page 3.07
PBHC - ***	Page 3.09
CBGA - ***	Page 4.11
CBGG - ***	Page 4.13
CBGH - ***	Page 4.15
CKGB - ***	Page 4.17
LOHC - ***	Page 9.09
LKHC - ***	Page 9.11
LPHC - ***	Page 9.13
LRHC - ***	Page 9.15
COHA - ***	Page 10.13

Instructions for ordering complete cartridge and body assemblies. Page v

Pressure ratings, material specifications. Page 11.02

SAE Specifications Page 11.03

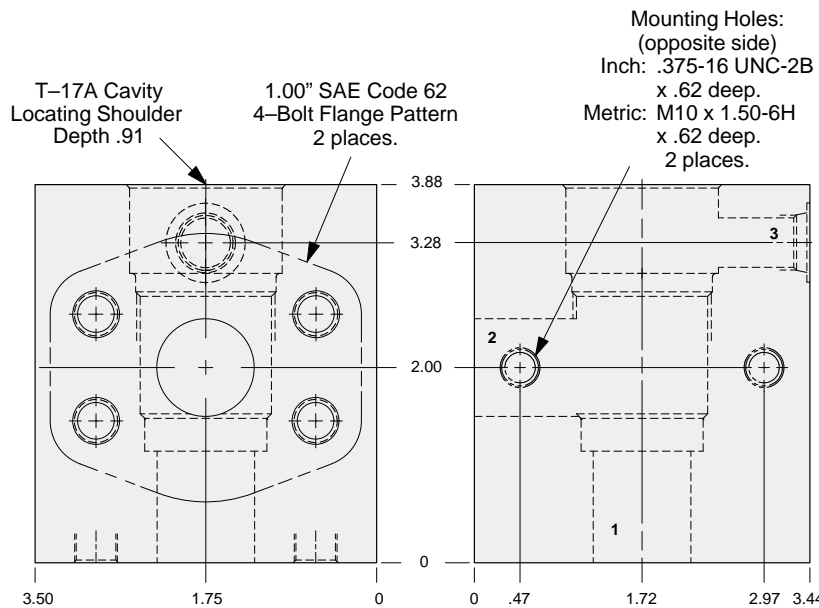

Mounting Hole Dimensions	Port 3	ALUMINUM		DUCTILE IRON	
		Part Number	List Price	Part Number	List Price
Inch	SAE-6	HC4		HC4/S	
Metric	.25 BSPP	HC4/M		HC4/T	



LINE MOUNT BODIES



- Aluminum rated to 3000 psi.
- Ductile Iron rated to 5000 psi.

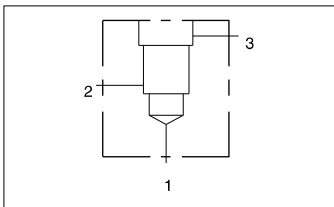

90 degree 1.25" SAE Code 61 flange port body.

TYPICAL CARTRIDGES USED WITH THIS BODY

RVGA - ***	Page 1.19
RSHC - ***	Page 2.07
SQHB - ***	Page 2.09
RSHE - ***	Page 2.11
SCGA - ***	Page 2.13
PBHB - ***	Page 3.07
PBHC - ***	Page 3.09
CBGA - ***	Page 4.11
CBGG - ***	Page 4.13
CBGH - ***	Page 4.15
CKGB - ***	Page 4.17
LOHC - ***	Page 9.09
LKHC - ***	Page 9.11
LPHC - ***	Page 9.13
LRHC - ***	Page 9.15
COHA - ***	Page 10.13

Instructions for ordering complete cartridge and body assemblies. Page v

Pressure ratings, material specifications. Page 11.02

SAE Specifications Page 11.03

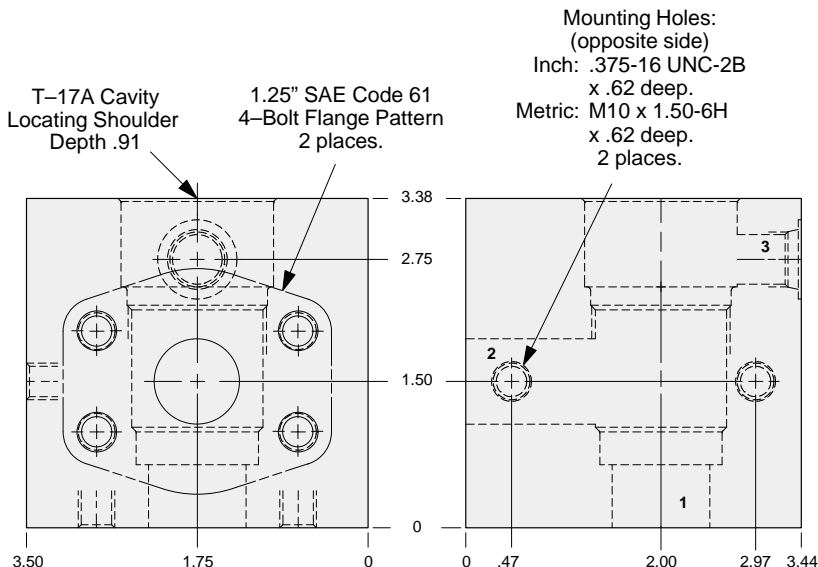

Mounting Hole Dimensions	Port 3	ALUMINUM		DUCTILE IRON	
		Part Number	List Price	Part Number	List Price
Inch	SAE-6	HCQ		HCQ/S	
Metric	.25 BSPP	HCQ/M		HCQ/T	

S3
T17A

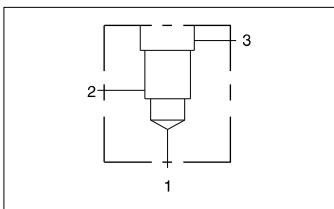

90 degree 1.25" SAE Code 62 flange port body.

TYPICAL CARTRIDGES USED WITH THIS BODY

RVGA - ***	Page 1.19
RSHC - ***	Page 2.07
SQHB - ***	Page 2.09
RSHE - ***	Page 2.11
SCGA - ***	Page 2.13
PBHB - ***	Page 3.07
PBHC - ***	Page 3.09
CBGA - ***	Page 4.11
CBGG - ***	Page 4.13
CBGH - ***	Page 4.15
CKGB - ***	Page 4.17
LOHC - ***	Page 9.09
LKHC - ***	Page 9.11
LPHC - ***	Page 9.13
LRHC - ***	Page 9.15
COHA - ***	Page 10.13

Instructions for ordering complete cartridge and body assemblies. Page v

Pressure ratings, material specifications. Page 11.02

SAE Specifications Page 11.03

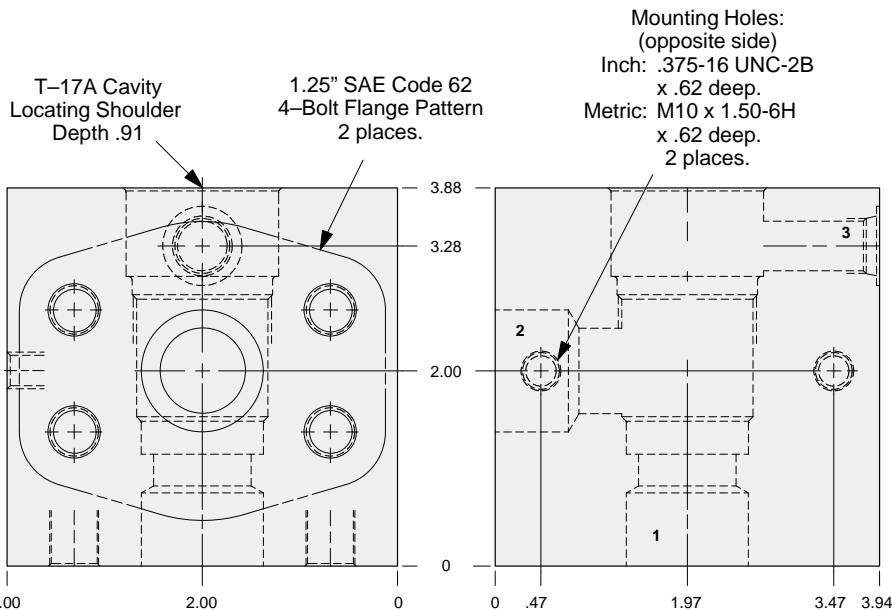

Mounting Hole Dimensions	Port 3	ALUMINUM		DUCTILE IRON	
		Part Number	List Price	Part Number	List Price
Inch	SAE-6	HC5		HC5/S	
Metric	.25 BSPP	HC5/M		HC5/T	



LINE MOUNT BODIES



- Aluminum rated to 3000 psi.
- Ductile Iron rated to 5000 psi.

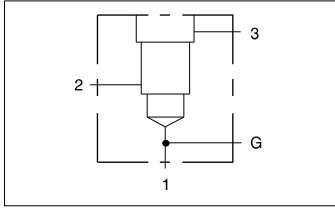

90 degree 1.00" SAE Code 61 flange port body with gage port.

Mounting Holes:
(opposite side)
Inch: .375-16 UNC-2B
x .62 deep.
Metric: M10 x 1.50-6H
x .62 deep.
2 places.

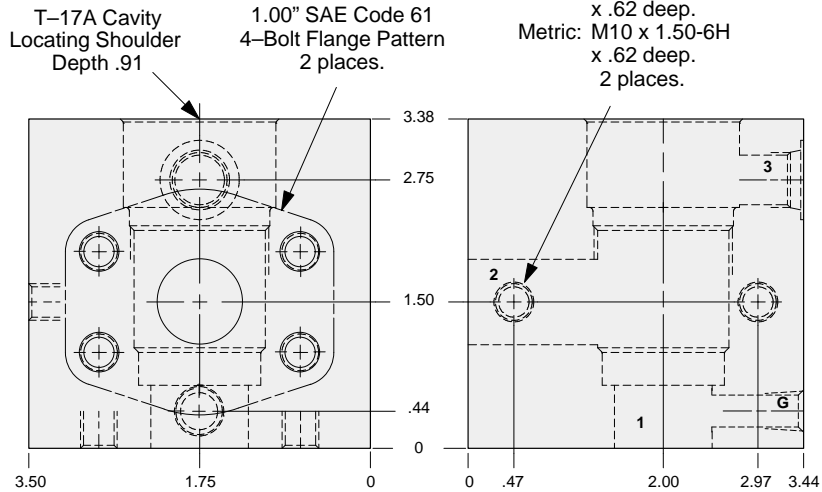

TYPICAL CARTRIDGES USED WITH THIS BODY

S3
T17A

RVGA - ***	Page 1.19
RSHC - ***	Page 2.07
SQHB - ***	Page 2.09
RSHE - ***	Page 2.11
SCGA - ***	Page 2.13
PBHB - ***	Page 3.07
PBHC - ***	Page 3.09
CBGA - ***	Page 4.11
CBGG - ***	Page 4.13
CBGH - ***	Page 4.15
CKGB - ***	Page 4.17
LOHC - ***	Page 9.09
LKHC - ***	Page 9.11
LPHC - ***	Page 9.13
LRHC - ***	Page 9.15
COHA - ***	Page 10.13

Instructions for ordering complete cartridge and body assemblies. Page v

Pressure ratings, material specifications. Page 11.02

SAE Specifications Page 11.03

Mounting Hole Dimensions	Port 3	Gage Port	ALUMINUM		DUCTILE IRON	
			Part Number	List Price	Part Number	List Price
Inch	SAE-6	.25 NPTF	HFP		HFP/S	
Metric	.25 BSPP	.25 BSPP	HFP/M		HFP/T	

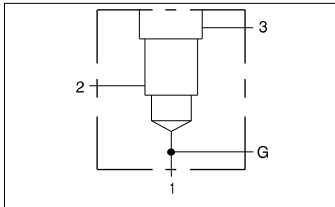

90 degree 1.00" SAE Code 62 flange port body with gage port.

Mounting Holes:
(opposite side)
Inch: .375-16 UNC-2B
x .62 deep.
Metric: M10 x 1.50-6H
x .62 deep.
2 places.

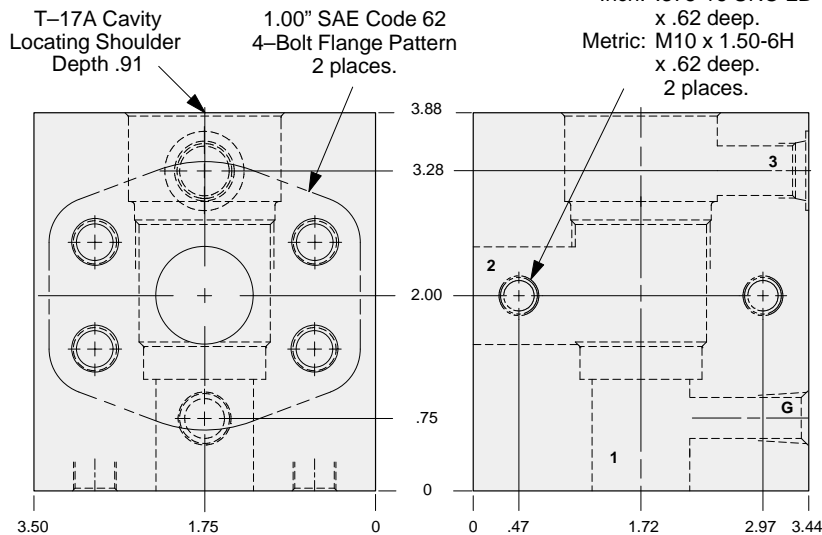

TYPICAL CARTRIDGES USED WITH THIS BODY

RVGA - ***	Page 1.19
RSHC - ***	Page 2.07
SQHB - ***	Page 2.09
RSHE - ***	Page 2.11
SCGA - ***	Page 2.13
PBHB - ***	Page 3.07
PBHC - ***	Page 3.09
CBGA - ***	Page 4.11
CBGG - ***	Page 4.13
CBGH - ***	Page 4.15
CKGB - ***	Page 4.17
LOHC - ***	Page 9.09
LKHC - ***	Page 9.11
LPHC - ***	Page 9.13
LRHC - ***	Page 9.15
COHA - ***	Page 10.13

Instructions for ordering complete cartridge and body assemblies. Page v

Pressure ratings, material specifications. Page 11.02

SAE Specifications Page 11.03

Mounting Hole Dimensions	Port 3	Gage Port	ALUMINUM		DUCTILE IRON	
			Part Number	List Price	Part Number	List Price
Inch	SAE-6	.25 NPTF	HF4		HF4/S	
Metric	.25 BSPP	.25 BSPP	HF4/M		HF4/T	



LINE MOUNT BODIES



- Aluminum rated to 3000 psi.
- Ductile Iron rated to 5000 psi.

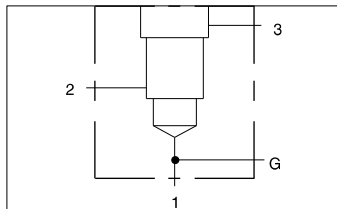

90 degree 1.25" SAE Code 61 flange port body with gage port.

TYPICAL CARTRIDGES USED WITH THIS BODY

RVGA - ***	Page 1.19
RSHC - ***	Page 2.07
SQHB - ***	Page 2.09
RSHE - ***	Page 2.11
SCGA - ***	Page 2.13
PBHB - ***	Page 3.07
PBHC - ***	Page 3.09
CBGA - ***	Page 4.11
CBGG - ***	Page 4.13
CBGH - ***	Page 4.15
CKGB - ***	Page 4.17
LOHC - ***	Page 9.09
LKHC - ***	Page 9.11
LPHC - ***	Page 9.13
LRHC - ***	Page 9.15
COHA - ***	Page 10.13

Instructions for ordering complete cartridge and body assemblies. Page v

Pressure ratings, material specifications. Page 11.02

SAE Specifications Page 11.03

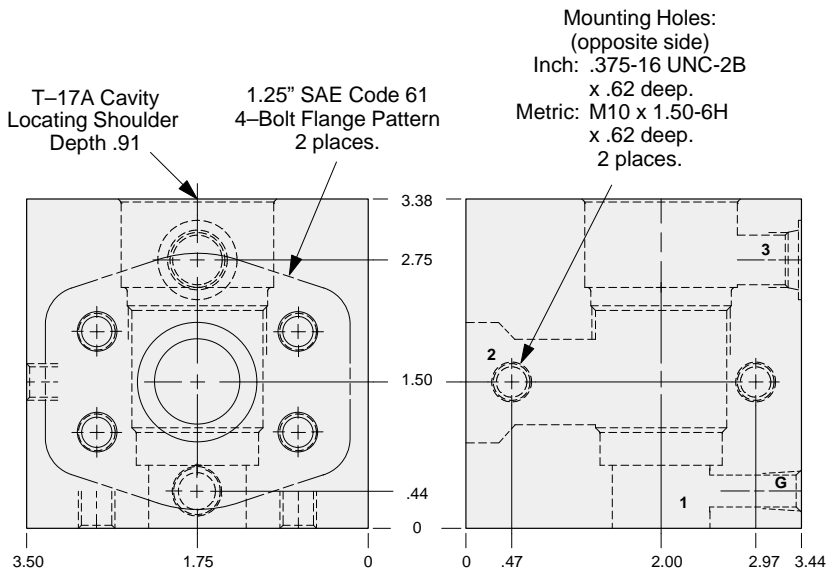

Mounting Hole Dimensions	Port 3	Gage Port	ALUMINUM		DUCTILE IRON	
			Part Number	List Price	Part Number	List Price
Inch	SAE-6	.25 NPTF	HFQ		HFQ/S	
Metric	.25 BSPP	.25 BSPP	HFQ/M		HFQ/T	

S3
T17A

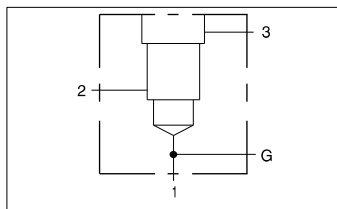

90 degree 1.25" SAE Code 62 flange port body with gage port.

TYPICAL CARTRIDGES USED WITH THIS BODY

RVGA - ***	Page 1.19
RSHC - ***	Page 2.07
SQHB - ***	Page 2.09
RSHE - ***	Page 2.11
SCGA - ***	Page 2.13
PBHB - ***	Page 3.07
PBHC - ***	Page 3.09
CBGA - ***	Page 4.11
CBGG - ***	Page 4.13
CBGH - ***	Page 4.15
CKGB - ***	Page 4.17
LOHC - ***	Page 9.09
LKHC - ***	Page 9.11
LPHC - ***	Page 9.13
LRHC - ***	Page 9.15
COHA - ***	Page 10.13

Instructions for ordering complete cartridge and body assemblies. Page v

Pressure ratings, material specifications. Page 11.02

SAE Specifications Page 11.03

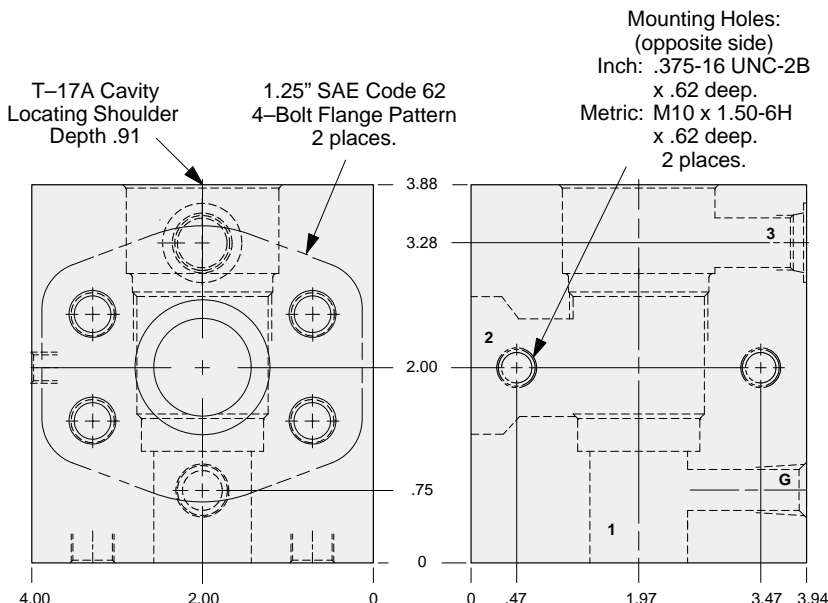

Mounting Hole Dimensions	Port 3	Gage Port	ALUMINUM		DUCTILE IRON	
			Part Number	List Price	Part Number	List Price
Inch	SAE-6	.25 NPTF	HF5		HF5/S	
Metric	.25 BSPP	.25 BSPP	HF5/M		HF5/T	



LINE MOUNT BODIES



- Aluminum rated to 3000 psi.
- Ductile Iron rated to 5000 psi.

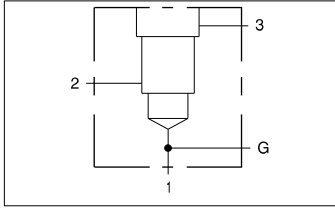

90 degree 1.00" SAE Code 61 flange port body with high capacity port 3 and gage port.

Mounting Holes:
(opposite side)
Inch: .375-16 UNC-2B
x .62 deep.
Metric: M10 x 1.50-6H
x .62 deep.
2 places.

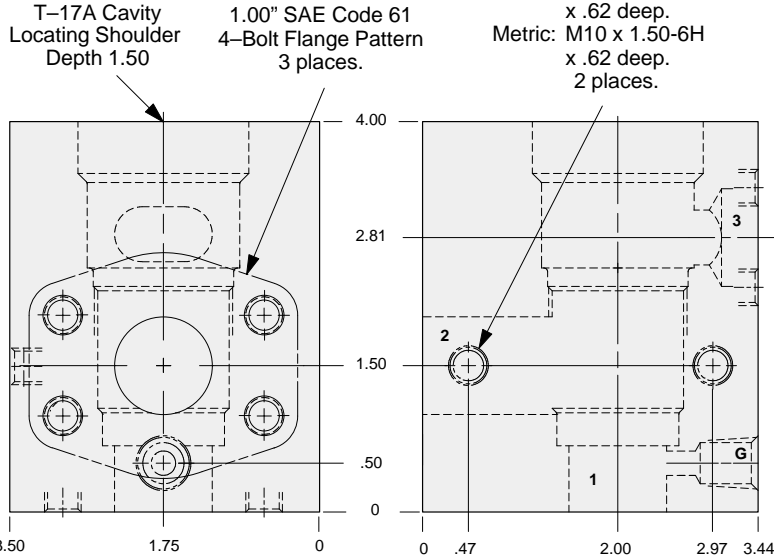

TYPICAL CARTRIDGES USED WITH THIS BODY

S3
T17A

PPHB - *** Page 3.11
PPHC - *** Page 3.13
FREA - *** Page 6.03

Instructions for ordering complete cartridge and body assemblies. Page v

Pressure ratings, material specifications. Page 11.02

SAE Specifications Page 11.03

Mounting Hole Dimensions	Gage Port	ALUMINUM		DUCTILE IRON	
		Part Number	List Price	Part Number	List Price
Inch	.25 NPTF	HEP		HEP/S	
Metric	.25 BSPP	HEP/M		HEP/T	

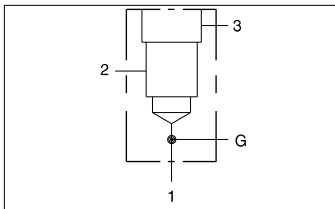

90 degree 1.00" SAE Code 62 flange port body with high capacity port 3 and gage port.

Mounting Holes:
(opposite side)
Inch: .375-16 UNC-2B
x .62 deep.
Metric: M10 x 1.50-6H
x .62 deep.
2 places.

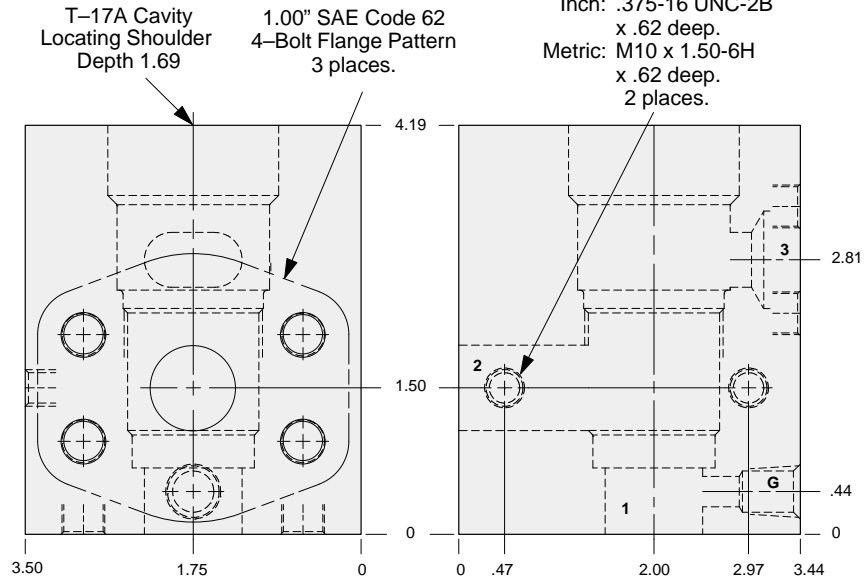

TYPICAL CARTRIDGES USED WITH THIS BODY

PPHB - *** Page 3.11
PPHC - *** Page 3.13
FREA - *** Page 6.03

Instructions for ordering complete cartridge and body assemblies. Page v

Pressure ratings, material specifications. Page 11.02

SAE Specifications Page 11.03

Mounting Hole Dimensions	Gage Port	ALUMINUM		DUCTILE IRON	
		Part Number	List Price	Part Number	List Price
Inch	.25 NPTF	HE4		HE4/S	
Metric	.25 BSPP	HE4/M		HE4/T	



LINE MOUNT BODIES



- Aluminum rated to 3000 psi.
- Ductile Iron rated to 5000 psi.

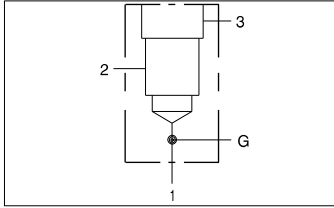

90 degree 1.25" SAE Code 61 flange port body with high capacity port 3 and gage port.

TYPICAL CARTRIDGES USED WITH THIS BODY

- PPHB - *** Page 3.11
 PPHC - *** Page 3.13
 FREA - *** Page 6.03

Instructions for ordering complete cartridge and body assemblies. Page v

Pressure ratings, material specifications. Page 11.02

SAE Specifications Page 11.03

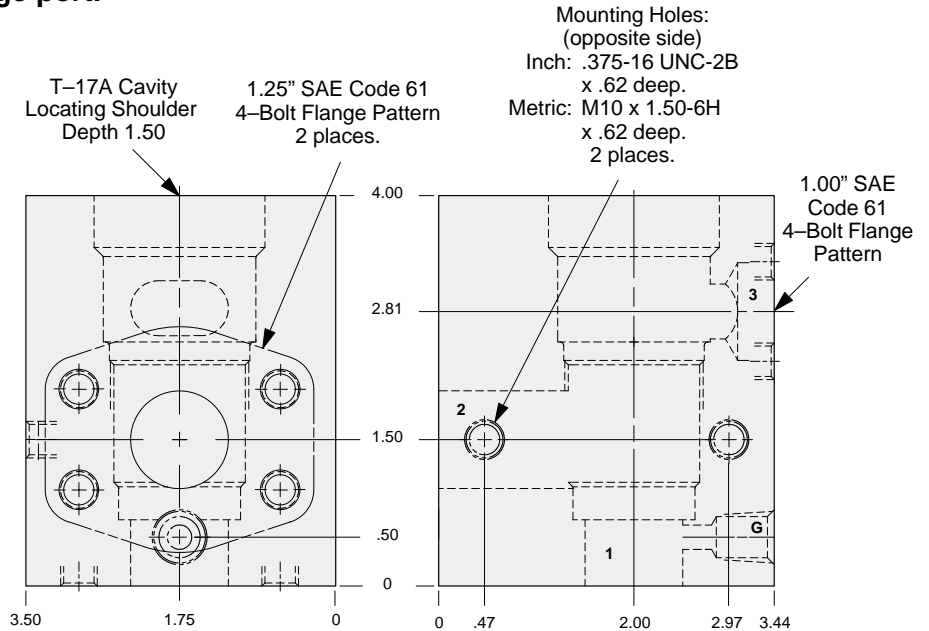

S3
T17A

Mounting Hole Dimensions	Gage Port	ALUMINUM		DUCTILE IRON	
		Part Number	List Price	Part Number	List Price
Inch	.25 NPTF	HEQ		HEQ/S	
Metric	.25 BSPP	HEQ/M		HEQ/T	

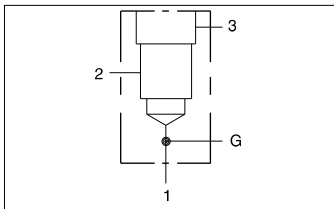

90 degree 1.25" SAE Code 62 flange port body with high capacity port 3 and gage port.

TYPICAL CARTRIDGES USED WITH THIS BODY

- PPHB - *** Page 3.11
 PPHC - *** Page 3.13
 FREA - *** Page 6.03

Instructions for ordering complete cartridge and body assemblies. Page v

Pressure ratings, material specifications. Page 11.02

SAE Specifications Page 11.03

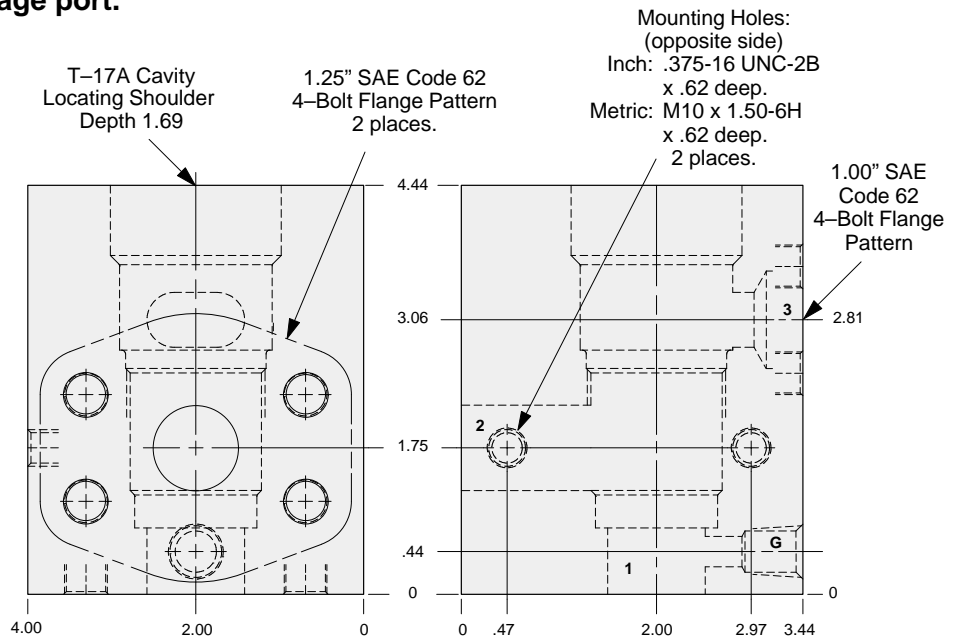

Mounting Hole Dimensions	Gage Port	ALUMINUM		DUCTILE IRON	
		Part Number	List Price	Part Number	List Price
Inch	.25 NPTF	HE5		HE5/S	
Metric	.25 BSPP	HE5/M		HE5/T	



LINE MOUNT BODIES



- Aluminum rated to 3000 psi.
- Ductile Iron rated to 5000 psi.

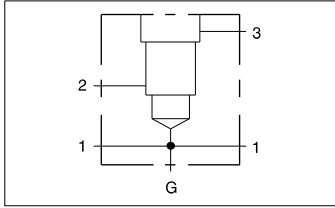

TYPICAL CARTRIDGES USED WITH THIS BODY

S3
T17A

RVGA - ***	Page 1.19
RSHC - ***	Page 2.07
SQHB - ***	Page 2.09
RSHE - ***	Page 2.11
SCGA - ***	Page 2.13
PBHB - ***	Page 3.07
PBHC - ***	Page 3.09

Instructions for ordering complete cartridge and body assemblies. Page v

Pressure ratings, material specifications. Page 11.02

SAE Specifications Page 11.03

Through port 1.00" SAE Code 61 flange port body with gage port.

T-17A Cavity Locating Shoulder Depth .91

1.00" SAE Code 61 4-Bolt Flange Pattern 3 places.

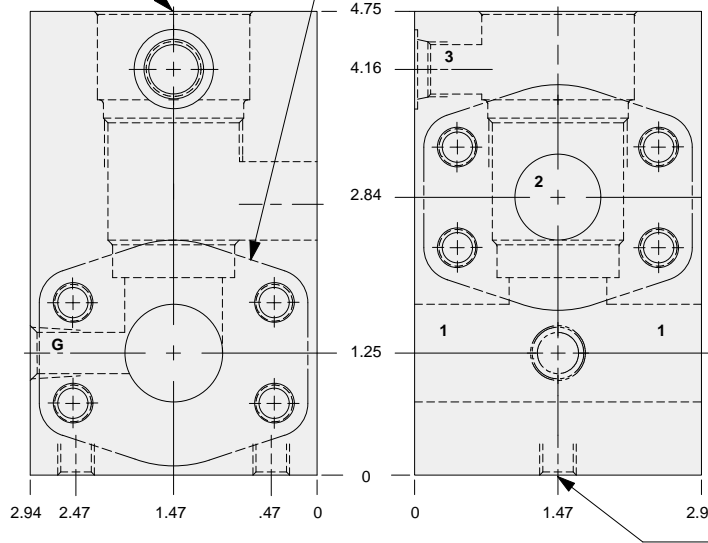

Mounting Holes:
Inch: .375-16 UNC-2B x .62 deep.
Metric: M10 x 1.50-6H x .62 deep.
2 places.

Mounting Hole Dimensions	Port 3	Gage Port	ALUMINUM		DUCTILE IRON	
			Part Number	List Price	Part Number	List Price
Inch	SAE-6	.25 NPTF	HHP		HHP/S	
Metric	.25 BSPP	.25 BSPP	HHP/M		HHP/T	

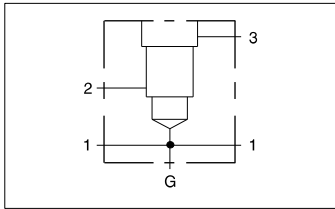

TYPICAL CARTRIDGES USED WITH THIS BODY

RVGA - ***	Page 1.19
RSHC - ***	Page 2.07
SQHB - ***	Page 2.09
RSHE - ***	Page 2.11
SCGA - ***	Page 2.13
PBHB - ***	Page 3.07
PBHC - ***	Page 3.09

Instructions for ordering complete cartridge and body assemblies. Page v

Pressure ratings, material specifications. Page 11.02

SAE Specifications Page 11.03

Through port 1.00" SAE Code 62 flange port body with gage port.

T-17A Cavity Locating Shoulder Depth .91

1.00" SAE Code 62 4-Bolt Flange Pattern 3 places.

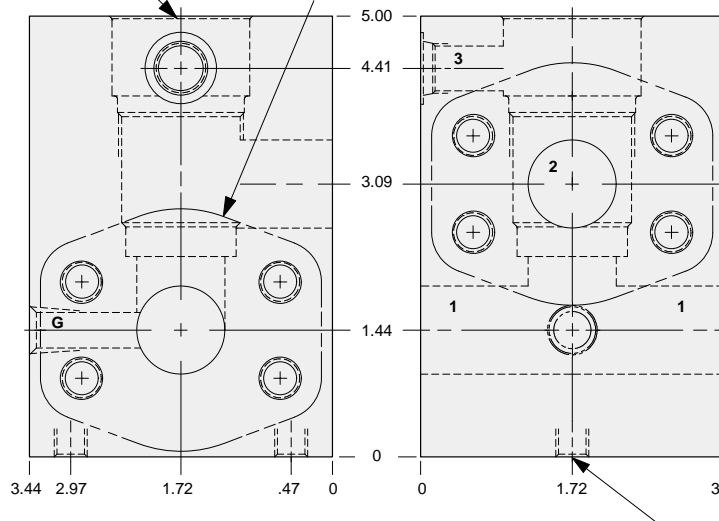

Mounting Holes:
Inch: .375-16 UNC-2B x .62 deep.
Metric: M10 x 1.50-6H x .62 deep.
2 places.

Mounting Hole Dimensions	Port 3	Gage Port	ALUMINUM		DUCTILE IRON	
			Part Number	List Price	Part Number	List Price
Inch	SAE-6	.25 NPTF	HH4		HH4/S	
Metric	.25 BSPP	.25 BSPP	HH4/M		HH4/T	



LINE MOUNT BODIES



- Aluminum rated to 3000 psi.
- Ductile Iron rated to 5000 psi.

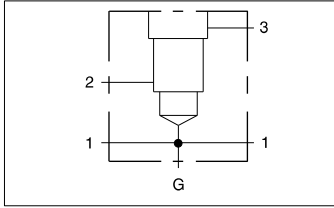

TYPICAL CARTRIDGES USED WITH THIS BODY

RVGA - ***	Page 1.19
RSHC - ***	Page 2.07
SQHB - ***	Page 2.09
RSHE - ***	Page 2.11
SCGA - ***	Page 2.13
PBHB - ***	Page 3.07
PBHC - ***	Page 3.09

Instructions for ordering complete cartridge and body assemblies. Page v

Pressure ratings, material specifications. Page 11.02

SAE Specifications Page 11.03

Through port 1.25" SAE Code 61 flange port body with gage port.

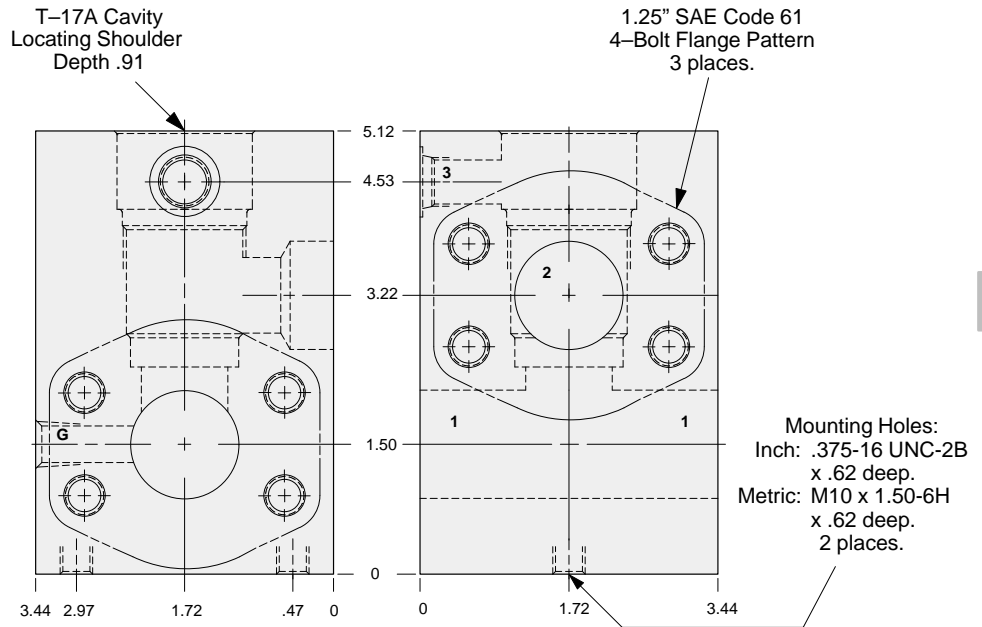

Mounting Hole Dimensions	Port 3	Gage Port	ALUMINUM		DUCTILE IRON	
			Part Number	List Price	Part Number	List Price
Inch	SAE-6	.25 NPTF	HHQ		HHQ/S	
Metric	.25 BSPP	.25 BSPP	HHQ/M		HHQ/T	

S3
T17A

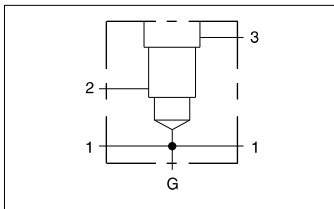

TYPICAL CARTRIDGES USED WITH THIS BODY

Instructions for ordering complete cartridge and body assemblies. Page v

Pressure ratings, material specifications. Page 11.02

SAE Specifications Page 11.03

Through port 1.25" SAE Code 62 flange port body with gage port.

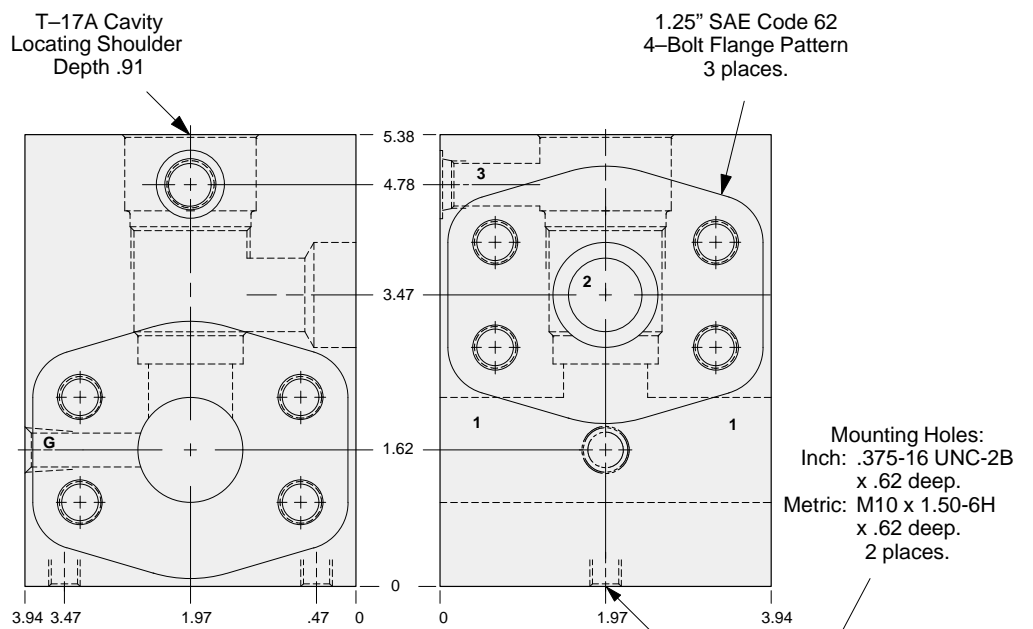

Mounting Hole Dimensions	Port 3	Gage Port	ALUMINUM		DUCTILE IRON	
			Part Number	List Price	Part Number	List Price
Inch	SAE-6	.25 NPTF	HH5		HH5/S	
Metric	.25 BSPP	.25 BSPP	HH5/M		HH5/T	



LINE MOUNT BODIES



- Aluminum rated to 3000 psi.
- Ductile Iron rated to 5000 psi.

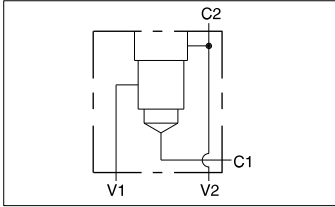

Nipple mount body for load control applications.

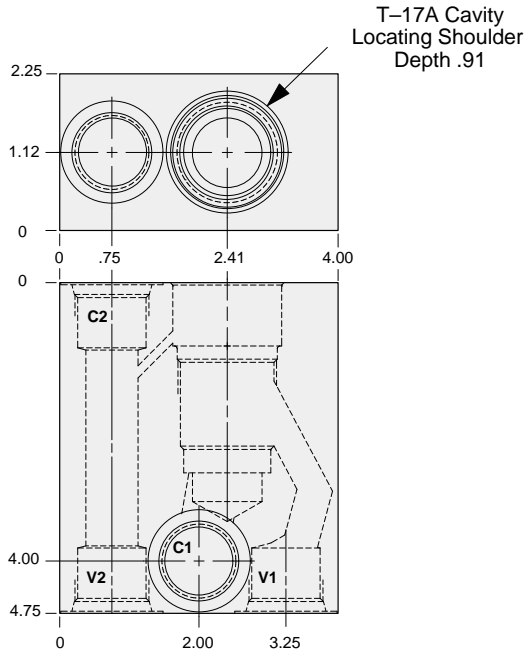

**TYPICAL CARTRIDGES
USED WITH THIS BODY**

**S3
T17A**

- CBGA - *** Page 4.11
- CBGG - *** Page 4.13
- CBGH - *** Page 4.15
- CKGB - *** Page 4.17

Instructions for ordering complete cartridge and body assemblies. Page v

Pressure ratings, material specifications. Page 11.02

Ports V1, V2, C1, C2	ALUMINUM		DUCTILE IRON	
	Part Number	List Price	Part Number	List Price
SAE-12	ZRN		ZRN/S	
.75 NPTF	ZTW		ZTW/S	



LINE MOUNT BODIES



- Aluminum rated to 3000 psi.
- Ductile Iron rated to 5000 psi.

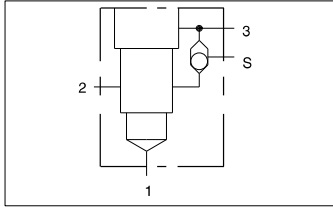

TYPICAL CARTRIDGES USED WITH THIS BODY

- CBGA - *** Page 4.11
- CBGG - *** Page 4.13
- CBGH - *** Page 4.15
- CKGB - *** Page 4.17

Instructions for ordering complete cartridge and body assemblies. Page v

Pressure ratings, material specifications. Page 11.02

90 degree body with shuttle for load control applications.

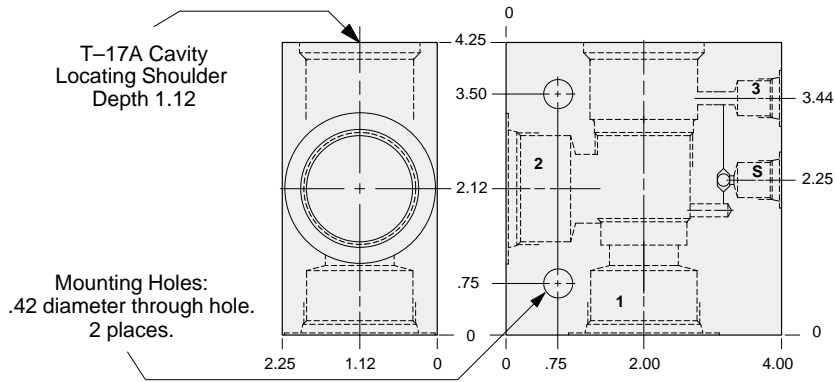

Ports 1 & 2	Ports S & 3	ALUMINUM		DUCTILE IRON	
		Part Number	List Price	Part Number	List Price
.75 NPTF	.25 NPTF	HGD		HGD/S	
1.00 NPTF	.25 NPTF	HGE		HGE/S	
1.25 NPTF	.25 NPTF	HGF		HGF/S	
SAE-12	SAE-6	HGL		HGL/S	
SAE-16	SAE-6	HGM		HGM/S	
SAE-20	SAE-6	HGN		HGN/S	
.75 BSPP	.25 BSPP	HGW		HGW/S	
1.00 BSPP	.25 BSPP	HGX		HGX/S	
1.25 BSPP	.25 BSPP	HGY		HGY/S	

S3
T17A

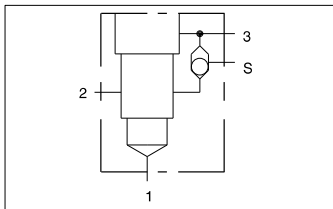

TYPICAL CARTRIDGES USED WITH THIS BODY

- CBGA - *** Page 4.11
- CBGG - *** Page 4.13
- CBGH - *** Page 4.15
- CKGB - *** Page 4.17

Instructions for ordering complete cartridge and body assemblies. Page v

Pressure ratings, material specifications. Page 11.02

SAE Specifications Page 11.03

90 degree 1.00" SAE Code 61 flange port body with shuttle for load control applications.

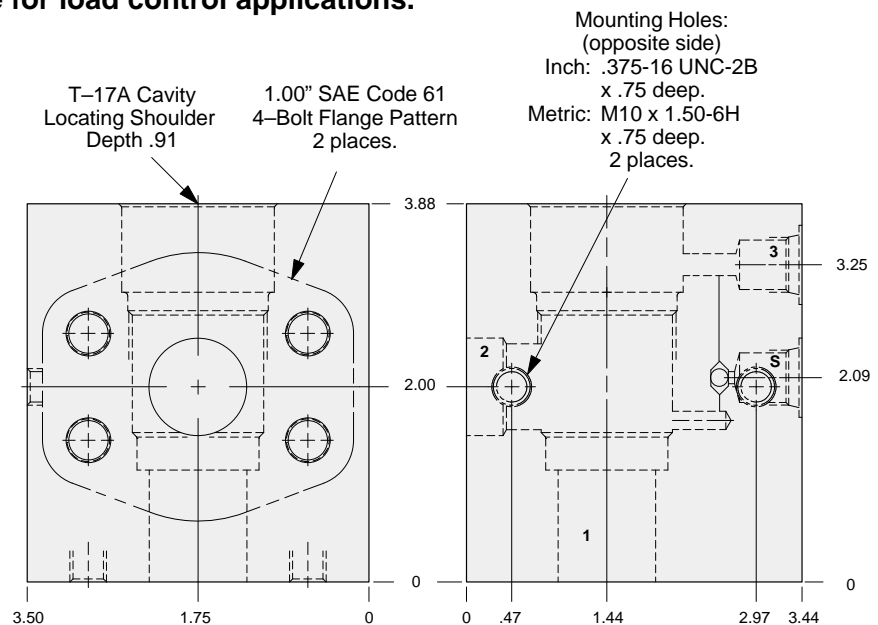

Mounting Hole Dimensions	Ports S & 3	ALUMINUM		DUCTILE IRON	
		Part Number	List Price	Part Number	List Price
Inch	SAE-6	HGP		HGP/S	
Metric	.25 BSPP	HGP/M		HGP/T	



LINE MOUNT BODIES



- Aluminum rated to 3000 psi.
- Ductile Iron rated to 5000 psi.

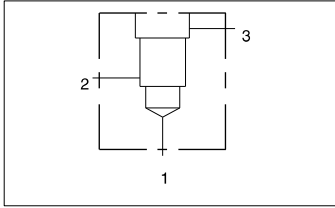

90 degree 1.25" SAE Code 61 flange port body with shuttle for load control applications.

TYPICAL CARTRIDGES USED WITH THIS BODY

S3
T17A

CBGA - ***	Page 4.11
CBGG - ***	Page 4.13
CBGH - ***	Page 4.15
CKGB - ***	Page 4.17

Instructions for ordering complete cartridge and body assemblies. Page v

Pressure ratings, material specifications. Page 11.02

SAE Specifications Page 11.03

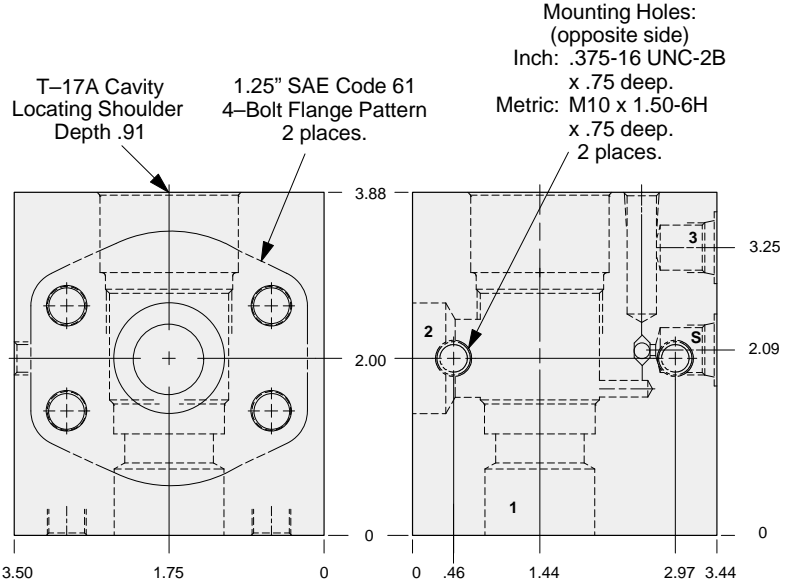

Mounting Hole Dimensions	Ports S & 3	ALUMINUM		DUCTILE IRON	
		Part Number	List Price	Part Number	List Price
Inch	SAE-6	HGQ		HGQ/S	
Metric	.25 BSPP	HGQ/M		HGQ/T	

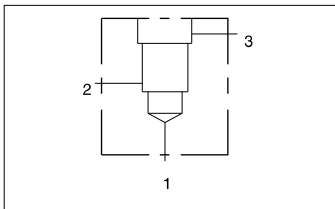

90 degree 1.25" SAE Code 62 flange port body with shuttle for load control applications.

TYPICAL CARTRIDGES USED WITH THIS BODY

CBGA - ***	Page 4.11
CBGG - ***	Page 4.13
CBGH - ***	Page 4.15
CKGB - ***	Page 4.17

Cartridge seal type determines shuttle valve seal type.

Instructions for ordering complete cartridge and body assemblies. Page v

Pressure ratings, material specifications. Page 11.02

SAE Specifications Page 11.03

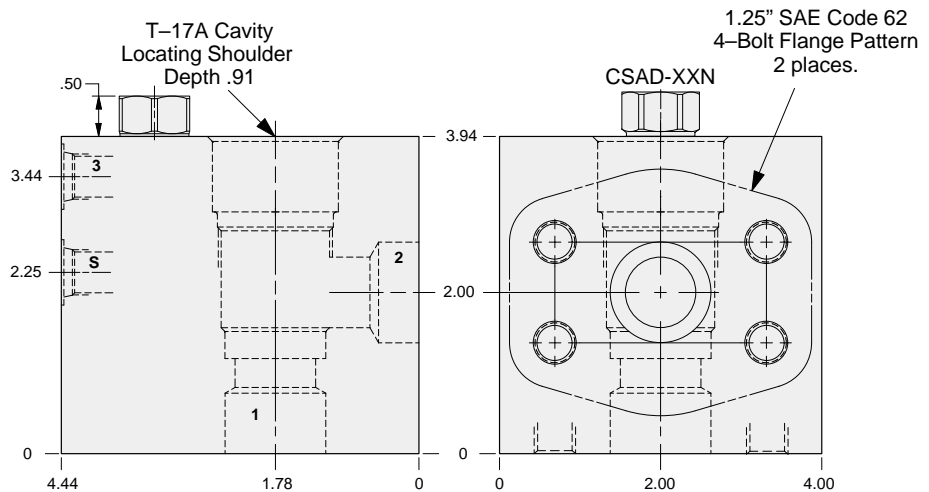

Mounting Hole Dimensions	Ports S & 3	ALUMINUM		DUCTILE IRON	
		Part Number	List Price	Part Number	List Price
Inch	SAE-6	HG5		HG5/S	
Metric	.25 BSPP	HG5/M		HG5/T	



LINE MOUNT BODIES



- Aluminum rated to 3000 psi.
- Ductile Iron rated to 5000 psi.

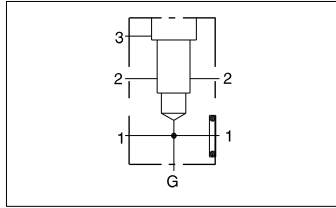

Sandwich mount through port 1.25" SAE Code 61 body with gage port.

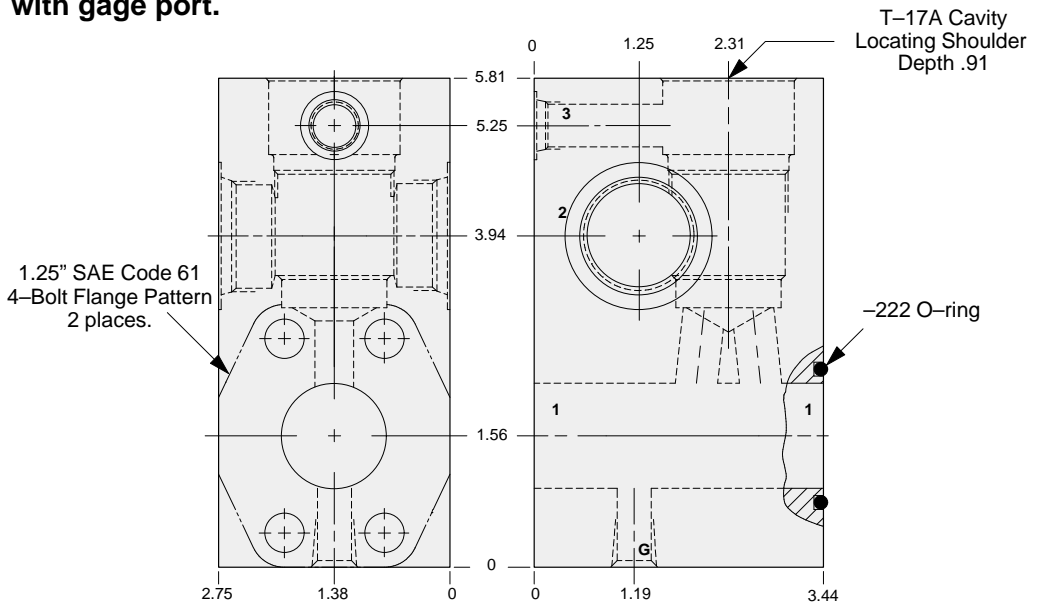

Mounting Hole Dimensions	Port 2	Port 3	Gage Port	ALUMINUM		DUCTILE IRON	
				Part Number	List Price	Part Number	List Price
Inch	1.00 NPTF	.25 NPTF	.25 NPTF	ZMQ		ZMQ/S	
Inch	SAE-16	SAE-6	.25 NPTF	ZMS		ZMS/S	
Metric	1.00 BSPP	.25 BSPP	.25 BSPP	ZMT/M		ZMT/T	

NOTE ZMQ body has 1.00" NPTF port in port 1 opposite O-ring.

S3
T17A

TYPICAL CARTRIDGES USED WITH THIS BODY

RVGA - ***	Page 1.19
RSHC - ***	Page 2.07
SQHB - ***	Page 2.09
RSHE - ***	Page 2.11
SCGA - ***	Page 2.13

Cartridge seal type determines O-ring type.

Instructions for ordering complete cartridge and body assemblies. Page v

Pressure ratings, material specifications. Page 11.02

SAE Specifications Page 11.03

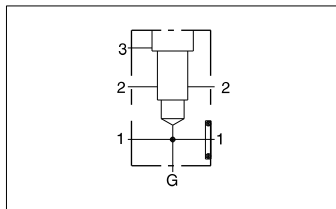

Sandwich mount through port 1.25" SAE Code 62 body with gage port.

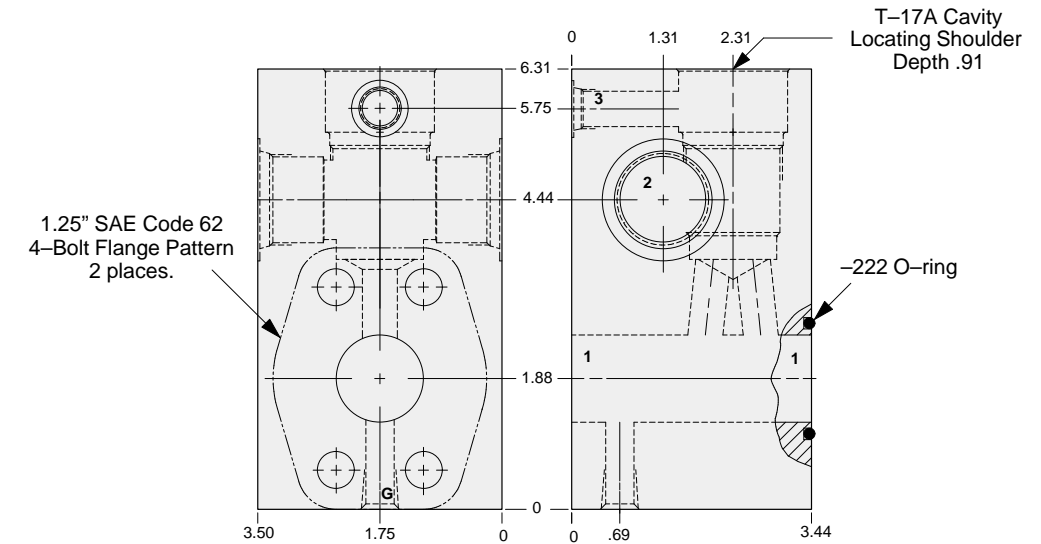

Mounting Hole Dimensions	Port 2	Port 3	Gage Port	ALUMINUM		DUCTILE IRON	
				Part Number	List Price	Part Number	List Price
Inch	1.00 NPTF	.25 NPTF	.25 NPTF	WXZ		WXZ/S	
Inch	SAE-16	SAE-6	.25 NPTF	WXY		WXY/S	
Metric	1.00 BSPP	.25 BSPP	.25 BSPP	WXX/M		WXX/T	

TYPICAL CARTRIDGES USED WITH THIS BODY

RVGA - ***	Page 1.19
RSHC - ***	Page 2.07
SQHB - ***	Page 2.09
RSHE - ***	Page 2.11
SCGA - ***	Page 2.13

Cartridge seal type determines O-ring type.

Instructions for ordering complete cartridge and body assemblies. Page v

Pressure ratings, material specifications. Page 11.02

SAE Specifications Page 11.03



LINE MOUNT BODIES



- Aluminum rated to 3000 psi.
- Ductile Iron rated to 5000 psi.

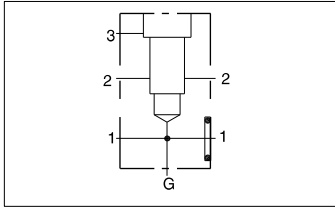

Sandwich mount through flange port 1.25" SAE Code 61 body with gage port.

1.25" SAE Code 61
4-Bolt Flange Pattern
3 places.
Port 1 through hole
Port 2 tapped hole.

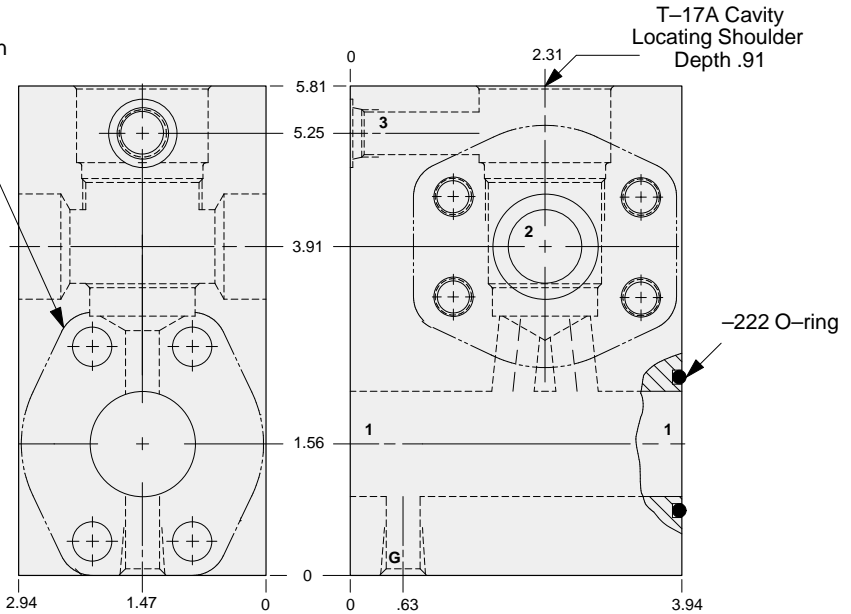

TYPICAL CARTRIDGES USED WITH THIS BODY

S3 T17A	RVGA - ***	Page 1.19
	RSHC - ***	Page 2.07
	SQHB - ***	Page 2.09
	RSHE - ***	Page 2.11
	SCGA - ***	Page 2.13

Cartridge seal type determines O-ring type.

Instructions for ordering complete cartridge and body assemblies. Page v

Pressure ratings, material specifications. Page 11.02

SAE Specifications Page 11.03

Mounting Hole Dimensions	Port 3	Gage Port	ALUMINUM		DUCTILE IRON	
			Part Number	List Price	Part Number	List Price
Inch	SAE-6	.25 NPTF	ZMV		ZMV/S	
Metric	.25 BSPP	.25 BSPP	ZMV/M		ZMV/T	

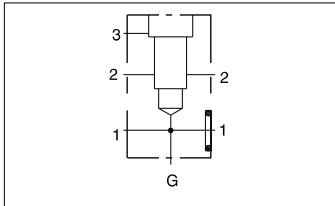

Sandwich mount through flange port 1.25" SAE Code 62 body with gage port.

1.25" SAE Code 62
4-Bolt Flange Pattern
3 places.
Port 1 through hole
Port 2 tapped hole.

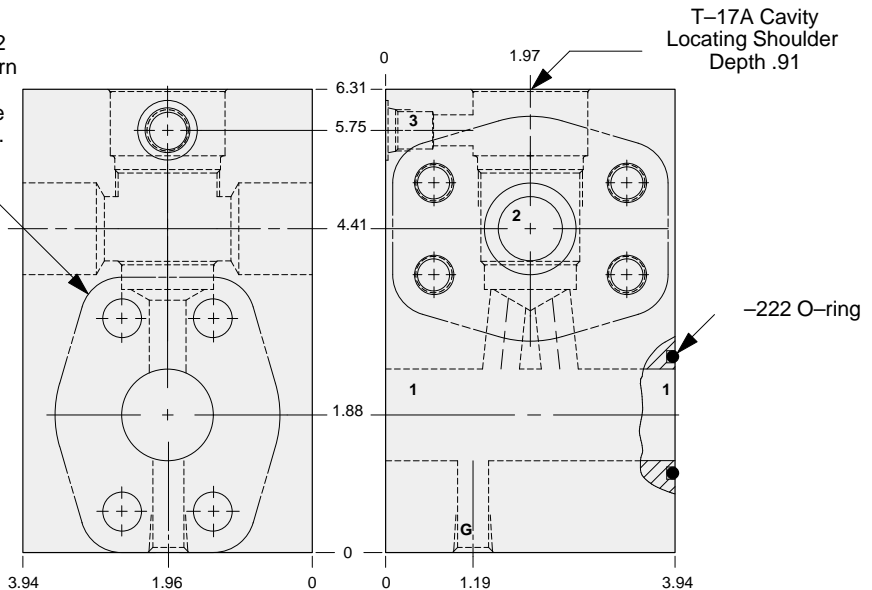

TYPICAL CARTRIDGES USED WITH THIS BODY

S3 T17A	RVGA - ***	Page 1.19
	RSHC - ***	Page 2.07
	SQHB - ***	Page 2.09
	RSHE - ***	Page 2.11
	SCGA - ***	Page 2.13

Cartridge seal type determines O-ring type.

Instructions for ordering complete cartridge and body assemblies. Page v

Pressure ratings, material specifications. Page 11.02

SAE Specifications Page 11.03

Mounting Hole Dimensions	Port 3	Gage Port	ALUMINUM		DUCTILE IRON	
			Part Number	List Price	Part Number	List Price
Inch	SAE-6	.25 NPTF	WYB		WYB/S	
Metric	.25 BSPP	.25 BSPP	WYB/M		WYB/T	



LINE MOUNT BODIES



- Aluminum rated to 3000 psi.
- Ductile Iron rated to 5000 psi.

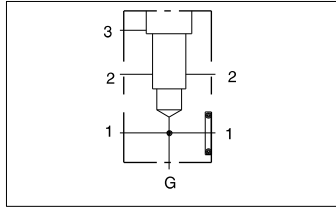

Flange mount through port 1.25" SAE Code 61 body with threaded outlet and gage port.

1.25" SAE Code 61
4-Bolt Flange Pattern
Counterbore .41 deep.

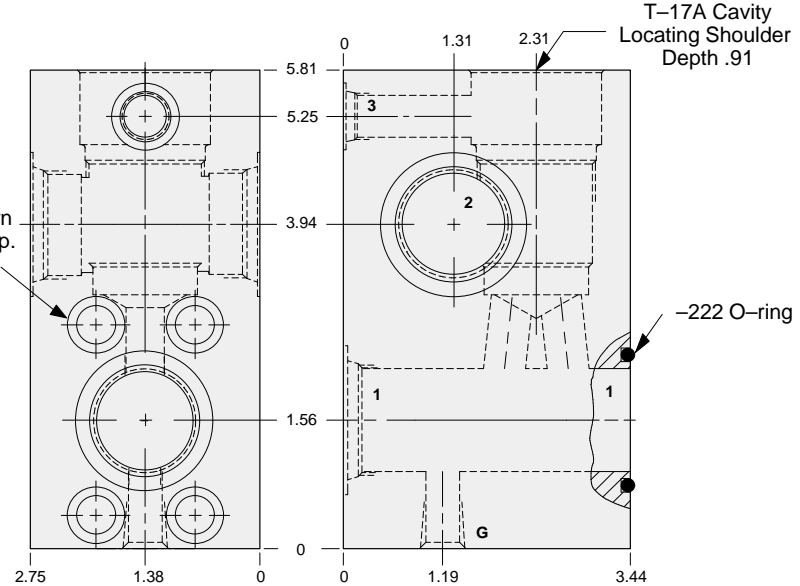

S3
T17A

TYPICAL CARTRIDGES USED WITH THIS BODY

RVGA - ***	Page 1.19
RSHC - ***	Page 2.07
SQHB - ***	Page 2.09
RSHE - ***	Page 2.11
SCGA - ***	Page 2.13

Cartridge seal type determines O-ring type.

Instructions for ordering complete cartridge and body assemblies. Page v

Pressure ratings, material specifications. Page 11.02

SAE Specifications Page 11.03

Mounting Hole Dimensions	Ports 1 & 2	Port 3	Gage Port	ALUMINUM		DUCTILE IRON	
				Part Number	List Price	Part Number	List Price
Inch	1.00 NPTF	.25 NPTF	.25 NPTF	WYT		WYT/S	
Inch	SAE-16	SAE-6	.25 NPTF	WYS		WYS/S	
Metric	1.00 BSPP	.25 BSPP	.25 BSPP	WYR/M		WYR/T	

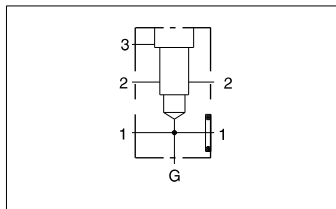

Flange mount through port 1.25" SAE Code 62 body with threaded outlet and gage port.

1.25" SAE Code 62
4-Bolt Flange Pattern
Counterbore .47 deep.

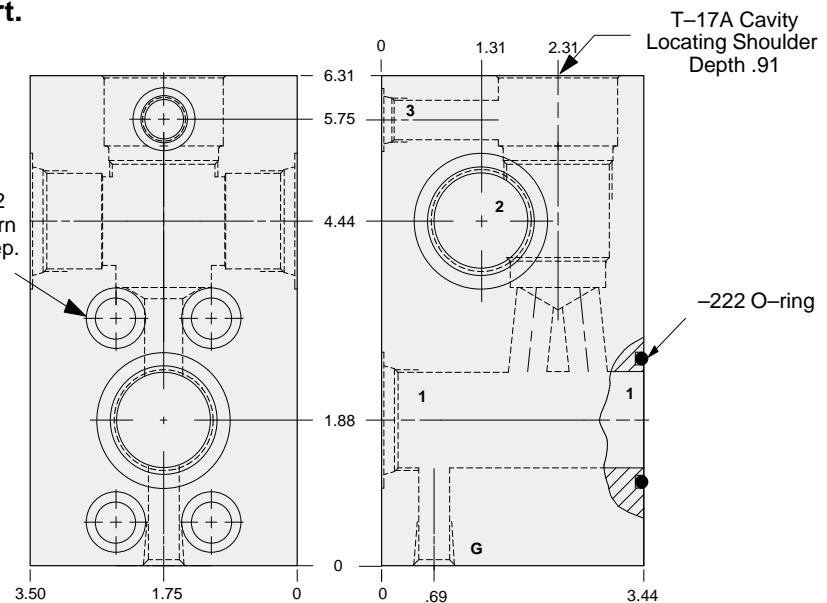

TYPICAL CARTRIDGES USED WITH THIS BODY

RVGA - ***	Page 1.19
RSHC - ***	Page 2.07
SQHB - ***	Page 2.09
RSHE - ***	Page 2.11
SCGA - ***	Page 2.13

Cartridge seal type determines O-ring type.

Instructions for ordering complete cartridge and body assemblies. Page v

Pressure ratings, material specifications. Page 11.02

SAE Specifications Page 11.03

Mounting Hole Dimensions	Ports 1 & 2	Port 3	Gage Port	ALUMINUM		DUCTILE IRON	
				Part Number	List Price	Part Number	List Price
Inch	1.00 NPTF	.25 NPTF	.25 NPTF	WXW		WXW/S	
Inch	SAE-16	SAE-6	.25 NPTF	WXV		WXV/S	
Metric	1.00 BSPP	.25 BSPP	.25 BSPP	WXU/M		WXU/T	



LINE MOUNT BODIES



- Aluminum rated to 3000 psi.
- Ductile Iron rated to 5000 psi.

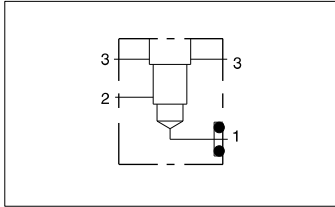

Direct mount .75" SAE Code 61 body with through pilot/drain port.

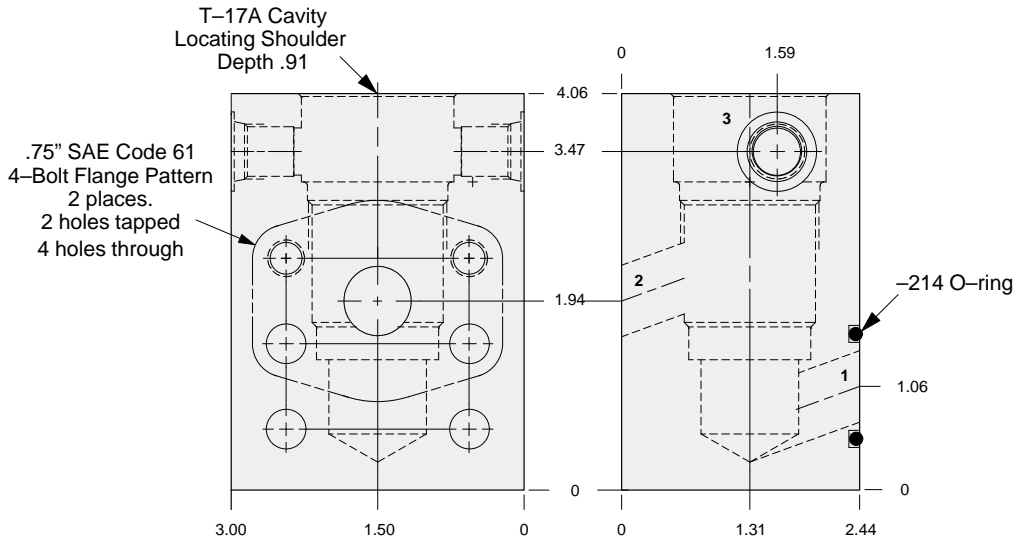

TYPICAL CARTRIDGES USED WITH THIS BODY

S3
T17A

RVGA - ***	Page 1.19
RSHC - ***	Page 2.07
SQHB - ***	Page 2.09
RSHE - ***	Page 2.11
SCGA - ***	Page 2.13
CBGA - ***	Page 4.11
CBGG - ***	Page 4.13
CBGH - ***	Page 4.15
CKGB - ***	Page 4.17
LOHC - ***	Page 9.09
LKHC - ***	Page 9.11
LPHC - ***	Page 9.13
LRHC - ***	Page 9.15
COHA - ***	Page 10.13

Cartridge seal type determines O-ring type.

Instructions for ordering complete cartridge and body assemblies. Page v

Pressure ratings, material specifications. Page 11.02

SAE Specifications Page 11.03

Mounting Hole Dimensions	Port 3	ALUMINUM		DUCTILE IRON	
		Part Number	List Price	Part Number	List Price
Inch	SAE-6	WGL		WGL/S	
Metric	.25 BSPP	WGL/M		WGL/T	

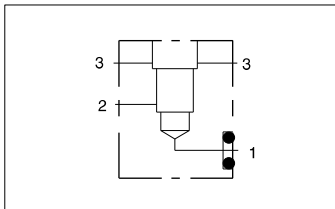

Direct mount .75" SAE Code 62 body with through pilot/drain port.

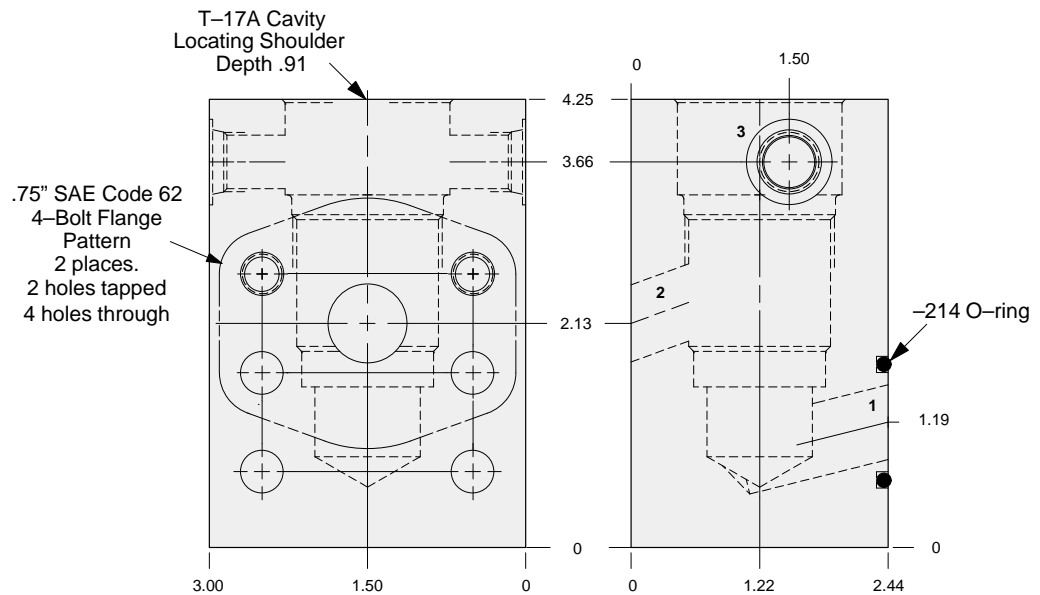

TYPICAL CARTRIDGES USED WITH THIS BODY

RVGA - ***	Page 1.19
RSHC - ***	Page 2.07
SQHB - ***	Page 2.09
RSHE - ***	Page 2.11
SCGA - ***	Page 2.13
CBGA - ***	Page 4.11
CBGG - ***	Page 4.13
CBGH - ***	Page 4.15
CKGB - ***	Page 4.17
LOHC - ***	Page 9.09
LKHC - ***	Page 9.11
LPHC - ***	Page 9.13
LRHC - ***	Page 9.15
COHA - ***	Page 10.13

Cartridge seal type determines O-ring type.

Instructions for ordering complete cartridge and body assemblies. Page v

Pressure ratings, material specifications. Page 11.02

SAE Specifications Page 11.03

Mounting Hole Dimensions	Port 3	ALUMINUM		DUCTILE IRON	
		Part Number	List Price	Part Number	List Price
Inch	SAE-6	WNG		WNG/S	
Metric	.25 BSPP	WNG/M		WNG/T	



LINE MOUNT BODIES



- Aluminum rated to 3000 psi.
- Ductile Iron rated to 5000 psi.

Direct mount 1.00" SAE Code 61 body with through pilot/drain port.

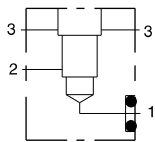

TYPICAL CARTRIDGES USED WITH THIS BODY

RVGA - ***	Page 1.19
RSHC - ***	Page 2.07
SQHB - ***	Page 2.09
RSHE - ***	Page 2.11
SCGA - ***	Page 2.13
CBGA - ***	Page 4.11
CBGG - ***	Page 4.13
CBGH - ***	Page 4.15
CKGB - ***	Page 4.17
LOHC - ***	Page 9.09
LKHC - ***	Page 9.11
LPHC - ***	Page 9.13
LRHC - ***	Page 9.15
COHA - ***	Page 10.13

Cartridge seal type determines O-ring type.

Instructions for ordering complete cartridge and body assemblies. Page v

Pressure ratings, material specifications. Page 11.02

SAE Specifications Page 11.03

1.00" SAE Code 61
4-Bolt Flange Pattern
2 places.
2 holes tapped
4 holes through

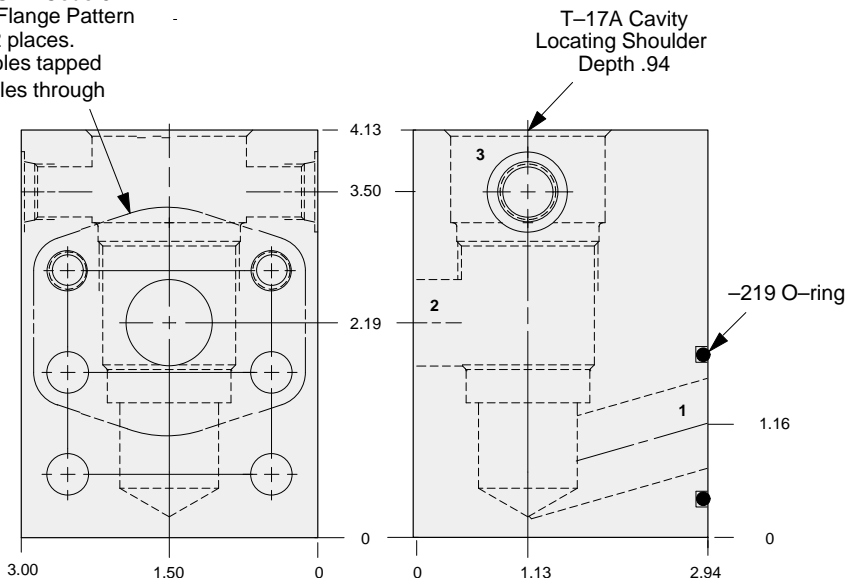

Mounting Hole Dimensions	Port 3	ALUMINUM		DUCTILE IRON	
		Part Number	List Price	Part Number	List Price
Inch	SAE-6	ZNW		ZNW/S	
Metric	.25 BSPP	ZNW/M		ZNW/T	

S3
T17A

Direct mount 1.00" SAE Code 62 body with through pilot/drain port.

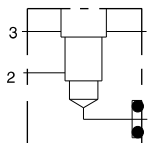

TYPICAL CARTRIDGES USED WITH THIS BODY

RVGA - ***	Page 1.19
RSHC - ***	Page 2.07
SQHB - ***	Page 2.09
RSHE - ***	Page 2.11
SCGA - ***	Page 2.13
CBGA - ***	Page 4.11
CBGG - ***	Page 4.13
CBGH - ***	Page 4.15
CKGB - ***	Page 4.17
LOHC - ***	Page 9.09
LKHC - ***	Page 9.11
LPHC - ***	Page 9.13
LRHC - ***	Page 9.15
COHA - ***	Page 10.13

Cartridge seal type determines O-ring type.

Instructions for ordering complete cartridge and body assemblies. Page v

Pressure ratings, material specifications. Page 11.02

SAE Specifications Page 11.03

1.00" SAE Code 62
4-Bolt Flange Pattern
2 places.
2 holes tapped
4 holes through

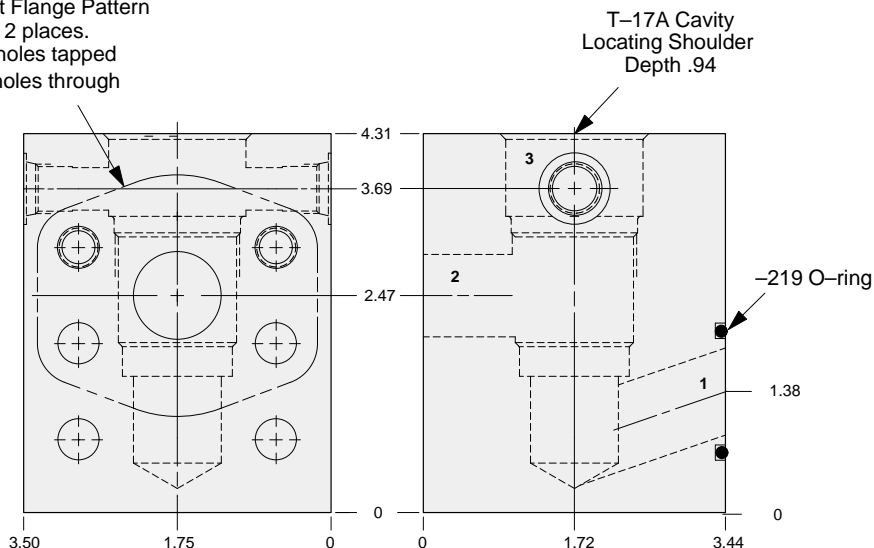

Mounting Hole Dimensions	Port 3	ALUMINUM		DUCTILE IRON	
		Part Number	List Price	Part Number	List Price
Inch	SAE-6	ZDR		ZDR/S	
Metric	.25 BSPP	ZDR/M		ZDR/T	



LINE MOUNT BODIES



- Aluminum rated to 3000 psi.
- Ductile Iron rated to 5000 psi.

Direct mount 1.25" SAE Code 61 body with through pilot/drain port.

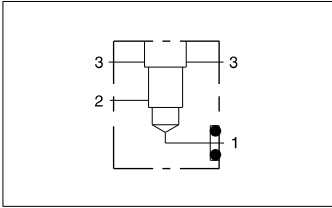

1.25" SAE Code 61
4-Bolt Flange Pattern
2 places.
2 holes tapped
4 holes through

T-17A Cavity
Locating Shoulder
Depth .94

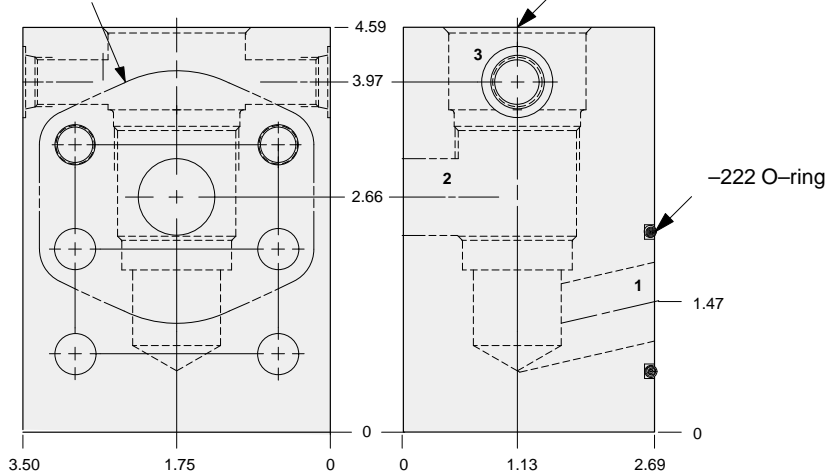

TYPICAL CARTRIDGES USED WITH THIS BODY

S3
T17A

RVGA - ***	Page 1.19
RSHC - ***	Page 2.07
SQHB - ***	Page 2.09
RSHE - ***	Page 2.11
SCGA - ***	Page 2.13
CBGA - ***	Page 4.11
CBGG - ***	Page 4.13
CBGH - ***	Page 4.15
CKGB - ***	Page 4.17
LOHC - ***	Page 9.09
LKHC - ***	Page 9.11
LPHC - ***	Page 9.13
LRHC - ***	Page 9.15
COHA - ***	Page 10.13

Cartridge seal type determines O-ring type.

Instructions for ordering complete cartridge and body assemblies. Page v

Pressure ratings, material specifications. Page 11.02

SAE Specifications Page 11.03

Mounting Hole Dimensions	Port 3	ALUMINUM		DUCTILE IRON	
		Part Number	List Price	Part Number	List Price
Inch	SAE-6	ZJY		ZJY/S	
Metric	.25 BSPP	ZJY/M		ZJY/T	

Two cavity body for flow control applications.

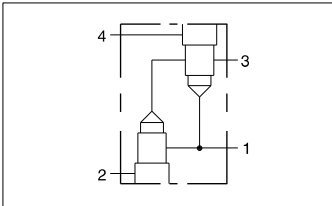

TYPICAL CARTRIDGES USED WITH THIS BODY

FREA - *** Page 6.03

Instructions for ordering complete cartridge and body assemblies. Page v

Pressure ratings, material specifications. Page 11.02

T-17A Cavity
Locating Shoulder
Depth 1.19
2 places.

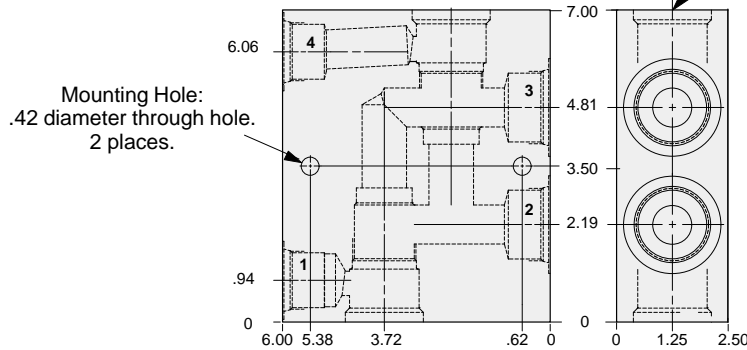

Ports 1, 4	Ports 2, 3	ALUMINUM		DUCTILE IRON	
		Part Number	List Price	Part Number	List Price
.75 NPTF	.75 NPTF	VXB		VXB/S	
1.00 NPTF	1.00 NPTF	VXC		VXC/S	
1.00 NPTF	1.25 NPTF	VXD		VXD/S	
SAE-12	SAE-12	VXF		VXF/S	
SAE-16	SAE-16	VXG		VXG/S	
SAE-16	SAE-20	VXH		VXH/S	
.75 BSPP	.75 BSPP	VXJ		VXJ/S	
1.00 BSPP	1.00 BSPP	VXK		VXK/S	
1.00 BSPP	1.25 BSPP	VXL		VXL/S	



LINE MOUNT BODIES



- Aluminum rated to 3000 psi.
- Ductile Iron rated to 5000 psi.

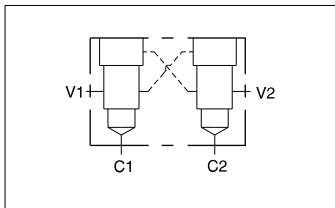

Two cavity 90 degree cross-piloted body for load control applications.

T-17A Cavity
Locating Shoulder
Depth .91
2 places.

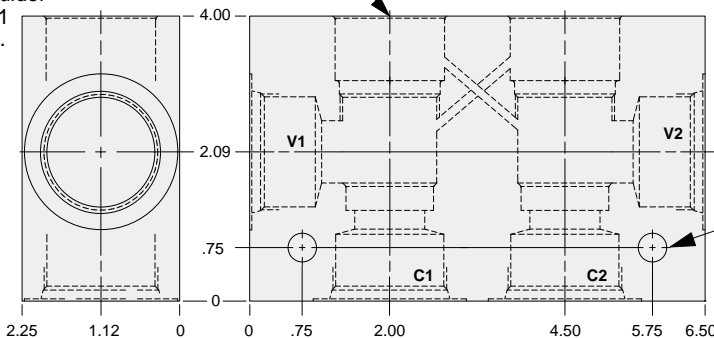

Mounting Hole:
.42 diameter
through hole.
2 places.

TYPICAL CARTRIDGES USED WITH THIS BODY

- CBGA - *** Page 4.11
CBGG - *** Page 4.13
CBGH - *** Page 4.15
CKGB - *** Page 4.17

Instructions for ordering complete cartridge and body assemblies. Page v

Pressure ratings, material specifications. Page 11.02

Ports C1, C2 V1, V2	ALUMINUM		DUCTILE IRON	
	Part Number	List Price	Part Number	List Price
.75 NPTF	YJD		YJD/S	
1.00 NPTF	YJE		YJE/S	
1.25 NPTF	YJF		YJF/S	
SAE-12	YJL		YJL/S	
SAE-16	YJM		YJM/S	
SAE-20	YJN		YJN/S	
.75 BSPP	YJW		YJW/S	
1.00 BSPP	YJX		YJX/S	
1.25 BSPP	YJY		YJY/S	

S3
T17A

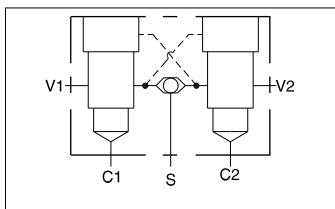

Two cavity 90 degree cross-piloted body with shuttle for load control applications.

T-17A Cavity
Locating Shoulder
Depth .91
2 places.

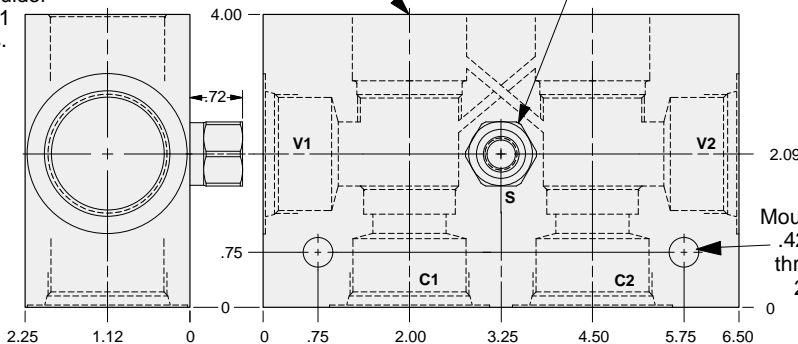

Mounting Holes:
.42 diameter
through hole.
2 places.

TYPICAL CARTRIDGES USED WITH THIS BODY

- CBGA - *** Page 4.11
CBGG - *** Page 4.13
CBGH - *** Page 4.15
CKGB - *** Page 4.17

Cartridge seal type determines shuttle valve seal type.

Instructions for ordering complete cartridge and body assemblies. Page v

Pressure ratings, material specifications. Page 11.02

Ports C1, C2 V1, V2	Shuttle Cartridge	Port S	ALUMINUM		DUCTILE IRON	
			Part Number	List Price	Part Number	List Price
.75 NPTF	CSAA - EXN	SAE-4	YKD		YKD/S	
1.00 NPTF	CSAA - EXN	SAE-4	YKE		YKE/S	
1.25 NPTF	CSAA - EXN	SAE-4	YKF		YKF/S	
SAE-12	CSAA - EXN	SAE-4	YKL		YKL/S	
SAE-16	CSAA - EXN	SAE-4	YKM		YKM/S	
SAE-20	CSAA - EXN	SAE-4	YKN		YKN/S	
.75 BSPP	CSAA - BXN	.25 BSPP	YKW		YKW/S	
1.00 BSPP	CSAA - BXN	.25 BSPP	YKX		YKX/S	
1.25 BSPP	CSAA - BXN	.25 BSPP	YKY		YKY/S	



LINE MOUNT BODIES



- Aluminum rated to 3000 psi.
- Ductile Iron rated to 5000 psi.

Two cavity cross-piloted 1.00" SAE Code 61 body for load control applications.

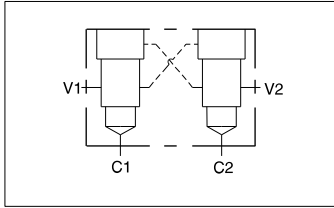

TYPICAL CARTRIDGES USED WITH THIS BODY

S3 T17A	CBGA - ***	Page 4.11
	CBGG - ***	Page 4.13
	CBGH - ***	Page 4.15
	CKGB - ***	Page 4.17

Instructions for ordering complete cartridge and body assemblies. Page v

Pressure ratings, material specifications. Page 11.02

SAE Specifications Page 11.03

1.00" SAE Code 61
4-Bolt Flange Pattern
4 places.

Mounting Holes:
(opposite side)
Inch: .375-16 UNC-2B
x .62 DP.
Metric: M10 x 1.50-6H
x .62 DP.
2 places.

T-17A Cavity
Locating Shoulder
Depth .94
2 places.

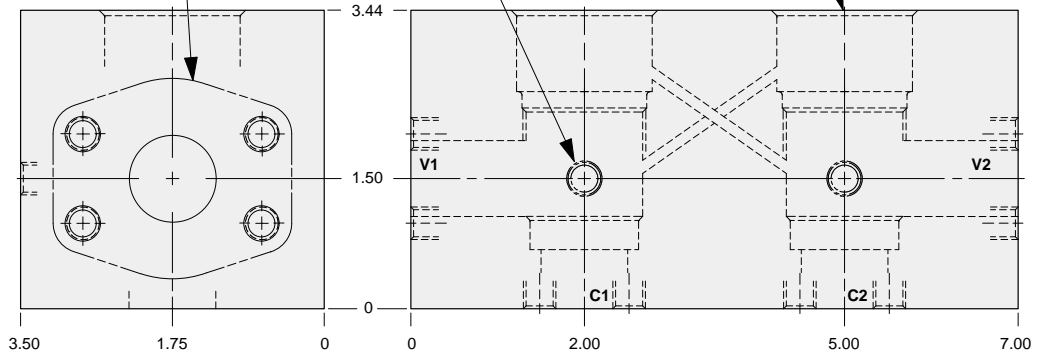

Mounting Hole Dimensions	ALUMINUM		DUCTILE IRON	
	Part Number	List Price	Part Number	List Price
Inch	YJP		YJP/S	
Metric	YJP/M		YJP/T	

Two cavity cross-piloted 1.25" SAE Code 61 body for load control applications.

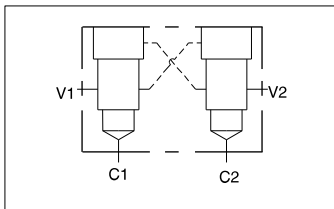

TYPICAL CARTRIDGES USED WITH THIS BODY

S3 T17A	CBGA - ***	Page 4.11
	CBGG - ***	Page 4.13
	CBGH - ***	Page 4.15
	CKGB - ***	Page 4.17

Instructions for ordering complete cartridge and body assemblies. Page v

Pressure ratings, material specifications. Page 11.02

SAE Specifications Page 11.03

1.25" SAE Code 61
4-Bolt Flange Pattern
4 places.

Mounting Holes:
(opposite side)
Inch: .375-16 UNC-2B
x .62 DP.
Metric: M10 x 1.50-6H
x .62 DP.
2 places.

T-17A Cavity
Locating Shoulder
Depth .94
2 places.

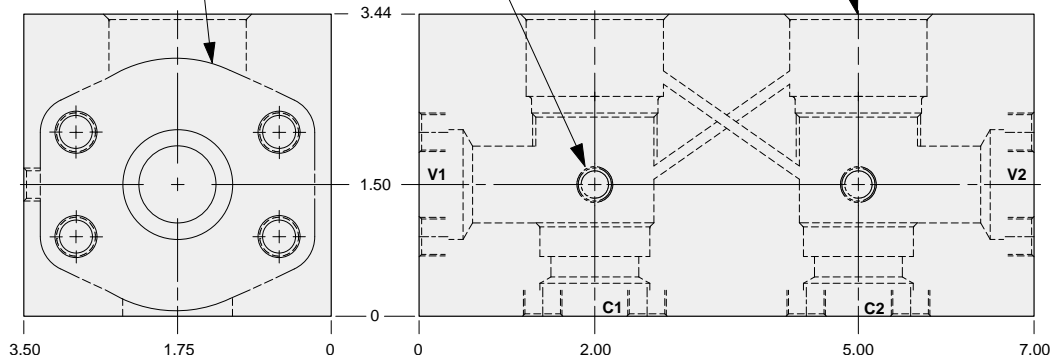

Mounting Hole Dimensions	ALUMINUM		DUCTILE IRON	
	Part Number	List Price	Part Number	List Price
Inch	YJQ		YJQ/S	
Metric	YJQ/M		YJQ/T	



LINE MOUNT BODIES



- Aluminum rated to 3000 psi.
- Ductile Iron rated to 5000 psi.

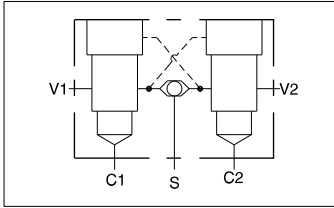

Two cavity cross-piloted 1.00" SAE Code 61 body with shuttle for load control applications.

TYPICAL CARTRIDGES USED WITH THIS BODY

- CBGA - *** Page 4.11
- CBGG - *** Page 4.13
- CBGH - *** Page 4.15
- CKGB - *** Page 4.17

Cartridge seal type determines shuttle valve seal type.

Instructions for ordering complete cartridge and body assemblies. Page v

Pressure ratings, material specifications. Page 11.02

SAE Specifications Page 11.03

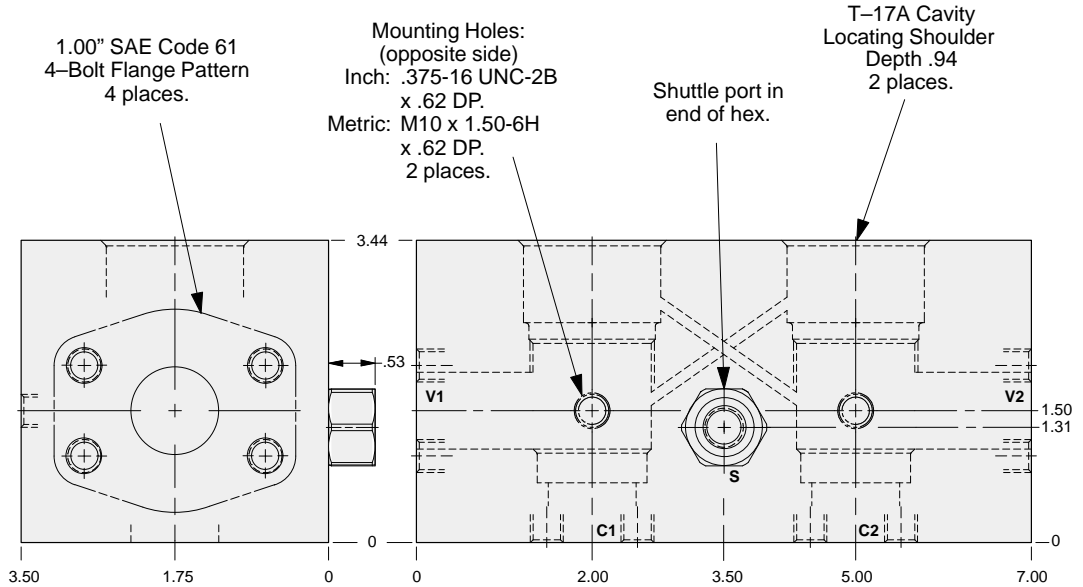

S3
T17A

Mounting Hole Dimensions	Shuttle Cartridge	Port S	ALUMINUM		DUCTILE IRON	
			Part Number	List Price	Part Number	List Price
Inch	CSAA - EXN	SAE-6	YKP		YKP/S	
Metric	CSAA - BXN	.25 BSPP	YKP/M		YKP/T	

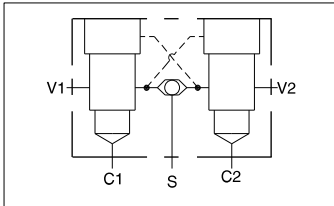

Two cavity cross-piloted 1.25" SAE Code 61 body with shuttle for load control applications.

TYPICAL CARTRIDGES USED WITH THIS BODY

- CBGA - *** Page 4.11
- CBGG - *** Page 4.13
- CBGH - *** Page 4.15
- CKGB - *** Page 4.17

Cartridge seal type determines shuttle valve seal type.

Instructions for ordering complete cartridge and body assemblies. Page v

Pressure ratings, material specifications. Page 11.02

SAE Specifications Page 11.03

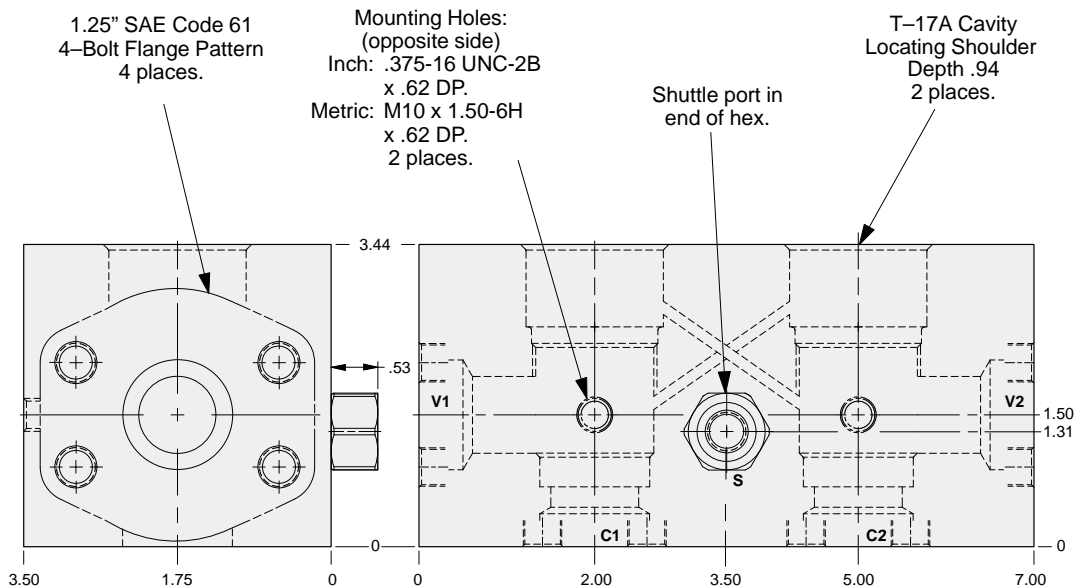

Mounting Hole Dimensions	Shuttle Cartridge	Port S	ALUMINUM		DUCTILE IRON	
			Part Number	List Price	Part Number	List Price
Inch	CSAA - EXN	SAE-6	YKQ		YKQ/S	
Metric	CSAA - BXN	.25 BSPP	YKQ/M		YKQ/T	



LINE MOUNT BODIES



- Aluminum rated to 3000 psi.
- Ductile Iron rated to 5000 psi.

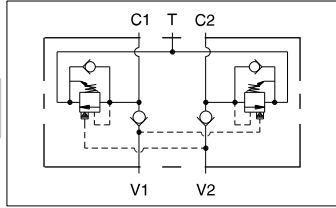
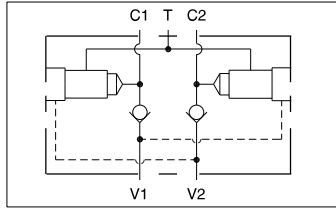

TYPICAL CARTRIDGES USED WITH THIS BODY

- CBGA - *** Page 4.11
 CBGG - *** Page 4.13
 CBGH - *** Page 4.15

Cartridge seal type determines check valve seal type.

Instructions for ordering complete cartridge and body assemblies. Page v

Pressure ratings, material specifications. Page 11.02

Two cavity dual load control body with checks.

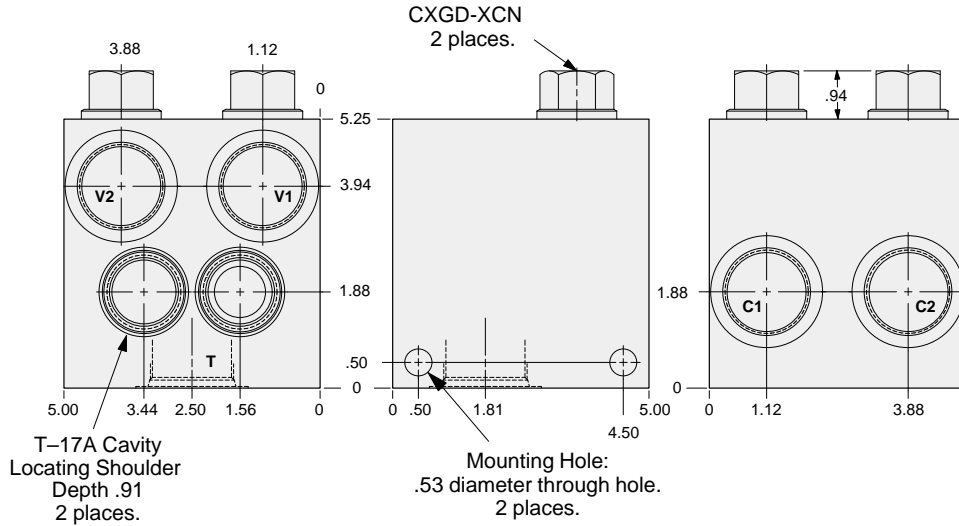

Ports C1, C2, & V1, V2	Port T	ALUMINUM		DUCTILE IRON	
		Part Number	List Price	Part Number	List Price
1.00 NPTF	1.25 NPTF	HME		HME/S	
1.25 NPTF	1.25 NPTF	HMF		HMF/S	
SAE-16	SAE-20	HMM		HMM/S	
SAE-20	SAE-20	HMN		HMN/S	
1.00 BSPP	1.25 BSPP	HMX		HMX/S	
1.25 BSPP	1.25 BSPP	HMY		HMY/S	

Discharge oil returns to tank through port T.

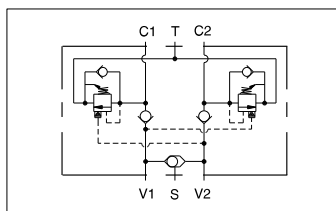
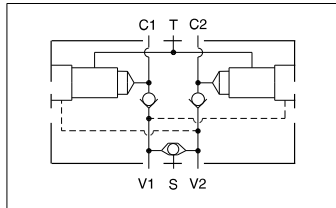

TYPICAL CARTRIDGES USED WITH THIS BODY

- CBGA - *** Page 4.11
 CBGG - *** Page 4.13
 CBGH - *** Page 4.15

Cartridge seal type determines check valve seal type.

Instructions for ordering complete cartridge and body assemblies. Page v

Pressure ratings, material specifications. Page 11.02

Two cavity dual load control body with checks and shuttle.

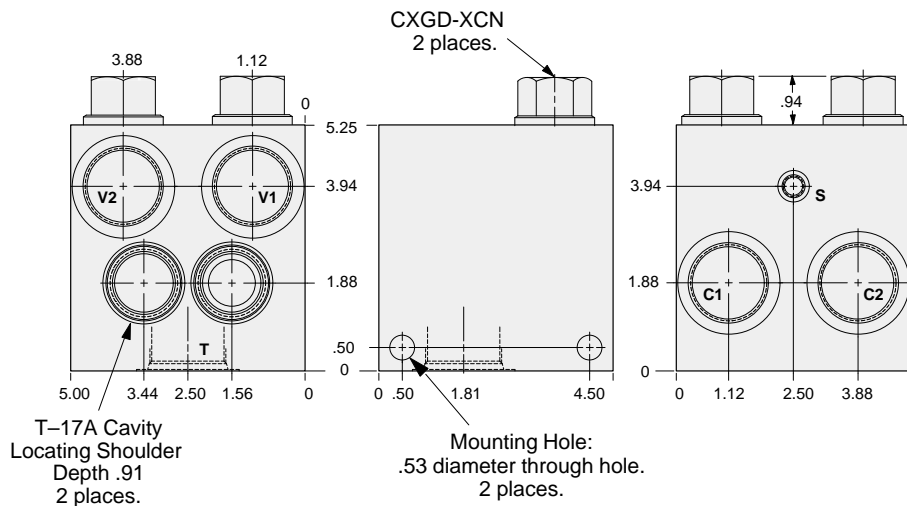

Ports C1, C2, & V1, V2	Port S	Port T	ALUMINUM		DUCTILE IRON	
			Part Number	List Price	Part Number	List Price
1.00 NPTF	.25 NPTF	1.25 NPTF	HNE		HNE/S	
1.25 NPTF	.25 NPTF	1.25 NPTF	HNF		HNF/S	
SAE-16	SAE-4	SAE-20	HNM		HNM/S	
SAE-20	SAE-4	SAE-20	HNN		HNN/S	
1.00 BSPP	.25 BSPP	1.25 BSPP	HNX		HNX/S	
1.25 BSPP	.25 BSPP	1.25 BSPP	HNY		HNY/S	

Discharge oil returns to tank through port T.



LINE MOUNT BODIES



- Aluminum rated to 3000 psi.
- Ductile Iron rated to 5000 psi.

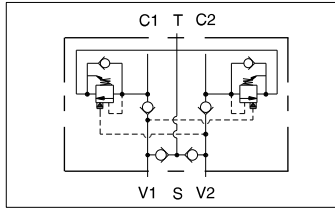
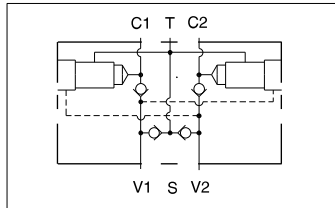

TYPICAL CARTRIDGES USED WITH THIS BODY

- CBGA - *** Page 4.11
 CBGG - *** Page 4.13
 CBGH - *** Page 4.15

Cartridge seal type determines check valve seal type.

Instructions for ordering complete cartridge and body assemblies. Page v

Pressure ratings, material specifications. Page 11.02

SAE Specifications Page 11.03

Two cavity dual load control body with make-up checks.

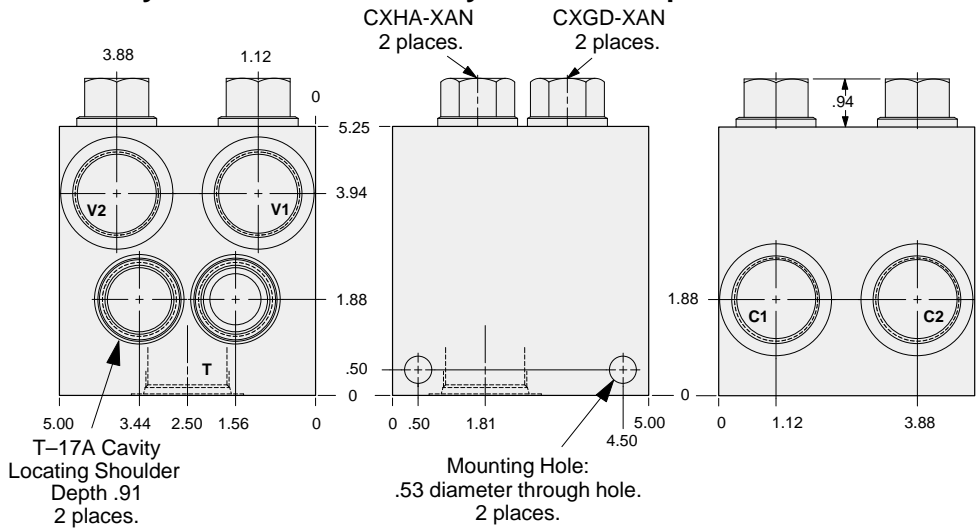

Ports C1, C2, & V1, V2	Port T	ALUMINUM		DUCTILE IRON	
		Part Number	List Price	Part Number	List Price
1.00 NPTF	1.25 NPTF	HPE		HPE/S	
1.25 NPTF	1.25 NPTF	HPF		HPF/S	
SAE-16	SAE-20	HPM		HPM/S	
SAE-20	SAE-20	HPN		HPN/S	
1.00 BSPP	1.25 BSPP	HPX		HPX/S	
1.25 BSPP	1.25 BSPP	HPY		HPY/S	

Discharge oil returns to tank through directional valve or port T.

S3
T17A

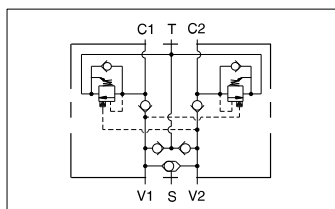
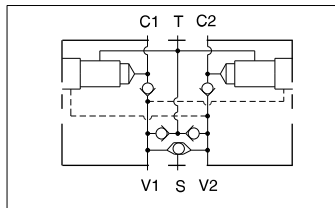

TYPICAL CARTRIDGES USED WITH THIS BODY

- CBGA - *** Page 4.11
 CBGG - *** Page 4.13
 CBGH - *** Page 4.15

Cartridge seal type determines check valve seal type.

Instructions for ordering complete cartridge and body assemblies. Page v

Pressure ratings, material specifications. Page 11.02

SAE Specifications Page 11.03

Two cavity dual load control body with make-up checks and shuttle.

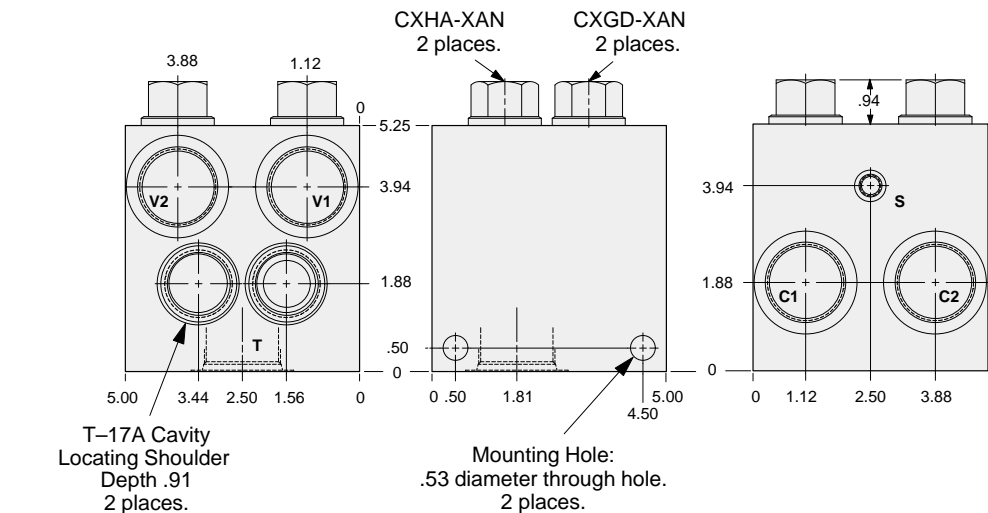

Ports C1, C2, & V1, V2	Port S	Port T	ALUMINUM		DUCTILE IRON	
			Part Number	List Price	Part Number	List Price
1.00 NPTF	.25 NPTF	1.25 NPTF	HQE		HQE/S	
1.25 NPTF	.25 NPTF	1.25 NPTF	HQF		HQF/S	
SAE-16	SAE-4	SAE-20	HQM		HQM/S	
SAE-20	SAE-4	SAE-20	HQN		HQN/S	
1.00 BSPP	.25 BSPP	1.25 BSPP	HQX		HQX/S	
1.25 BSPP	.25 BSPP	1.25 BSPP	HQY		HQY/S	

Discharge oil returns to tank through directional valve or port T.



LINE MOUNT BODIES



- Aluminum rated to 3000 psi.
- Ductile Iron rated to 5000 psi.

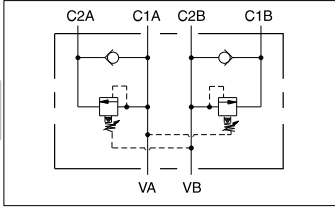
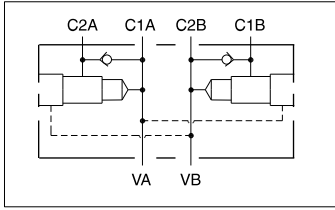

TYPICAL CARTRIDGES USED WITH THIS BODY

RSHC - *** Page 2.07
SQHB - *** Page 2.09

Instructions for ordering complete cartridge and body assemblies. Page v

Pressure ratings, material specifications. Page 11.02

Two cavity dual sequence body with reverse free flow checks.

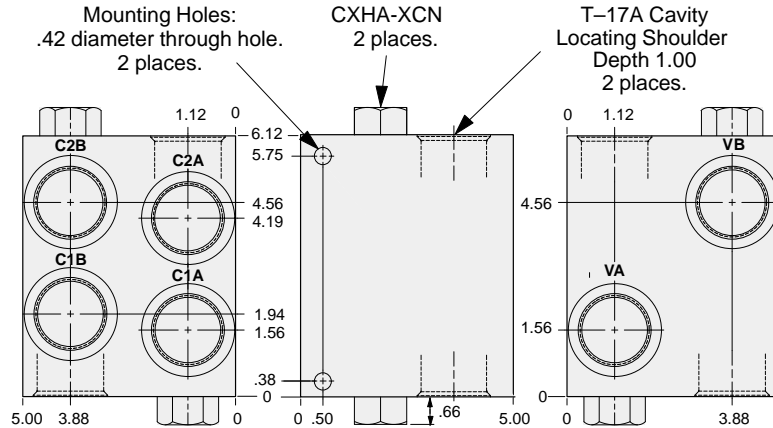

All Ports	ALUMINUM		DUCTILE IRON	
	Part Number	List Price	Part Number	List Price
.75 NPTF	H8D		H8D/S	
1.00 NPTF	H8E		H8E/S	
1.25 NPTF	H8F		H8F/S	
SAE-12	H8L		H8L/S	
SAE-16	H8M		H8M/S	
SAE-20	H8N		H8N/S	
.75 BSPP	H8W		H8W/S	
1.00 BSPP	H8X		H8X/S	
1.25 BSPP	H8Y		H8Y/S	

S3
T17A



LINE MOUNT BODIES



- Aluminum rated to 3000 psi.
- Ductile Iron rated to 5000 psi.

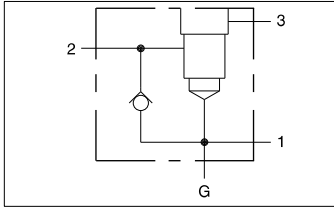

TYPICAL CARTRIDGES USED WITH THIS BODY

- RSHC - *** Page 2.07
 SQHB - *** Page 2.09
 RSHE - *** Page 2.11

Cartridge seal type determines check valve seal type.

Instructions for ordering complete cartridge and body assemblies. Page v

Pressure ratings, material specifications. Page 11.02

1.00" SAE Code 62 flange port body with reverse free flow check and gage port for sequence applications.

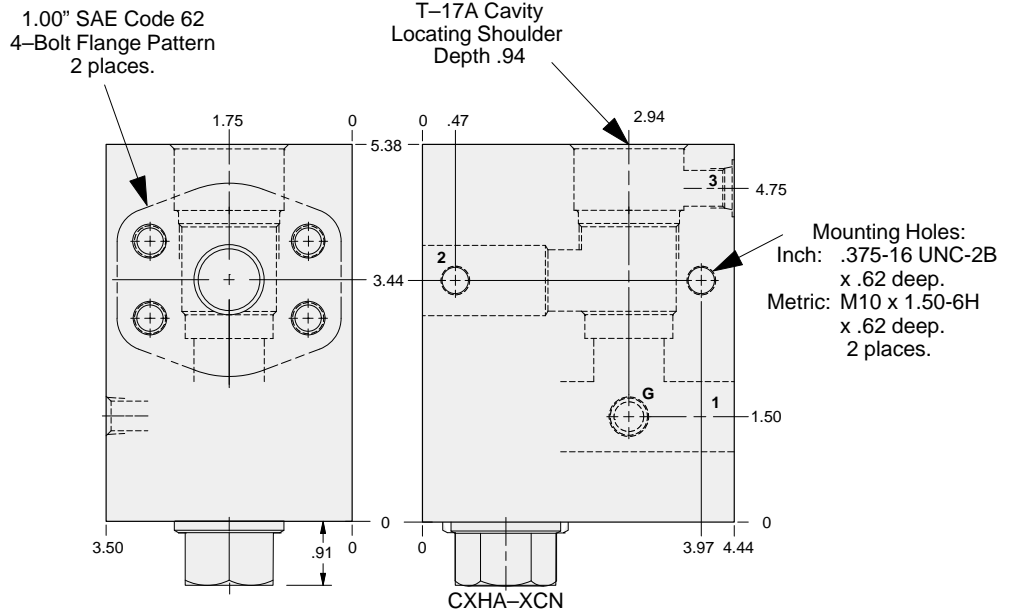

S3
T17A

Mounting Hole Dimensions	Port 3	Gage Port	ALUMINUM		DUCTILE IRON	
			Part Number	List Price	Part Number	List Price
Inch	SAE-6	.25 NPTF	H64		H64/S	
Metric	.25 BSPP	.25 BSPP	H64/M		H64/T	

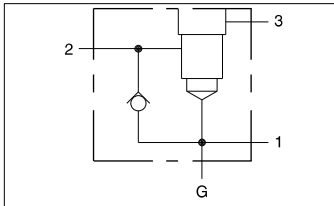

TYPICAL CARTRIDGES USED WITH THIS BODY

- RSHC - *** Page 2.07
 SQHB - *** Page 2.09
 RSHE - *** Page 2.11

Cartridge seal type determines check valve seal type.

Instructions for ordering complete cartridge and body assemblies. Page v

Pressure ratings, material specifications. Page 11.02

1.25" SAE Code 62 flange port body with reverse free flow check and gage port for sequence applications.

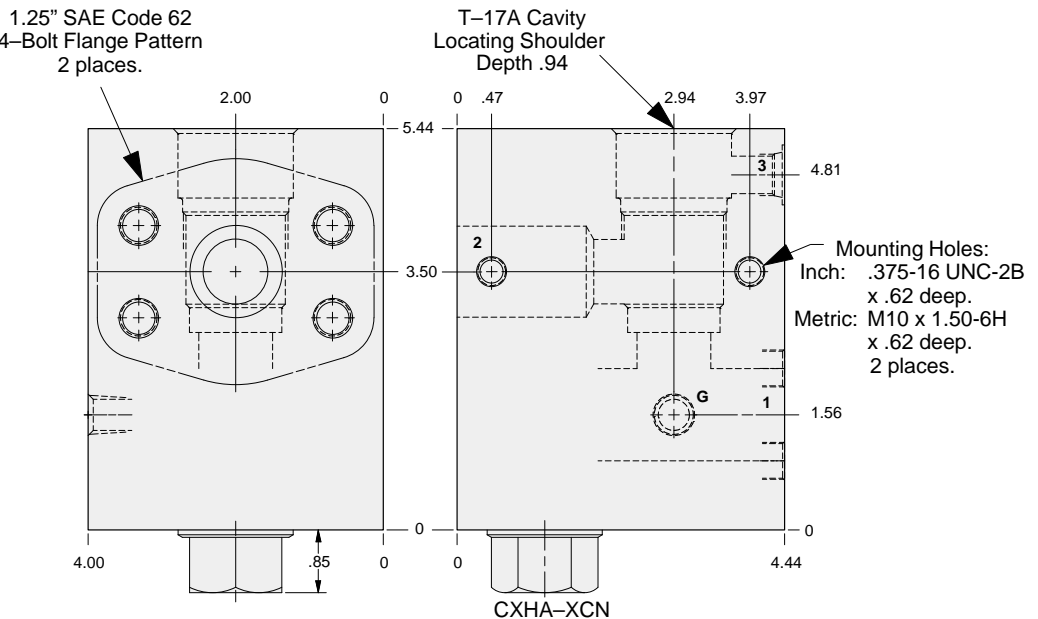

Mounting Hole Dimensions	Port 3	Gage Port	ALUMINUM		DUCTILE IRON	
			Part Number	List Price	Part Number	List Price
Inch	SAE-6	.25 NPTF	H65		H65/S	
Metric	.25 BSPP	.25 BSPP	H65/M		H65/T	



LINE MOUNT BODIES



- Aluminum rated to 3000 psi.
- Ductile Iron rated to 5000 psi.

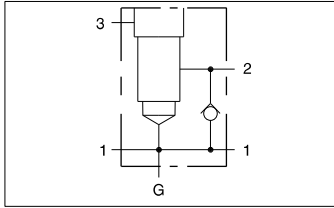

TYPICAL CARTRIDGES USED WITH THIS BODY

- S3** RSHC - *** Page 2.07
T17A SQHB - *** Page 2.09
 RSHE - *** Page 2.11

Cartridge seal type determines check valve seal type.

Instructions for ordering complete cartridge and body assemblies. Page v

Pressure ratings, material specifications. Page 11.02

Body with reverse free flow check and gage port for sequence applications.

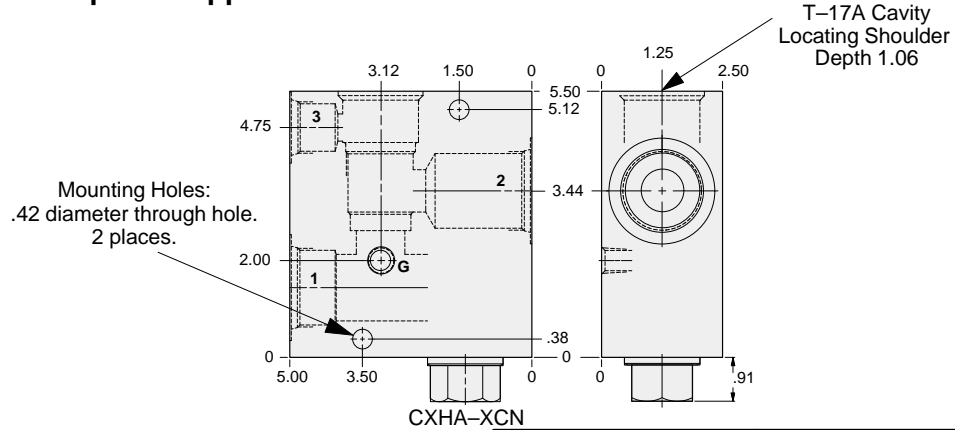

Ports 1 & 2	Port 3	Gage Port	ALUMINUM		DUCTILE IRON	
			Part Number	List Price	Part Number	List Price
.75 NPTF	.25 NPTF	.25 NPTF	H6D		H6D/S	
1.00 NPTF	.25 NPTF	.25 NPTF	H6E		H6E/S	
1.25 NPTF	.25 NPTF	.25 NPTF	H6F		H6F/S	
SAE-12	SAE-6	.25 NPTF	H6L		H6L/S	
SAE-16	SAE-6	.25 NPTF	H6M		H6M/S	
SAE-20	SAE-6	.25 NPTF	H6N		H6N/S	
.75 BSPP	.25 BSPP	.25 BSPP	H6W		H6W/S	
1.00 BSPP	.25 BSPP	.25 BSPP	H6X		H6X/S	
1.25 BSPP	.25 BSPP	.25 BSPP	H6Y		H6Y/S	

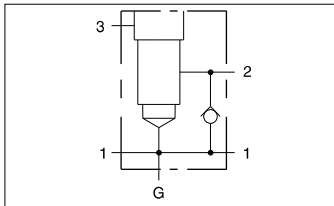

TYPICAL CARTRIDGES USED WITH THIS BODY

- RSHC - *** Page 2.07
 SQHB - *** Page 2.09
 RSHE - *** Page 2.11

Cartridge seal type determines check valve seal type.

Instructions for ordering complete cartridge and body assemblies. Page v

Pressure ratings, material specifications. Page 11.02

Through port body with reverse free flow check and gage port for sequence applications.

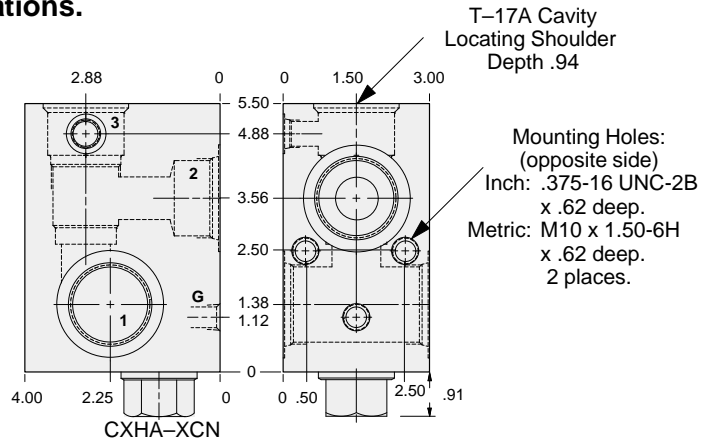

Ports 1 & 2	Port 3	Gage Port	ALUMINUM		DUCTILE IRON	
			Part Number	List Price	Part Number	List Price
.75 NPTF	.25 NPTF	.25 NPTF	H7D		H7D/S	
1.00 NPTF	.25 NPTF	.25 NPTF	H7E		H7E/S	
1.25 NPTF	.25 NPTF	.25 NPTF	H7F		H7F/S	
SAE-12	SAE-6	.25 NPTF	H7L		H7L/S	
SAE-16	SAE-6	.25 NPTF	H7M		H7M/S	
SAE-20	SAE-6	.25 NPTF	H7N		H7N/S	
.75 BSPP	.25 BSPP	.25 BSPP	H7W		H7W/S	
1.00 BSPP	.25 BSPP	.25 BSPP	H7X		H7X/S	
1.25 BSPP	.25 BSPP	.25 BSPP	H7Y		H7Y/S	



LINE MOUNT BODIES



- Aluminum rated to 3000 psi.
- Ductile Iron rated to 5000 psi.

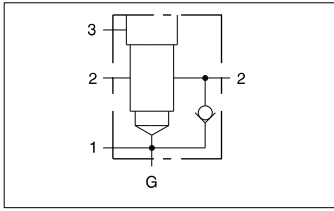

TYPICAL CARTRIDGES USED WITH THIS BODY

PBHB - *** Page 3.07
PBHC - *** Page 3.09

Cartridge seal type determines check valve seal type.

Instructions for ordering complete cartridge and body assemblies. Page v

Pressure ratings, material specifications. Page 11.02

Through port body with reverse free-flow check and gage port for reducing applications.

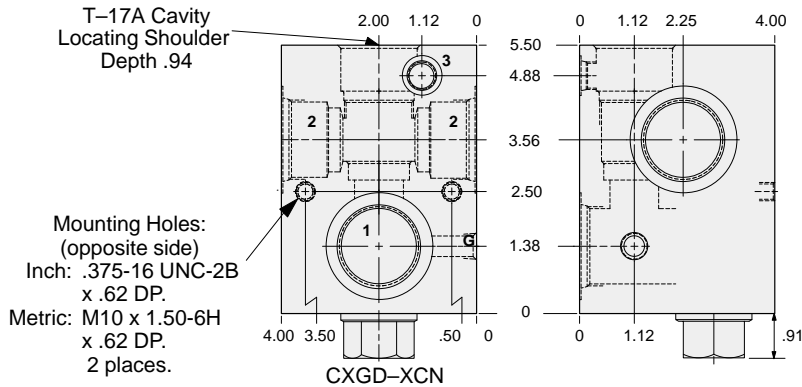

Ports 1 & 2	Port 3	Gage Port	ALUMINUM		DUCTILE IRON	
			Part Number	List Price	Part Number	List Price
.75 NPTF	.25 NPTF	.25 NPTF	H3D		H3D/S	
1.00 NPTF	.25 NPTF	.25 NPTF	H3E		H3E/S	
1.25 NPTF	.25 NPTF	.25 NPTF	H3F		H3F/S	
SAE-12	SAE-6	.25 NPTF	H3L		H3L/S	
SAE-16	SAE-6	.25 NPTF	H3M		H3M/S	
SAE-20	SAE-6	.25 NPTF	H3N		H3N/S	
.75 BSPP	.25 BSPP	.25 BSPP	H3W		H3W/S	
1.00 BSPP	.25 BSPP	.25 BSPP	H3X		H3X/S	
1.25 BSPP	.25 BSPP	.25 BSPP	H3Y		H3Y/S	

S3
T17A

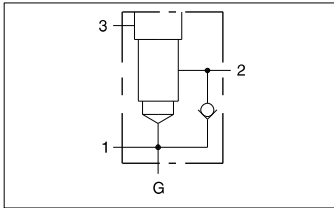

TYPICAL CARTRIDGES USED WITH THIS BODY

PPHB - *** Page 3.11
PPHC - *** Page 3.13

Cartridge seal type determines check valve seal type.

Instructions for ordering complete cartridge and body assemblies. Page v

Pressure ratings, material specifications. Page 11.02

Body with high capacity port 3 reverse free-flow check and gage port for reducing/relieving applications.

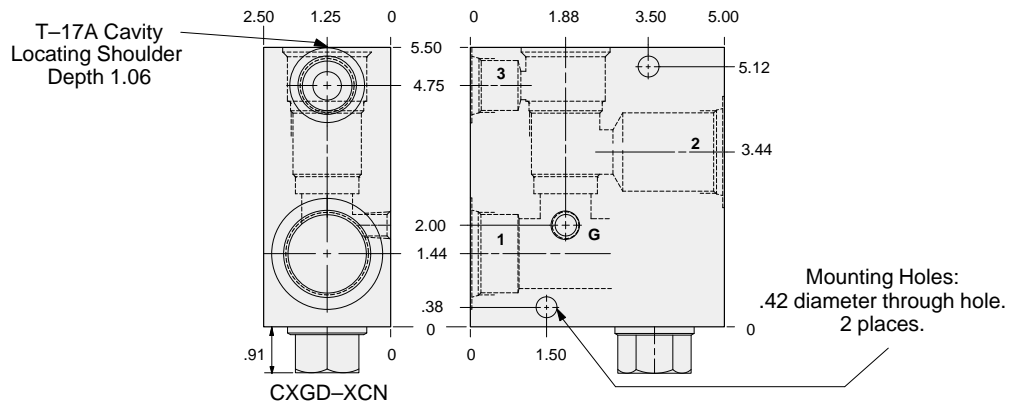

Ports 1 & 2	Port 3	Gage Port	ALUMINUM		DUCTILE IRON	
			Part Number	List Price	Part Number	List Price
.75 NPTF	.75 NPTF	.25 NPTF	H4D		H4D/S	
1.00 NPTF	.75 NPTF	.25 NPTF	H4E		H4E/S	
1.25 NPTF	.75 NPTF	.25 NPTF	H4F		H4F/S	
SAE-12	SAE-12	.25 NPTF	H4L		H4L/S	
SAE-16	SAE-12	.25 NPTF	H4M		H4M/S	
SAE-20	SAE-12	.25 NPTF	H4N		H4N/S	
.75 BSPP	.75 BSPP	.25 BSPP	H4W		H4W/S	
1.00 BSPP	.75 BSPP	.25 BSPP	H4X		H4X/S	
1.25 BSPP	.75 BSPP	.25 BSPP	H4Y		H4Y/S	



LINE MOUNT BODIES



- Aluminum rated to 3000 psi.
- Ductile Iron rated to 5000 psi.

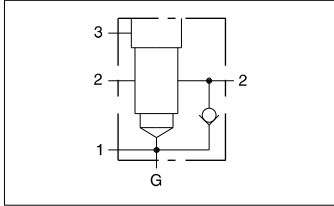

Through port 1.00" SAE Code 61 flange port body with reverse free flow check and gage port for reducing applications.

TYPICAL CARTRIDGES USED WITH THIS BODY

PBHB - *** Page 3.07
PBHC - *** Page 3.09

Cartridge seal type determines check valve seal type.

Instructions for ordering complete cartridge and body assemblies. Page v

Pressure ratings, material specifications. Page 11.02

SAE Specifications Page 11.03

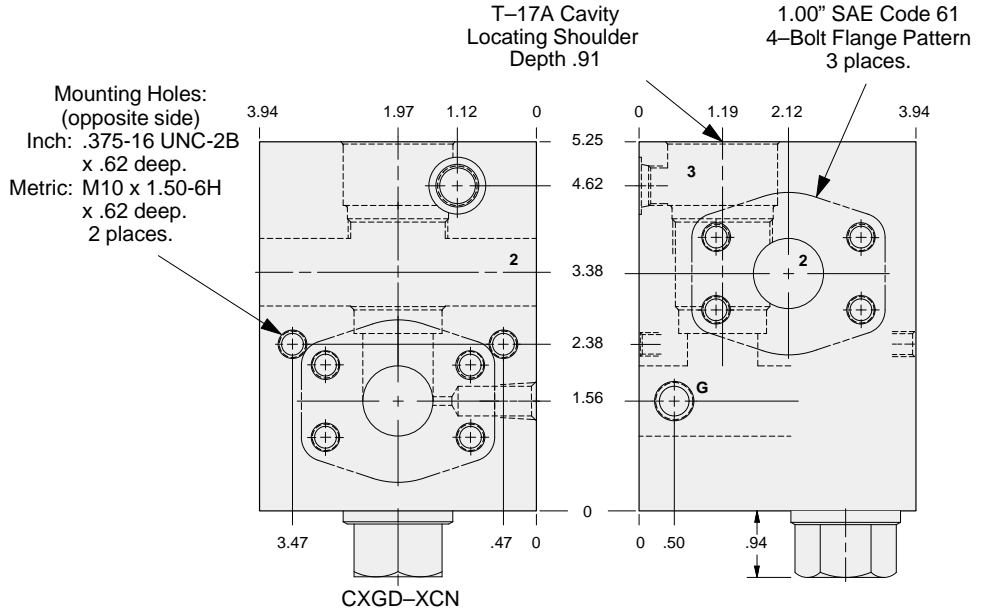

S3
T17A

Mounting Hole Dimensions	Port 3	Gage Port	ALUMINUM		DUCTILE IRON	
			Part Number	List Price	Part Number	List Price
Inch	SAE-6	.25 NPTF	H3P		H3P/S	
Metric	.25 BSPP	.25 BSPP	H3P/M		H3P/T	



LINE MOUNT BODIES



- Aluminum rated to 3000 psi.
- Ductile Iron rated to 5000 psi.

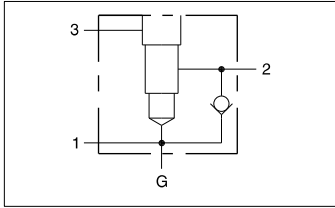

1.25" SAE Code 61 flange port body with reverse free flow check and gage port for reducing applications.

1.25" SAE Code 61
4-Bolt Flange Pattern
2 places.

T-17A Cavity
Locating Shoulder
Depth 1.44

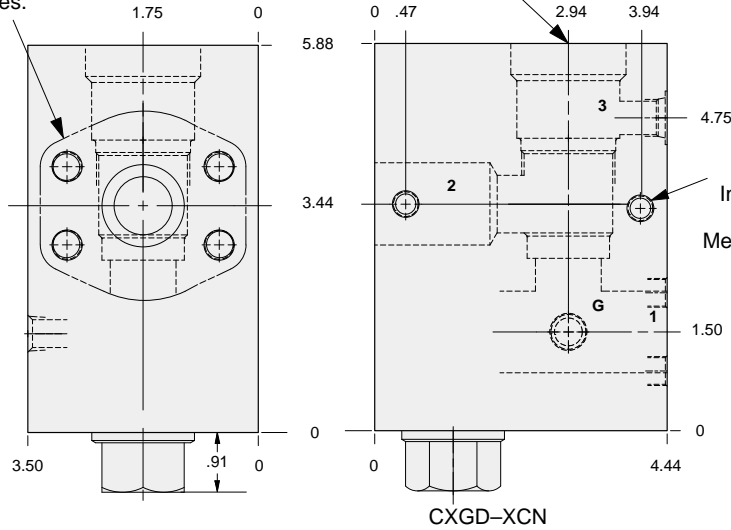

Mounting Holes:
Inch: .375-16 UNC-2B
x .62 deep.
Metric: M10 x 1.50-6H
x .62 deep.
2 places.

TYPICAL CARTRIDGES USED WITH THIS BODY

S3 PBHB - *** Page 3.07
T17A PBHC - *** Page 3.09

Cartridge seal type determines check valve seal type.

Instructions for ordering complete cartridge and body assemblies. Page v

Pressure ratings, material specifications. Page 11.02

SAE Specifications Page 11.03

Mounting Hole Dimensions	Port 3	Gage Port	ALUMINUM		DUCTILE IRON	
			Part Number	List Price	Part Number	List Price
Inch	SAE-6	.25 NPTF	H2Q		H2Q/S	
Metric	.25 BSPP	.25 BSPP	H2Q/M		H2Q/T	

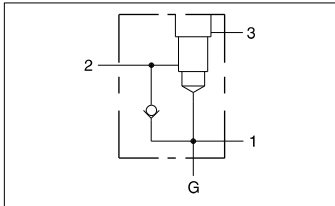

1.25" SAE Code 62 flange port body with reverse free flow check and gage port for reducing applications.

1.25" SAE Code 62
4-Bolt Flange Pattern
2 places.

T-17A Cavity
Locating Shoulder
Depth .94

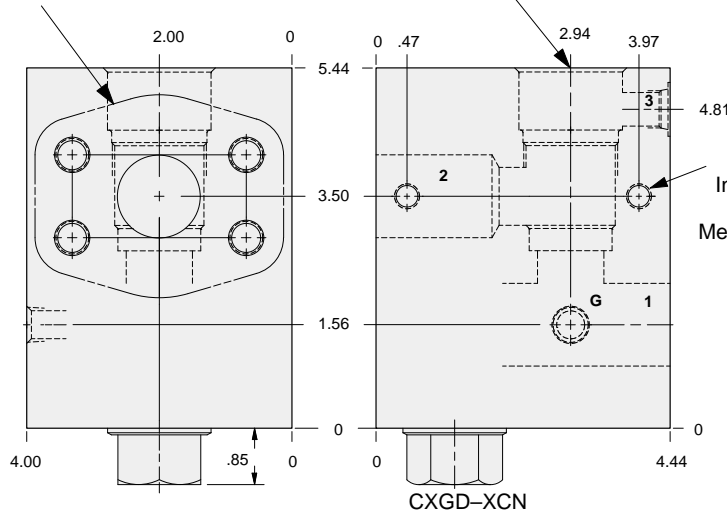

Mounting Holes:
Inch: .375-16 UNC-2B
x .62 deep.
Metric: M10 x 1.50-6H
x .62 deep.
2 places.

TYPICAL CARTRIDGES USED WITH THIS BODY

PBHB - *** Page 3.07
PBHC - *** Page 3.09

Cartridge seal type determines check valve seal type.

Instructions for ordering complete cartridge and body assemblies. Page v

Pressure ratings, material specifications. Page 11.02

SAE Specifications Page 11.03

Mounting Hole Dimensions	Port 3	Gage Port	ALUMINUM		DUCTILE IRON	
			Part Number	List Price	Part Number	List Price
Inch	SAE-6	.25 NPTF	H25		H25/S	
Metric	.25 BSPP	.25 BSPP	H25/M		H25/T	



LINE MOUNT BODIES



- Aluminum rated to 3000 psi.
- Ductile Iron rated to 5000 psi.

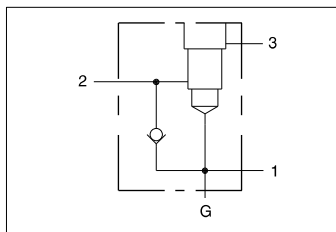

1.25" SAE Code 61 flange port body with high capacity port 3 reverse free flow check and gage port for reducing/relieving applications.

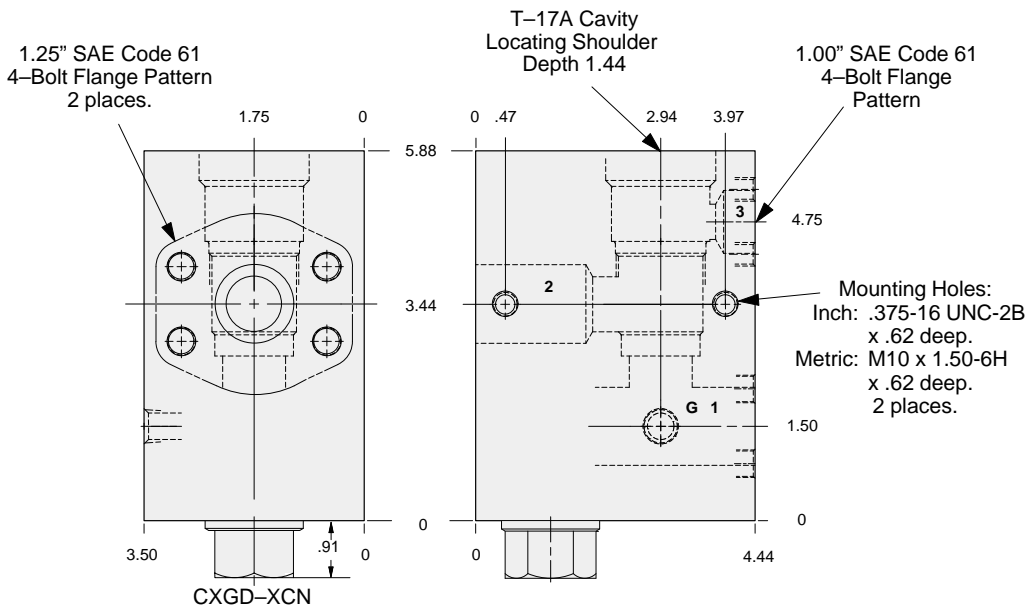

S3
T17A

TYPICAL CARTRIDGES USED WITH THIS BODY

PPHB - *** Page 3.11
PPHC - *** Page 3.13

Cartridge seal type determines check valve seal type.

Instructions for ordering complete cartridge and body assemblies. Page v

Pressure ratings, material specifications. Page 11.02

SAE Specifications Page 11.03

Mounting Hole Dimensions	Port 3 SAE Code 61	Gage Port	ALUMINUM		DUCTILE IRON	
			Part Number	List Price	Part Number	List Price
Inch	1.00"	.25 NPTF	H4Q		H4Q/S	
Metric	1.00"	.25 BSPP	H4Q/M		H4Q/T	

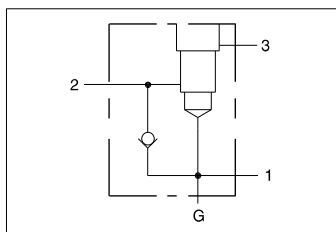

1.25" SAE Code 62 flange port body with high capacity port 3 reverse free flow check and gage port for reducing/relieving applications.

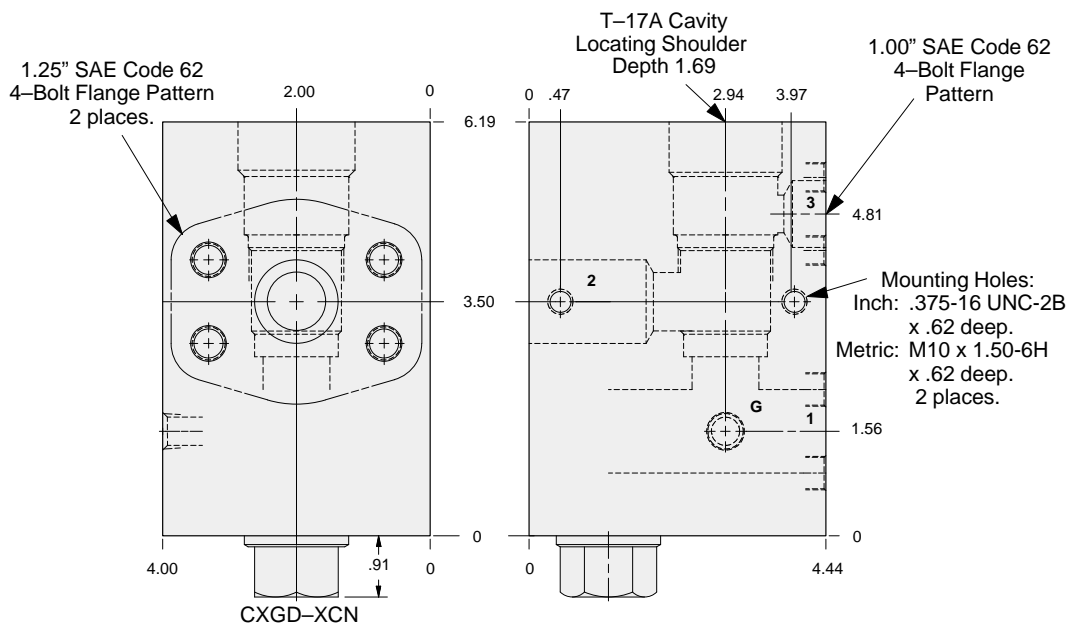

TYPICAL CARTRIDGES USED WITH THIS BODY

PPHB - *** Page 3.11
PPHC - *** Page 3.13

Cartridge seal type determines check valve seal type.

Instructions for ordering complete cartridge and body assemblies. Page v

Pressure ratings, material specifications. Page 11.02

SAE Specifications Page 11.03

Mounting Hole Dimensions	Port 3 SAE Code 62	Gage Port	ALUMINUM		DUCTILE IRON	
			Part Number	List Price	Part Number	List Price
Inch	1.00"	.25 NPTF	H45		H45/S	
Metric	1.00"	.25 BSPP	H45/M		H45/T	



LINE MOUNT BODIES



- Aluminum rated to 3000 psi.
- Ductile Iron rated to 5000 psi.

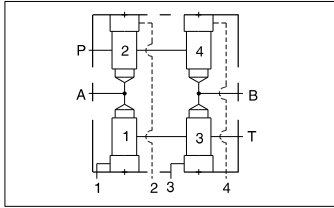

Four cavity four-way logic body for directional applications.

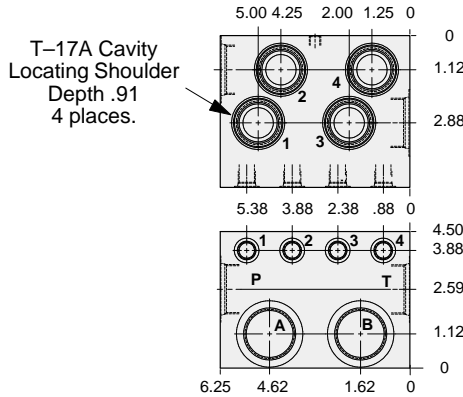

Mounting Holes:
 Inch: .375-16 UNC-2B
 x .62 deep.
 Metric: M10 x 1.50-6H
 x .62 deep.
 2 places.

TYPICAL CARTRIDGES USED WITH THIS BODY

S3 T17A	LOHC - ***	Page 9.09
	LKHC - ***	Page 9.11
	LPHC - ***	Page 9.13
	LRHC - ***	Page 9.15

Instructions for ordering complete cartridge and body assemblies. Page v

Pressure ratings, material specifications. Page 11.02

Mounting Hole Dimensions	Ports A & B P & T	Ports 1 & 2, 3 & 4	ALUMINUM		DUCTILE IRON	
			Part Number	List Price	Part Number	List Price
Inch	.75 NPTF	.25 NPTF	YRS		YRS/S	
Inch	1.00 NPTF	.25 NPTF	YRB		YRB/S	
Inch	1.25 NPTF	.25 NPTF	YRO		YRO/S	
Inch	SAE-12	SAE-6	YRN		YRN/S	
Inch	SAE-16	SAE-6	YRR		YRR/S	
Inch	SAE-20	SAE-6	YRL		YRL/S	
Metric	.75 BSPP	.25 BSPP	YRK		YRK/S	
Metric	1.00 BSPP	.25 BSPP	YRJ		YRJ/S	
Metric	1.25 BSPP	.25 BSPP	YRG		YRG/S	

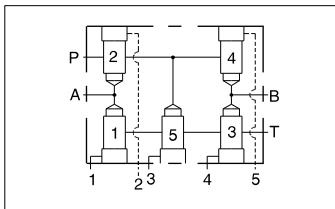

Five cavity four-way logic body for directional applications.

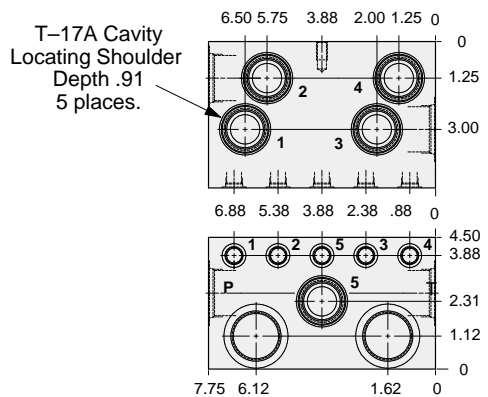

Mounting Holes:
 Inch: .375-16 UNC-2B
 x .62 deep.
 Metric: M10 x 1.50-6H
 x .62 deep.
 2 places.

TYPICAL CARTRIDGES USED WITH THIS BODY

S3 T17A	LOHC - ***	Page 9.09
	LKHC - ***	Page 9.11
	LPHC - ***	Page 9.13
	LRHC - ***	Page 9.15

Instructions for ordering complete cartridge and body assemblies. Page v

Pressure ratings, material specifications. Page 11.02

Mounting Hole Dimensions	Ports A & B P & T	Ports 1, 2, 3, 4, & 5	ALUMINUM		DUCTILE IRON	
			Part Number	List Price	Part Number	List Price
Inch	.75 NPTF	.25 NPTF	YQS		YQS/S	
Inch	1.00 NPTF	.25 NPTF	YQB		YQB/S	
Inch	1.25 NPTF	.25 NPTF	YQO		YQO/S	
Inch	SAE-12	SAE-6	YQN		YQN/S	
Inch	SAE-16	SAE-6	YQR		YQR/S	
Inch	SAE-20	SAE-6	YQL		YQL/S	
Metric	.75 BSPP	.25 BSPP	YQK		YQK/S	
Metric	1.00 BSPP	.25 BSPP	YQJ		YQJ/S	
Metric	1.25 BSPP	.25 BSPP	YQG		YQG/S	



LINE MOUNT BODIES



- Aluminum rated to 3000 psi.
- Ductile Iron rated to 5000 psi.

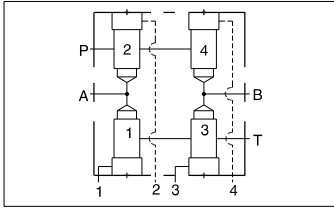

Four cavity four-way 1.00" SAE Code 61 flange port logic body for directional applications.

TYPICAL CARTRIDGES USED WITH THIS BODY

- LOHC - *** Page 9.09
- LKHC - *** Page 9.11
- LPHC - *** Page 9.13
- LRHC - *** Page 9.15

Instructions for ordering complete cartridge and body assemblies. Page v

Pressure ratings, material specifications. Page 11.02

SAE Specifications Page 11.03

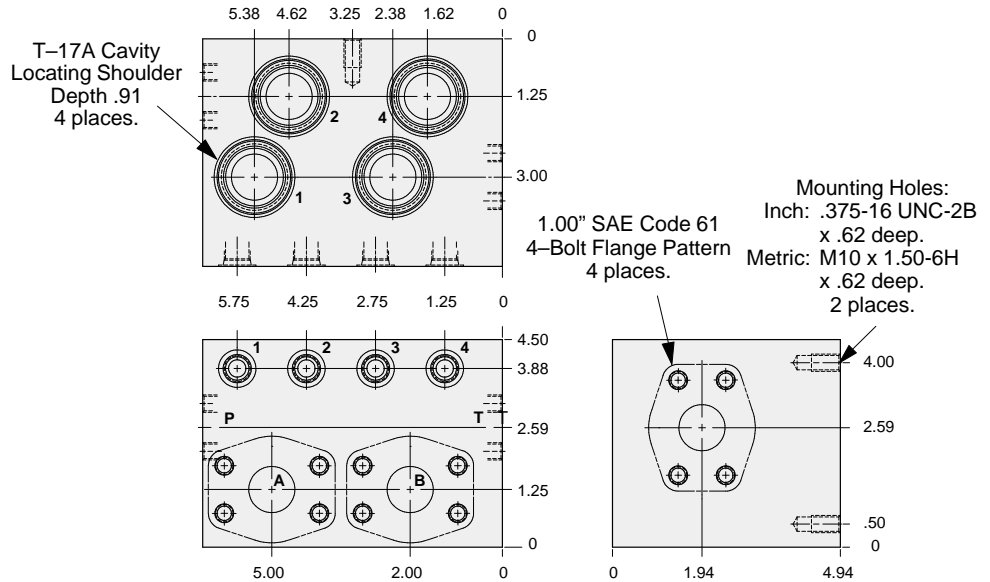

Mounting Hole Dimensions	Ports 1 & 2, 3 & 4	ALUMINUM		DUCTILE IRON	
		Part Number	List Price	Part Number	List Price
Inch	SAE-6	YRH		YRH/S	
Metric	.25 BSPP	YRH/M		YRH/T	

S3
T17A

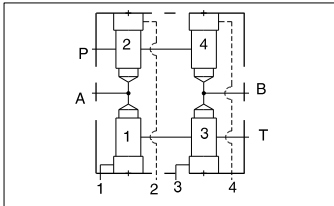

Four cavity four-way 1.25" SAE Code 61 flange port logic body for directional applications.

TYPICAL CARTRIDGES USED WITH THIS BODY

- LOHC - *** Page 9.09
- LKHC - *** Page 9.11
- LPHC - *** Page 9.13
- LRHC - *** Page 9.15

Instructions for ordering complete cartridge and body assemblies. Page v

Pressure ratings, material specifications. Page 11.02

SAE Specifications Page 11.03

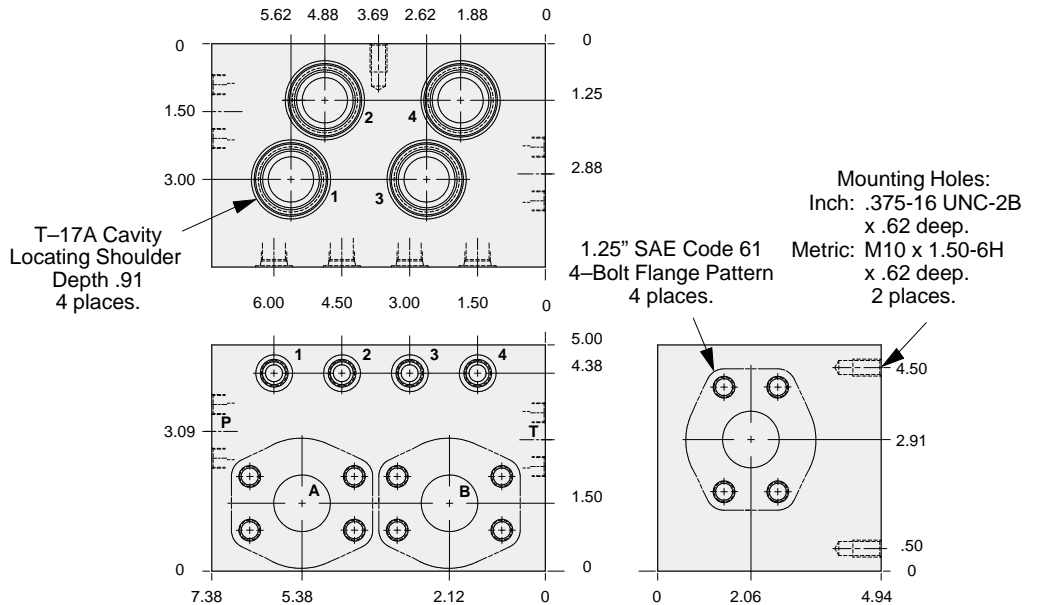

Mounting Hole Dimensions	Ports 1 & 2, 3 & 4	ALUMINUM		DUCTILE IRON	
		Part Number	List Price	Part Number	List Price
Inch	SAE-6	YRF		YRF/S	
Metric	.25 BSPP	YRF/M		YRF/T	



LINE MOUNT BODIES



- Aluminum rated to 3000 psi.
- Ductile Iron rated to 5000 psi.

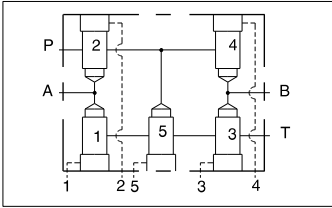

Five cavity four-way 1.00" SAE Code 61 flange port logic body for directional applications.

T-17A Cavity Locating Shoulder Depth .91 5 places.

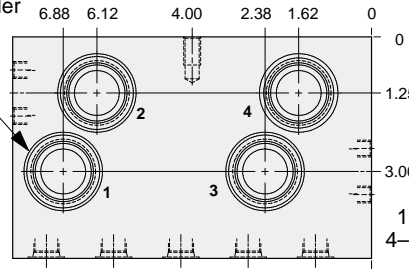

1.00" SAE Code 61 4-Bolt Flange Pattern 4 places.

Mounting Holes:
Inch: .375-16 UNC-2B x .62 deep.
Metric: M10 x 1.50-6H x .62 deep. 2 places.

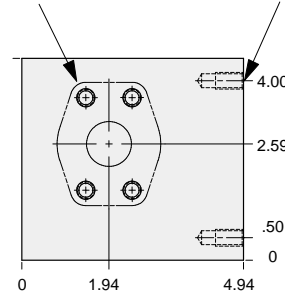
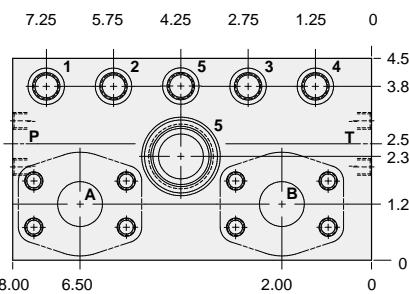

TYPICAL CARTRIDGES USED WITH THIS BODY

S3	LOHC - ***	Page 9.09
T17A	LKHC - ***	Page 9.11
	LPHC - ***	Page 9.13
	LRHC - ***	Page 9.15

Instructions for ordering complete cartridge and body assemblies. Page v

Pressure ratings, material specifications. Page 11.02

SAE Specifications Page 11.03

Mounting Hole Dimensions	Ports 1, 2, 3, 4, & 5	ALUMINUM		DUCTILE IRON	
		Part Number	List Price	Part Number	List Price
Inch	SAE-6	YQH		YQH/S	
Metric	.25 BSPP	YQH/M		YQH/T	

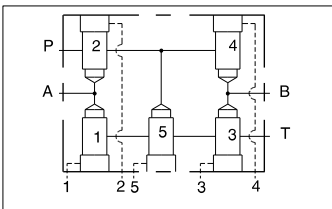

Five cavity four-way 1.25" SAE Code 61 flange port logic body for directional applications.

T-17A Cavity Locating Shoulder Depth .91 5 places.

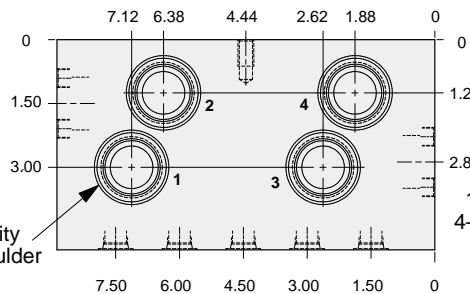

1.25" SAE Code 61 4-Bolt Flange Pattern 4 places.

Mounting Holes:
Inch: .375-16 UNC-2B x .62 deep.
Metric: M10 x 1.50-6H x .62 deep. 2 places.

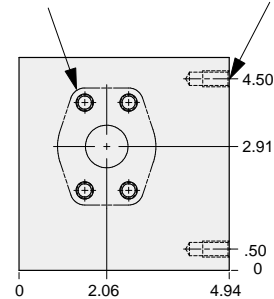
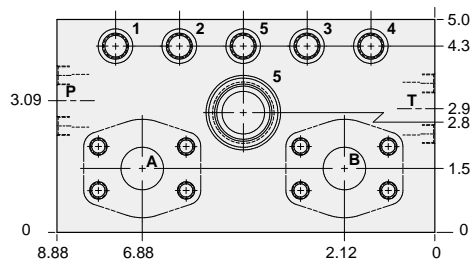

TYPICAL CARTRIDGES USED WITH THIS BODY

	LOHC - ***	Page 9.09
	LKHC - ***	Page 9.11
	LPHC - ***	Page 9.13
	LRHC - ***	Page 9.15

Instructions for ordering complete cartridge and body assemblies. Page v

Pressure ratings, material specifications. Page 11.02

SAE Specifications Page 11.03

Mounting Hole Dimensions	Ports 1, 2, 3, 4, & 5	ALUMINUM		DUCTILE IRON	
		Part Number	List Price	Part Number	List Price
Inch	SAE-6	YQF		YQF/S	
Metric	.25 BSPP	YQF/M		YQF/T	



LINE MOUNT BODIES



- Aluminum rated to 3000 psi.
- Ductile Iron rated to 5000 psi.

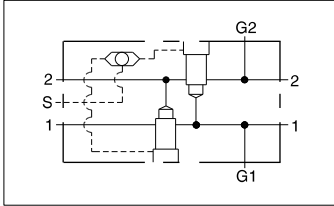

TYPICAL CARTRIDGES USED WITH THIS BODY

RVGA - *** Page 1.19

Cartridge seal type determines shuttle valve seal type.

Instructions for ordering complete cartridge and body assemblies. Page v

Pressure ratings, material specifications. Page 11.02

Two cavity through port body with shuttle and gage ports.

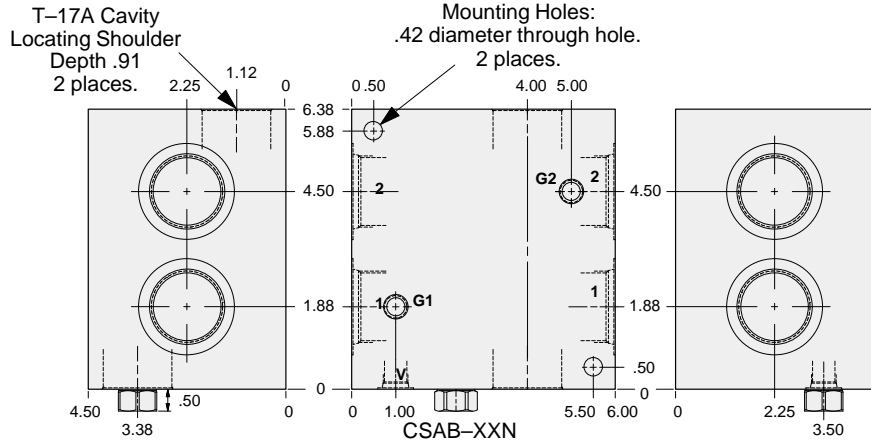

S3
T17A

Ports 1 & 2	Port V	Gage Ports	ALUMINUM		DUCTILE IRON	
			Part Number	List Price	Part Number	List Price
.75 NPTF	.25 NPTF	.25 NPTF	XCD		XCD/S	
1.00 NPTF	.25 NPTF	.25 NPTF	XCE		XCE/S	
1.25 NPTF	.25 NPTF	.25 NPTF	XCF		XCF/S	
SAE-12	SAE-6	.25 NPTF	XCL		XCL/S	
SAE-16	SAE-6	.25 NPTF	XCM		XCM/S	
SAE-20	SAE-6	.25 NPTF	XCN		XCN/S	
.75 BSPP	.25 BSPP	.25 BSPP	XCW		XCW/S	
1.00 BSPP	.25 BSPP	.25 BSPP	XCX		XCX/S	
1.25 BSPP	.25 BSPP	.25 BSPP	XCY		XCYS	



LINE MOUNT BODIES



- Aluminum rated to 3000 psi.
- Ductile Iron rated to 5000 psi.

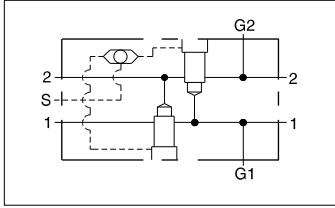

Two cavity through flange port 1.00" SAE Code 61 body with shuttle and gage ports.

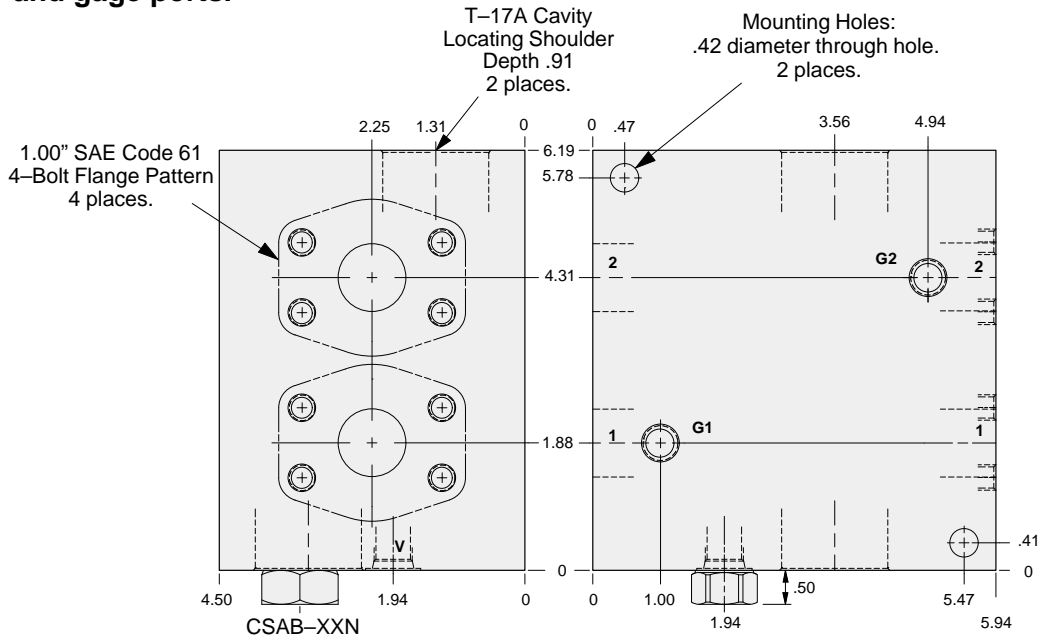

TYPICAL CARTRIDGES USED WITH THIS BODY

S3 T17A RVGA - *** Page 1.19
Cartridge seal type determines shuttle valve seal type.

Instructions for ordering complete cartridge and body assemblies. Page v

Pressure ratings, material specifications. Page 11.02

SAE Specifications Page 11.03

Mounting Hole Dimensions	Port V	Gage Ports	ALUMINUM		DUCTILE IRON	
			Part Number	List Price	Part Number	List Price
Inch	SAE-6	.25 NPTF	XCP		XCP/S	
Metric	.25 BSPP	.25 BSPP	XCP/M		XCP/T	

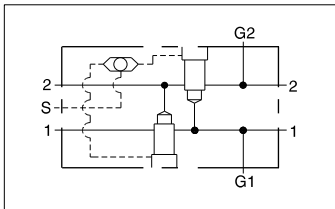

Two cavity through flange port 1.00" SAE Code 62 body with shuttle and gage ports.

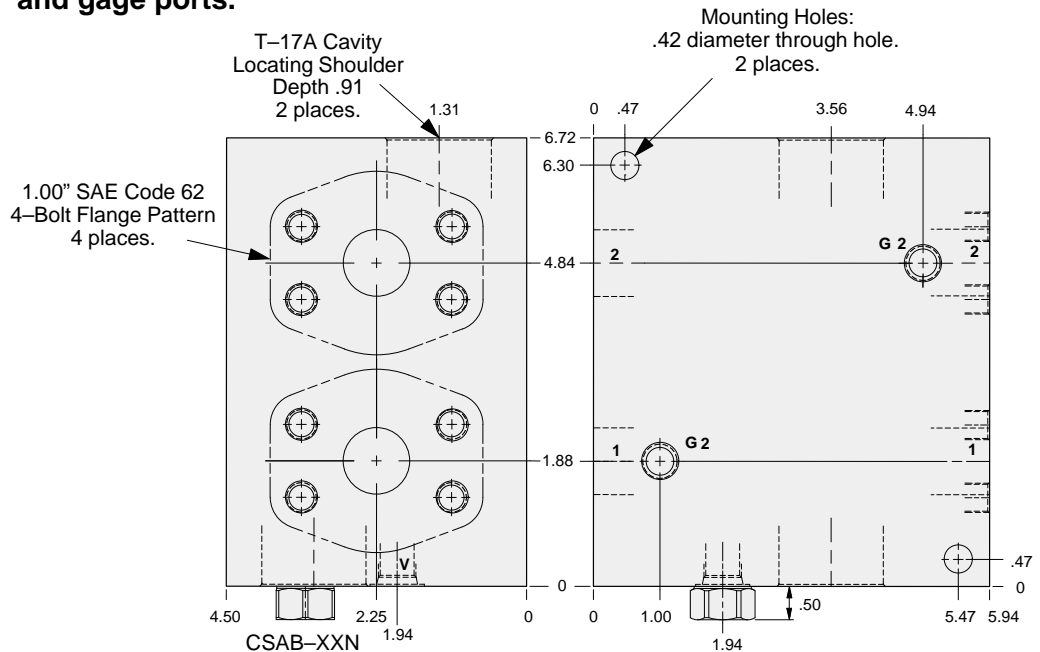

TYPICAL CARTRIDGES USED WITH THIS BODY

RVGA - *** Page 1.19

Cartridge seal type determines shuttle valve seal type.

Instructions for ordering complete cartridge and body assemblies. Page v

Pressure ratings, material specifications. Page 11.02

SAE Specifications Page 11.03

Mounting Hole Dimensions	Port V	Gage Ports	ALUMINUM		DUCTILE IRON	
			Part Number	List Price	Part Number	List Price
Inch	SAE-6	.25 NPTF	XC4		XC4/S	
Metric	.25 BSPP	.25 BSPP	XC4/M		XC4/T	



LINE MOUNT BODIES



- Aluminum rated to 3000 psi.
- Ductile Iron rated to 5000 psi.

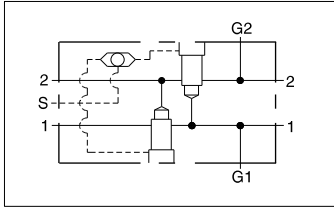

Two cavity through flange port 1.25" SAE Code 61 body with shuttle and gage ports.

1.25" SAE Code 61
4-Bolt Flange Pattern
4 places.

T-17A Cavity
Locating Shoulder
Depth .91
2 places.

Mounting Holes:
.42 diameter through hole.
2 places.

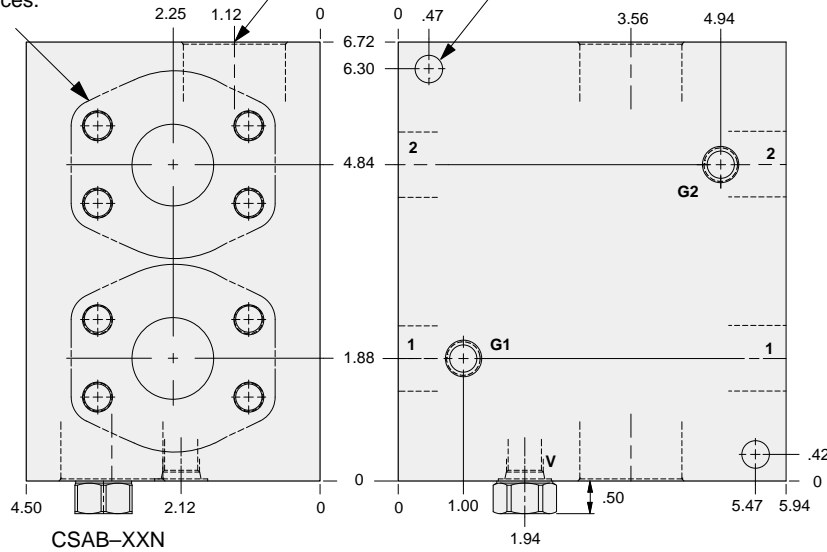

CSAB-XXN

TYPICAL CARTRIDGES USED WITH THIS BODY

RVGA - *** Page 1.19

Cartridge seal type determines shuttle valve seal type.

Instructions for ordering complete cartridge and body assemblies. Page v

Pressure ratings, material specifications. Page 11.02

SAE Specifications Page 11.03

Mounting Hole Dimensions	Port V	Gage Ports	ALUMINUM		DUCTILE IRON	
			Part Number	List Price	Part Number	List Price
Inch	SAE-6	.25 NPTF	XCQ		XCQ/S	
Metric	.25 BSPP	.25 BSPP	XCQ/M		XCQ/T	

S3
T17A

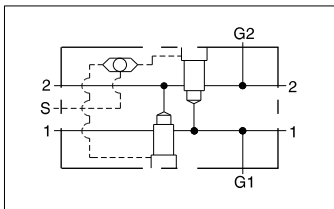

Two cavity through flange port 1.25" SAE Code 62 body with shuttle and gage ports.

1.25" SAE Code 62
4-Bolt Flange Pattern
4 places.

T-17A Cavity
Locating Shoulder
Depth .91
2 places.

Mounting Holes:
.42 diameter through hole.
2 places.

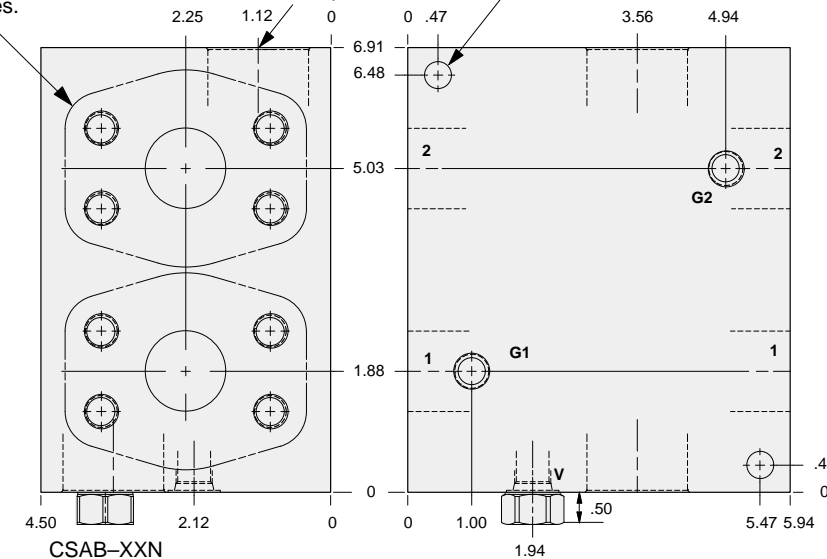

CSAB-XXN

TYPICAL CARTRIDGES USED WITH THIS BODY

RVGA - *** Page 1.19

Cartridge seal type determines shuttle valve seal type.

Instructions for ordering complete cartridge and body assemblies. Page v

Pressure ratings, material specifications. Page 11.02

SAE Specifications Page 11.03

Mounting Hole Dimensions	Port V	Gage Ports	ALUMINUM		DUCTILE IRON	
			Part Number	List Price	Part Number	List Price
Inch	SAE-6	.25 NPTF	XC5		XC5/S	
Metric	.25 BSPP	.25 BSPP	XC5/M		XC5/T	



LINE MOUNT BODIES



- Aluminum rated to 3000 psi.
- Ductile Iron rated to 5000 psi.

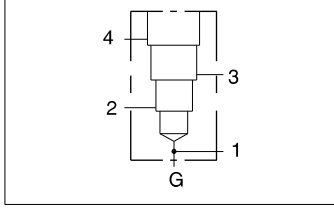

90 degree body with gage port.

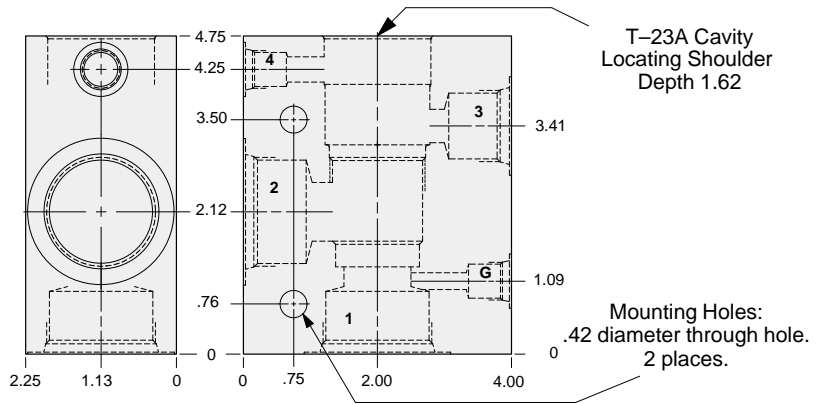

TYPICAL CARTRIDGES USED WITH THIS BODY

RVGD - ***	Page 1.21
PVHA - ***	Page 3.15
PVHB - ***	Page 3.17
CWGA - ***	Page 4.19
CWGG - ***	Page 4.21
CVGV - ***	Page 4.23
FVEA - ***	Page 6.05

S3
T23A

Instructions for ordering complete cartridge and body assemblies. Page v

Pressure ratings, material specifications. Page 11.02

Ports 1 & 2	Port 3	Port 4	Gage Port	ALUMINUM		DUCTILE IRON	
				Part Number	List Price	Part Number	List Price
.75 NPTF	.75 NPTF	.25 NPTF	.25 NPTF	PAD		PAD/S	
1.00 NPTF	.75 NPTF	.25 NPTF	.25 NPTF	PAE		PAE/S	
1.25 NPTF	.75 NPTF	.25 NPTF	.25 NPTF	PAF		PAF/S	
SAE-12	SAE-12	SAE-6	.25 NPTF	PAL		PAL/S	
SAE-16	SAE-12	SAE-6	.25 NPTF	PAM		PAM/S	
SAE-20	SAE-12	SAE-6	.25 NPTF	PAN		PAN/S	
.75 BSPP	.75 BSPP	.25 BSPP	.25 BSPP	PAW		PAW/S	
1.00 BSPP	.75 BSPP	.25 BSPP	.25 BSPP	PAX		PAX/S	
1.25 BSPP	.75 BSPP	.25 BSPP	.25 BSPP	PAY		PAY/S	



LINE MOUNT BODIES



- Aluminum rated to 3000 psi.
- Ductile Iron rated to 5000 psi.

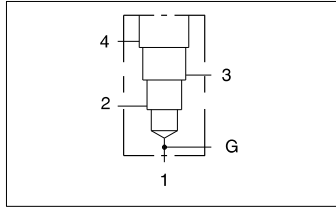

90 degree 1.00" SAE Code 61 flange port body with gage port.

1.00" SAE Code 61
4-Bolt Flange Pattern
3 places.

Mounting Holes:
(opposite side)
Inch: .375-16 UNC-2B x .75 deep.
Metric: M10 x 1.50-6H x .75 deep.
2 places.

T-23A Cavity
Locating Shoulder
Depth 1.63

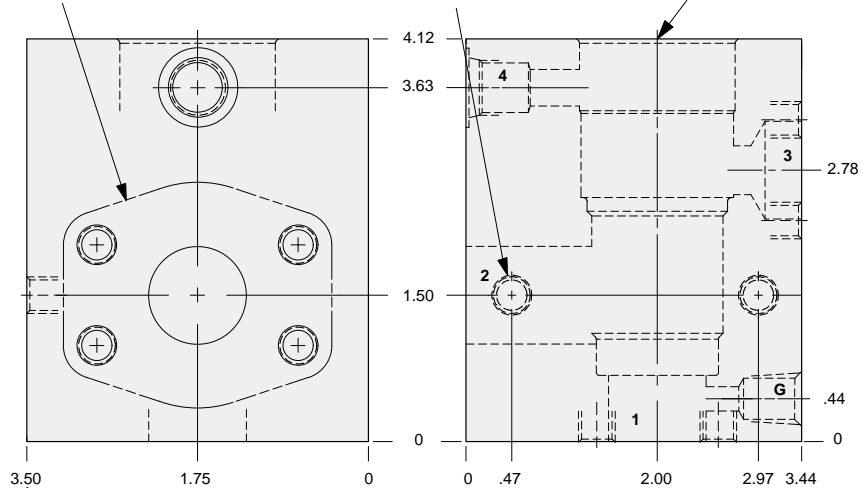

TYPICAL CARTRIDGES USED WITH THIS BODY

RVGD - ***	Page 1.21
PVHA - ***	Page 3.15
PVHB - ***	Page 3.17
CWGA - ***	Page 4.19
CWGG - ***	Page 4.21
CVGV - ***	Page 4.23
FVEA - ***	Page 6.05

Instructions for ordering complete cartridge and body assemblies. Page v

Pressure ratings, material specifications. Page 11.02

SAE Specifications Page 11.03

Mounting Hole Dimensions	Port 4	Gage Port	ALUMINUM		DUCTILE IRON	
			Part Number	List Price	Part Number	List Price
Inch	SAE-6	.25 NPTF	PAP		PAP/S	
Metric	.25 BSPP	.25 BSPP	PAP/M		PAP/T	

S3
T23A

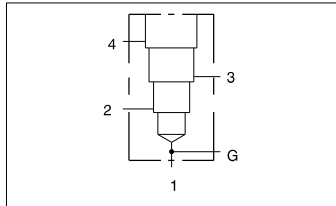

90 degree 1.00" SAE Code 62 flange port body with gage port.

1.00" SAE Code 62
4-Bolt Flange Pattern
3 places.

Mounting Holes:
(opposite side)
Inch: .375-16 UNC-2B x .75 deep.
Metric: M10 x 1.50-6H x .75 deep.
2 places.

T-23A Cavity
Locating Shoulder
Depth 1.69

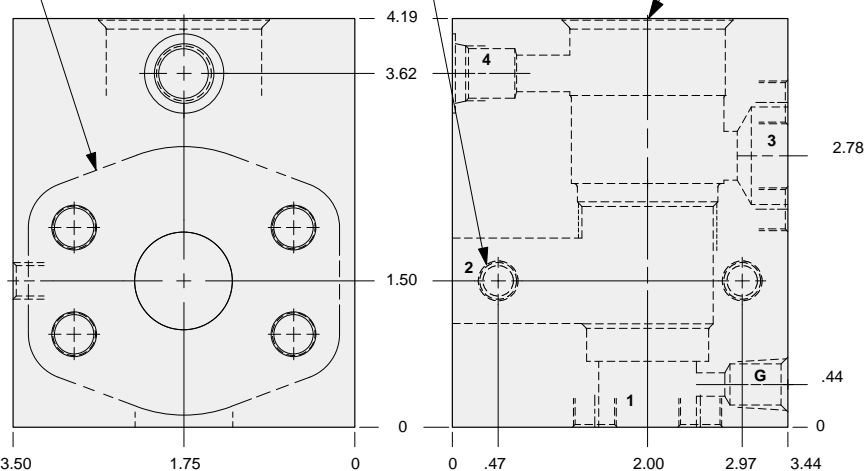

TYPICAL CARTRIDGES USED WITH THIS BODY

RVGD - ***	Page 1.21
PVHA - ***	Page 3.15
PVHB - ***	Page 3.17
CWGA - ***	Page 4.19
CWGG - ***	Page 4.21
CVGV - ***	Page 4.23
FVEA - ***	Page 6.05

Instructions for ordering complete cartridge and body assemblies. Page v

Pressure ratings, material specifications. Page 11.02

SAE Specifications Page 11.03

Mounting Hole Dimensions	Port 4	Gage Port	ALUMINUM		DUCTILE IRON	
			Part Number	List Price	Part Number	List Price
Inch	SAE-6	.25 NPTF	PA4		PA4/S	
Metric	.25 BSPP	.25 BSPP	PA4/M		PA4/T	



LINE MOUNT BODIES



- Aluminum rated to 3000 psi.
- Ductile Iron rated to 5000 psi.

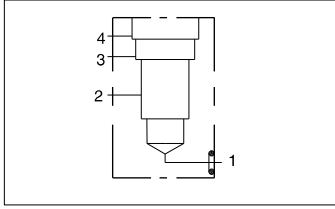

Direct mount 1.00" SAE Code 62 body.

1.00" SAE Code 62
4-Bolt Flange Pattern
2 places.
2 holes tapped
4 holes through

T-23A Cavity
Locating Shoulder
Depth 1.62

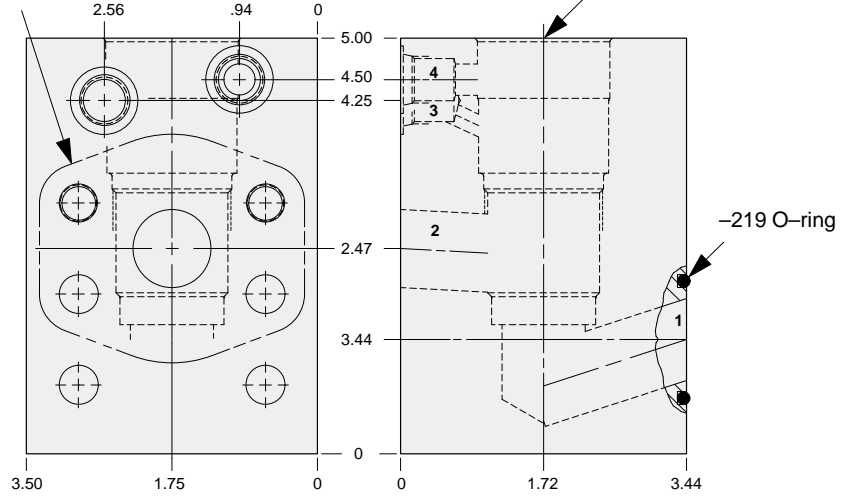

TYPICAL CARTRIDGES USED WITH THIS BODY

- RVGD - *** Page 1.21
CWGA - *** Page 4.19
CWGG - *** Page 4.21
CVGV - *** Page 4.23

S3 T23A Cartridge seal type determines O-ring type.

Instructions for ordering complete cartridge and body assemblies. Page v

Pressure ratings, material specifications. Page 11.02

SAE Specifications Page 11.03

Mounting Hole Dimensions	Ports 3 & 4	ALUMINUM		DUCTILE IRON	
		Part Number	List Price	Part Number	List Price
Inch	SAE-6	WHA		WHA/S	
Metric	.25 BSPP	WHA/M		WHA/T	



LINE MOUNT BODIES



- Aluminum rated to 3000 psi.
- Ductile Iron rated to 5000 psi.

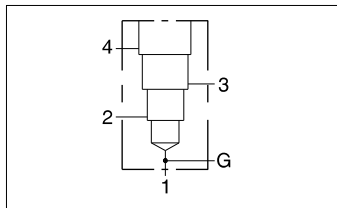

90 degree 1.25" SAE Code 61 flange port body with gage port.

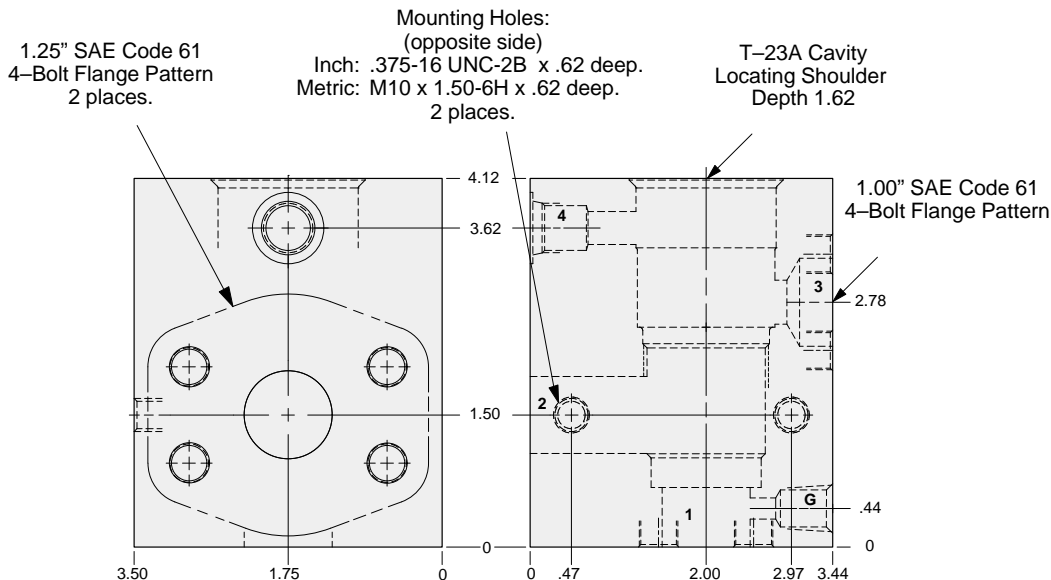

S3
T23A

TYPICAL CARTRIDGES USED WITH THIS BODY

RVGD - ***	Page 1.21
PVHA - ***	Page 3.15
PVHB - ***	Page 3.17
CWGA - ***	Page 4.19
CWGG - ***	Page 4.21
CVGV - ***	Page 4.23
FVEA - ***	Page 6.05

Instructions for ordering complete cartridge and body assemblies. Page v

Pressure ratings, material specifications. Page 11.02

SAE Specifications Page 11.03

Mounting Hole Dimensions	Port 4	Gage Port	ALUMINUM		DUCTILE IRON	
			Part Number	List Price	Part Number	List Price
Inch	SAE-6	.25 NPTF	PAQ		PAQ/S	
Metric	.25 BSPP	.25 BSPP	PAQ/M		PAQ/T	

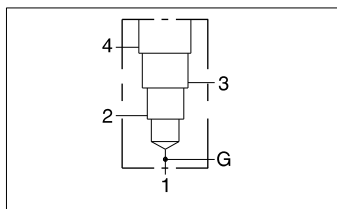

90 degree 1.25" SAE Code 62 flange port body with gage port.

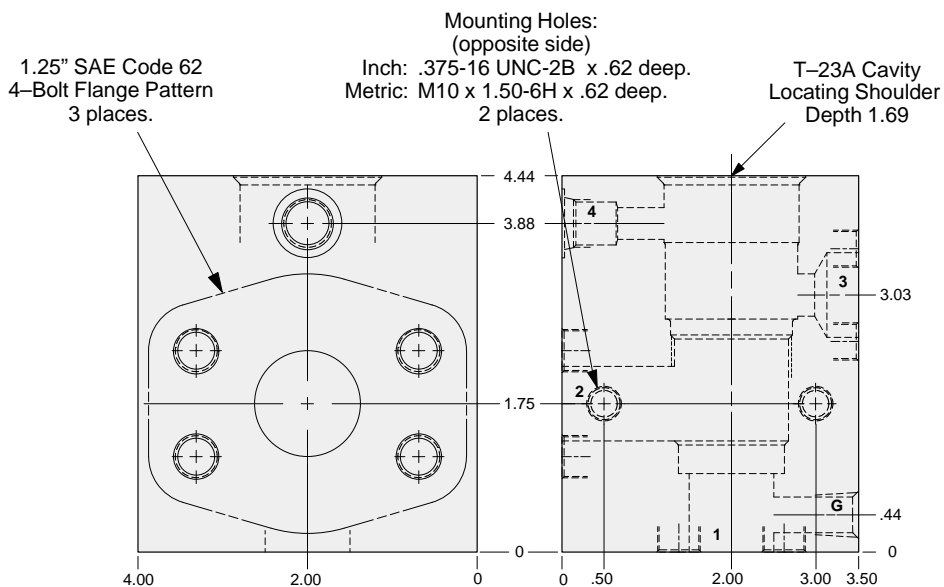

TYPICAL CARTRIDGES USED WITH THIS BODY

RVGD - ***	Page 1.21
PVHA - ***	Page 3.15
PVHB - ***	Page 3.17
CWGA - ***	Page 4.19
CWGG - ***	Page 4.21
CVGV - ***	Page 4.23
FVEA - ***	Page 6.05

Instructions for ordering complete cartridge and body assemblies. Page v

Pressure ratings, material specifications. Page 11.02

SAE Specifications Page 11.03

Mounting Hole Dimensions	Port 4	Gage Port	ALUMINUM		DUCTILE IRON	
			Part Number	List Price	Part Number	List Price
Inch	SAE-6	.25 NPTF	PA5		PA5/S	
Metric	.25 BSPP	.25 BSPP	PA5/M		PA5/T	



LINE MOUNT BODIES



- Aluminum rated to 3000 psi.
- Ductile Iron rated to 5000 psi.

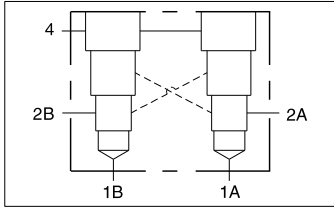

Two cavity 90 degree cross-piloted body with common port 4 for load control applications.

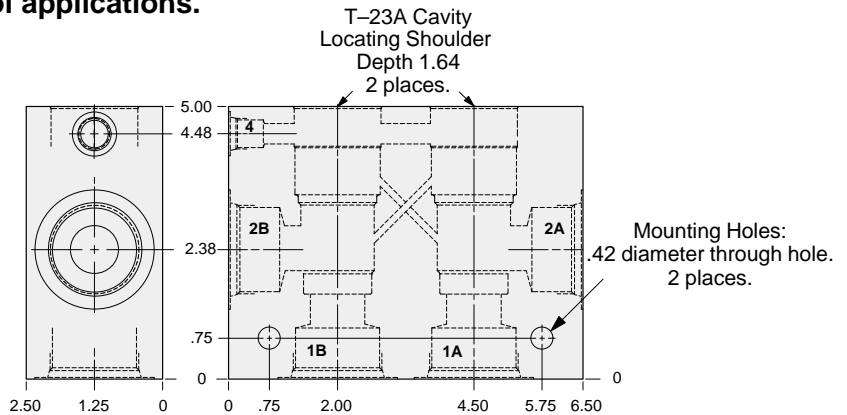

TYPICAL CARTRIDGES USED WITH THIS BODY

- CWGA - *** Page 4.19
 CWGG - *** Page 4.21
 CVGV - *** Page 4.23

S3 T23A Instructions for ordering complete cartridge and body assemblies. Page v

Pressure ratings, material specifications. Page 11.02

Ports 1 A, 1 B 2 A, 2 B	Port 4	ALUMINUM		DUCTILE IRON	
		Part Number	List Price	Part Number	List Price
.75 NPTF	.25 NPTF	XMD		XMD/S	
1.00 NPTF	.25 NPTF	XME		XME/S	
1.25 NPTF	.25 NPTF	XMF		XMF/S	
SAE-12	SAE-6	XML		XML/S	
SAE-16	SAE-6	XMM		XMM/S	
SAE-20	SAE-6	XMN		XMN/S	
.75 BSPP	.25 BSPP	XMW		XMW/S	
1.00 BSPP	.25 BSPP	XXM		XXM/S	
1.25 BSPP	.25 BSPP	XMY		XMY/S	

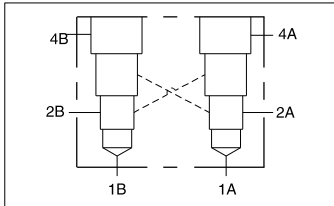

Two cavity 90 degree cross-piloted body with independent port 4 for load control applications.

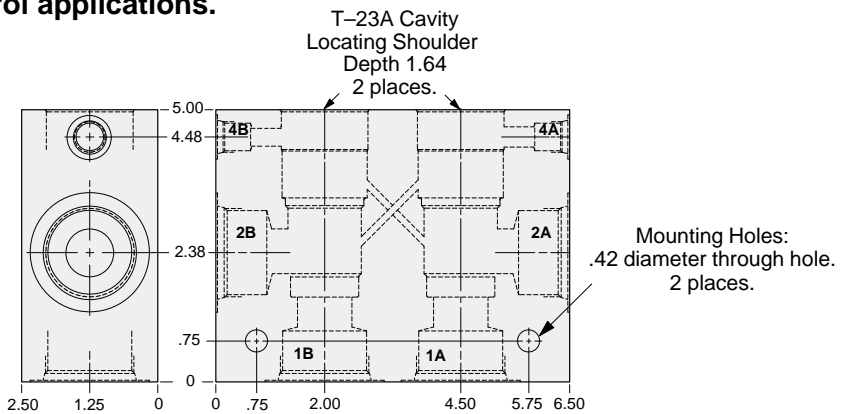

TYPICAL CARTRIDGES USED WITH THIS BODY

- CWGA - *** Page 4.19
 CWGG - *** Page 4.21
 CVGV - *** Page 4.23

Instructions for ordering complete cartridge and body assemblies. Page v

Pressure ratings, material specifications. Page 11.02

Ports 1 A, 1 B 2 A, 2 B	Ports 4A, 4B	ALUMINUM		DUCTILE IRON	
		Part Number	List Price	Part Number	List Price
.75 NPTF	.25 NPTF	VAD		VAD/S	
1.00 NPTF	.25 NPTF	VAE		VAE/S	
1.25 NPTF	.25 NPTF	VAF		VAF/S	
SAE-12	SAE-6	VAL		VAL/S	
SAE-16	SAE-6	VAM		VAM/S	
SAE-20	SAE-6	VAN		VAN/S	
.75 BSPP	.25 BSPP	VAW		VAW/S	
1.00 BSPP	.25 BSPP	VAX		VAX/S	
1.25 BSPP	.25 BSPP	VAY		VAY/S	



LINE MOUNT BODIES



- Aluminum rated to 3000 psi.
- Ductile Iron rated to 5000 psi.

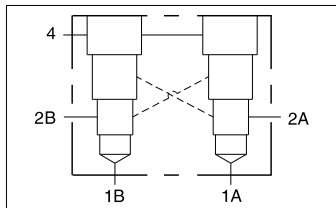

Two cavity cross-piloted 1.00" SAE Code 61 flange port body with common port 4 for load control applications.

1.00" SAE Code 61
4-Bolt Flange Pattern
4 places.

Mounting Holes:
(opposite side)
Inch: .375-16 UNC-2B
x .62 deep.
Metric: M10 x 1.50-6H
x .62 deep.
2 places.

T-23A Cavity
Locating Shoulder
Depth 1.64
2 places.

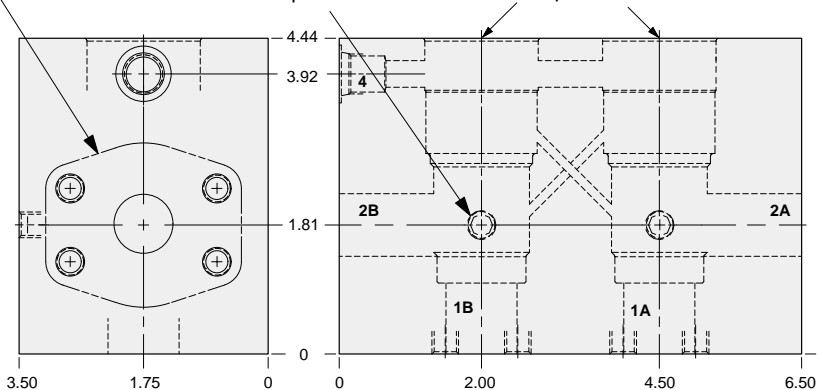

TYPICAL CARTRIDGES USED WITH THIS BODY

CWGA - *** Page 4.19
CWGG - *** Page 4.21
CVGV - *** Page 4.23

Instructions for ordering complete cartridge and body assemblies. Page v

Pressure ratings, material specifications. Page 11.02

SAE Specifications Page 11.03

Mounting Hole Dimensions	Port 4	ALUMINUM		DUCTILE IRON	
		Part Number	List Price	Part Number	List Price
Inch	SAE-6	XMP		XMP/S	
Metric	.25 BSPP	XMP/M		XMP/T	

S3
T23A

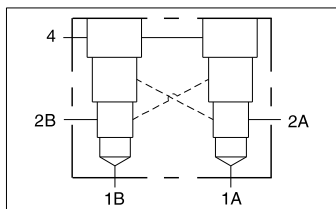

Two cavity cross-piloted 1.00" SAE Code 62 flange port body with common port 4 for load control applications.

1.00" SAE Code 62
4-Bolt Flange Pattern
4 places.

Mounting Holes:
(opposite side)
Inch: .375-16 UNC-2B
x .62 deep.
Metric: M10 x 1.50-6H
x .62 deep.
2 places.

T-23A Cavity
Locating Shoulder
Depth 1.64
2 places.

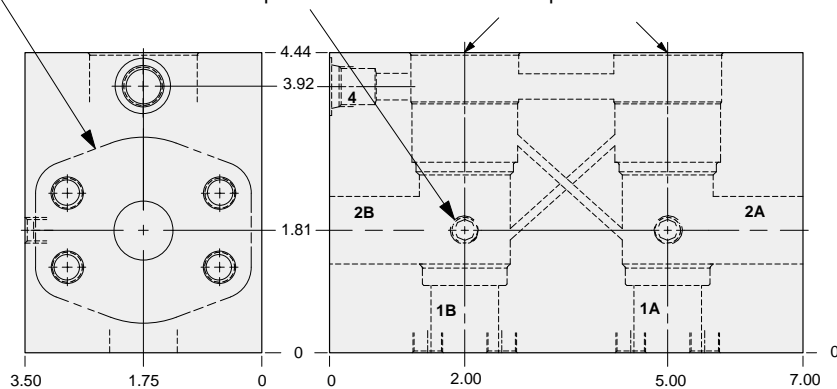

TYPICAL CARTRIDGES USED WITH THIS BODY

CWGA - *** Page 4.19
CWGG - *** Page 4.21
CVGV - *** Page 4.23

Instructions for ordering complete cartridge and body assemblies. Page v

Pressure ratings, material specifications. Page 11.02

SAE Specifications Page 11.03

Mounting Hole Dimensions	Port 4	ALUMINUM		DUCTILE IRON	
		Part Number	List Price	Part Number	List Price
Inch	SAE-6	XM4		XM4/S	
Metric	.25 BSPP	XM4/M		XM4/T	



LINE MOUNT BODIES



- Aluminum rated to 3000 psi.
- Ductile Iron rated to 5000 psi.

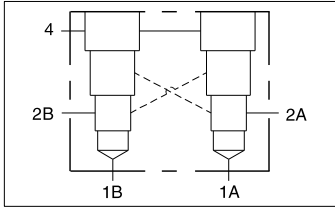

Two cavity cross-piloted 1.25" SAE Code 61 flange port body with common port 4 for load control applications.

TYPICAL CARTRIDGES USED WITH THIS BODY

- CWGA - *** Page 4.19
 CWGG - *** Page 4.21
 CVGV - *** Page 4.23

S3 T23A Instructions for ordering complete cartridge and body assemblies. Page v

Pressure ratings, material specifications. Page 11.02

SAE Specifications Page 11.03

Mounting Holes:
 (opposite side)
 Inch: .375-16 UNC-2B
 x .62 deep.
 Metric: M10 x 1.50-6H
 x .62 deep.
 2 places.

1.25" SAE Code 61
 4-Bolt Flange Pattern
 4 places.

T-23A Cavity
 Locating Shoulder
 Depth 1.64
 2 places.

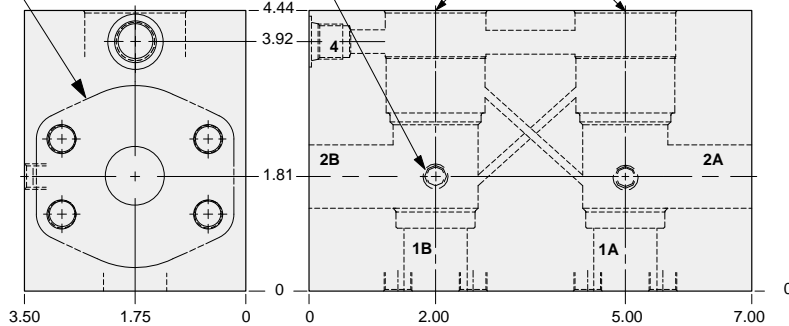

Mounting Hole Dimensions	Port 4	ALUMINUM		DUCTILE IRON	
		Part Number	List Price	Part Number	List Price
Inch	SAE-6	XMQ		XMQ/S	
Metric	.25 BSPP	XMQ/M		XMQ/T	

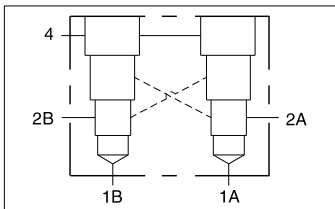

Two cavity cross-piloted 1.25" SAE Code 62 flange port body with common port 4 for load control applications.

TYPICAL CARTRIDGES USED WITH THIS BODY

- CWGA - *** Page 4.19
 CWGG - *** Page 4.21
 CVGV - *** Page 4.23

Instructions for ordering complete cartridge and body assemblies. Page v

Pressure ratings, material specifications. Page 11.02

SAE Specifications Page 11.03

Mounting Holes:
 (opposite side)
 Inch: .375-16 UNC-2B
 x .62 deep.
 Metric: M10 x 1.50-6H
 x .62 deep.
 2 places.

1.25" SAE Code 62
 4-Bolt Flange Pattern
 4 places.

T-23A Cavity
 Locating Shoulder
 Depth 1.64
 2 places.

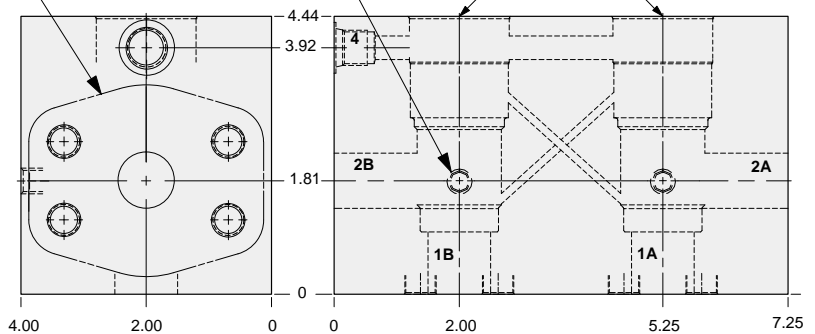

Mounting Hole Dimensions	Port 4	ALUMINUM		DUCTILE IRON	
		Part Number	List Price	Part Number	List Price
Inch	SAE-6	XM5		XM5/S	
Metric	.25 BSPP	XM5/M		XM5/T	



LINE MOUNT BODIES



- Aluminum rated to 3000 psi.
- Ductile Iron rated to 5000 psi.

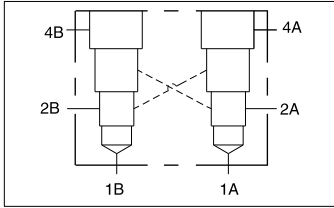

Two cavity cross-piloted 1.00" SAE Code 61 flange port body with independent port 4 for load control applications.

TYPICAL CARTRIDGES USED WITH THIS BODY

CWGA - *** Page 4.19
 CWGG - *** Page 4.21
 CVGV - *** Page 4.23

Instructions for ordering complete cartridge and body assemblies. Page v

Pressure ratings, material specifications. Page 11.02

SAE Specifications Page 11.03

Mounting Holes:
 (opposite side)
 Inch: .375-16 UNC-2B
 x .62 deep.
 Metric: M10 x 1.50-6H
 x .62 deep.
 2 places.

1.00" SAE Code 61
 4-Bolt Flange Pattern
 4 places.

T-23A Cavity
 Locating Shoulder
 Depth 1.64
 2 places.

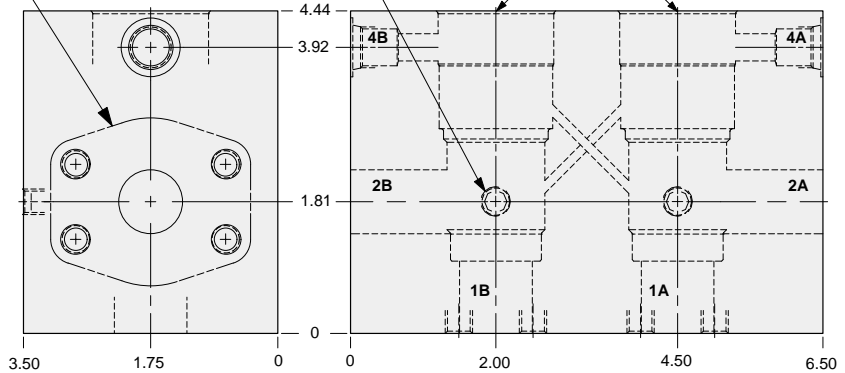

Mounting Hole Dimensions	Ports 4A, 4B	ALUMINUM		DUCTILE IRON	
		Part Number	List Price	Part Number	List Price
Inch	SAE-6	VAP		VAP/S	
Metric	.25 BSPP	VAP/M		VAP/T	

S3
T23A

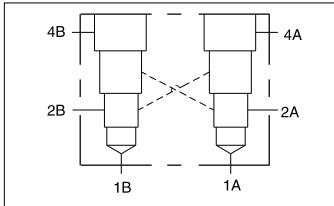

Two cavity cross-piloted 1.00" SAE Code 62 flange port body with independent port 4 for load control applications.

TYPICAL CARTRIDGES USED WITH THIS BODY

CWGA - *** Page 4.19
 CWGG - *** Page 4.21
 CVGV - *** Page 4.23

Instructions for ordering complete cartridge and body assemblies. Page v

Pressure ratings, material specifications. Page 11.02

SAE Specifications Page 11.03

Mounting Holes:
 (opposite side)
 Inch: .375-16 UNC-2B
 x .62 deep.
 Metric: M10 x 1.50-6H
 x .62 deep.
 2 places.

1.00" SAE Code 62
 4-Bolt Flange Pattern
 4 places.

T-23A Cavity
 Locating Shoulder
 Depth 1.64
 2 places.

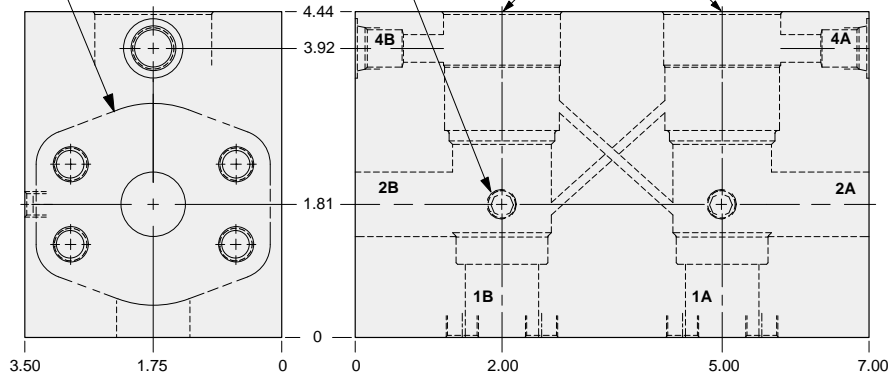

Mounting Hole Dimensions	Ports 4A, 4B	ALUMINUM		DUCTILE IRON	
		Part Number	List Price	Part Number	List Price
Inch	SAE-6	VA4		VA4/S	
Metric	.25 BSPP	VA4/M		VA4/T	



LINE MOUNT BODIES



- Aluminum rated to 3000 psi.
- Ductile Iron rated to 5000 psi.

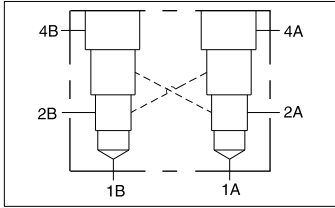

Two cavity cross-piloted 1.25" SAE Code 61 flange port body with independent port 4 for load control applications.

TYPICAL CARTRIDGES USED WITH THIS BODY

- CWGA - *** Page 4.19
 CWGG - *** Page 4.21
 CVGV - *** Page 4.23

S3 T23A Instructions for ordering complete cartridge and body assemblies. Page v

Pressure ratings, material specifications. Page 11.02

SAE Specifications Page 11.03

1.25" SAE Code 61
 4-Bolt Flange Pattern
 4 places.

Mounting Holes:
 (opposite side)
 Inch: .375-16 UNC-2B
 x .62 deep.
 Metric: M10 x 1.50-6H
 x .62 deep.
 2 places.

T-23A Cavity
 Locating Shoulder
 Depth 1.64
 2 places.

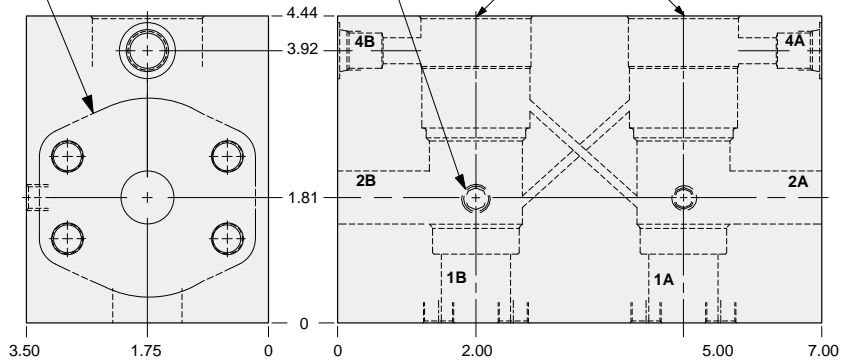

Mounting Hole Dimensions	Ports 4A, 4B	ALUMINUM		DUCTILE IRON	
		Part Number	List Price	Part Number	List Price
Inch	SAE-6	VAQ		VAQ/S	
Metric	.25 BSPP	VAQ/M		VAQ/T	

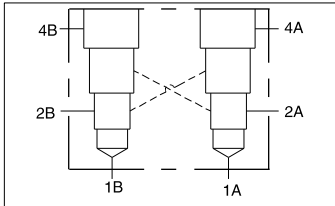

Two cavity cross-piloted 1.25" SAE Code 62 flange port body with independent port 4 for load control applications.

TYPICAL CARTRIDGES USED WITH THIS BODY

- CWGA - *** Page 4.19
 CWGG - *** Page 4.21
 CVGV - *** Page 4.23

Instructions for ordering complete cartridge and body assemblies. Page v

Pressure ratings, material specifications. Page 11.02

SAE Specifications Page 11.03

1.25" SAE Code 62
 4-Bolt Flange Pattern
 4 places.

Mounting Holes:
 (opposite side)
 Inch: .375-16 UNC-2B
 x .62 deep.
 Metric: M10 x 1.50-6H
 x .62 deep.
 2 places.

T-23A Cavity
 Locating Shoulder
 Depth 1.64
 2 places.

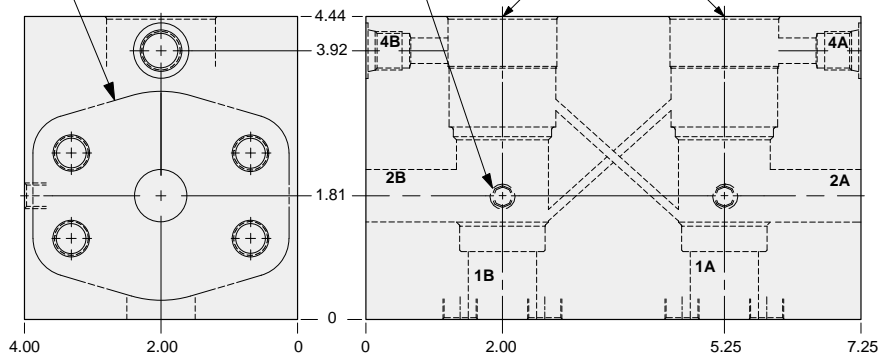

Mounting Hole Dimensions	Ports 4A, 4B	ALUMINUM		DUCTILE IRON	
		Part Number	List Price	Part Number	List Price
Inch	SAE-6	VA5		VA5/S	
Metric	.25 BSPP	VA5/M		VA5/T	



LINE MOUNT BODIES



- Aluminum rated to 3000 psi.
- Ductile Iron rated to 5000 psi.

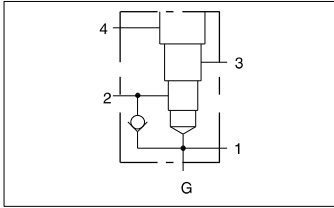

Body with reverse free flow check and gage port for reducing/relieving applications.

T-23A Cavity Locating Shoulder Depth 1.62

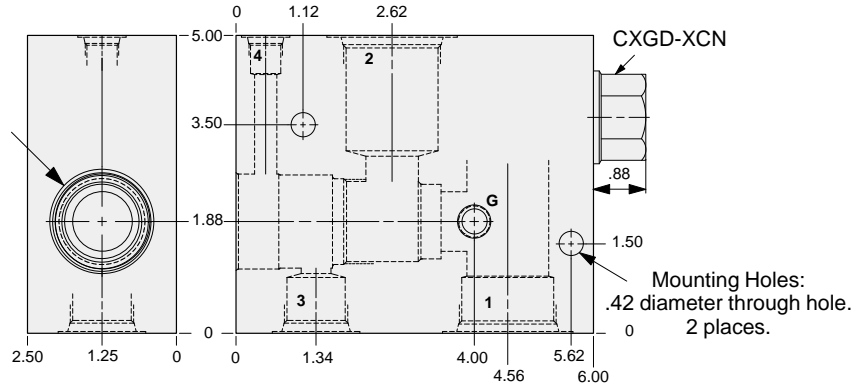

TYPICAL CARTRIDGES USED WITH THIS BODY

PVHA - *** Page 3.15
PVHB - *** Page 3.17

Cartridge seal type determines check valve seal type.

Instructions for ordering complete cartridge and body assemblies. Page v

Pressure ratings, material specifications. Page 11.02

Ports 1 & 2	Port 3	Port 4	Gage Port	ALUMINUM		DUCTILE IRON	
				Part Number	List Price	Part Number	List Price
.75 NPTF	.75 NPTF	.25 NPTF	.25 NPTF	P4D		P4D/S	
1.00 NPTF	.75 NPTF	.25 NPTF	.25 NPTF	P4E		P4E/S	
1.25 NPTF	.75 NPTF	.25 NPTF	.25 NPTF	P4F		P4F/S	
SAE-12	SAE-12	SAE-6	.25 NPTF	P4L		P4L/S	
SAE-16	SAE-12	SAE-6	.25 NPTF	P4M		P4M/S	
SAE-20	SAE-12	SAE-6	.25 NPTF	P4N		P4N/S	
.75 BSPP	.75 BSPP	.25 BSPP	.25 BSPP	P4W		P4W/S	
1.00 BSPP	.75 BSPP	.25 BSPP	.25 BSPP	P4X		P4X/S	
1.25 BSPP	.75 BSPP	.25 BSPP	.25 BSPP	P4Y		P4Y/S	

S3
T23A



LINE MOUNT BODIES



- Aluminum rated to 3000 psi.
- Ductile Iron rated to 5000 psi.

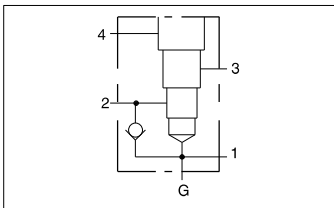

1.00" SAE Code 61 flange port body with reverse free flow check and gage port for reducing/relieving applications.

1.00" SAE Code 61
4-Bolt Flange Pattern
3 places.

Mounting Holes:
Inch: .375-16 UNC-2B
x .62 deep.
Metric: M10 x 1.50-6H
x .62 deep.
2 places.

T-23A Cavity
Locating Shoulder
Depth 1.72

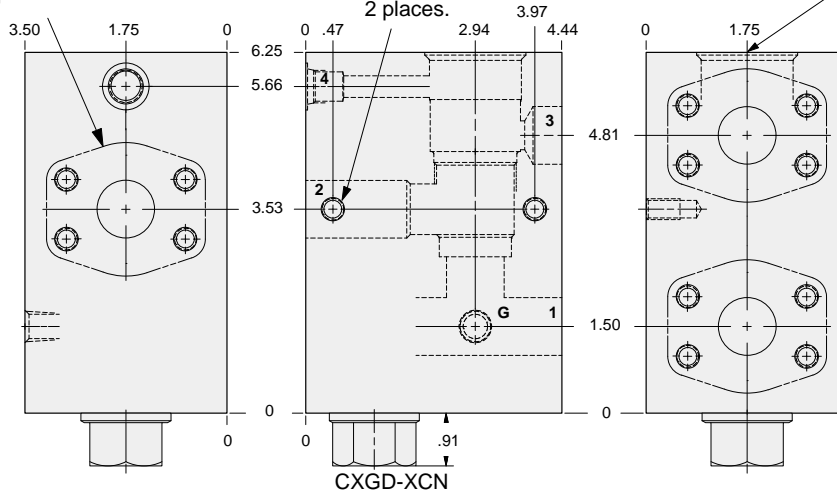

TYPICAL CARTRIDGES USED WITH THIS BODY

PVHA - *** Page 3.15
PVHB - *** Page 3.17

Cartridge seal type determines check valve seal type.

Instructions for ordering complete cartridge and body assemblies. Page v

Pressure ratings, material specifications. Page 11.02

SAE Specifications Page 11.03

Mounting Hole Dimensions	Port 4	Gage Port	ALUMINUM		DUCTILE IRON	
			Part Number	List Price	Part Number	List Price
Inch	SAE-6	.25 NPTF	P4P		P4P/S	
Metric	.25 BSPP	.25 BSPP	P4P/M		P4P/T	

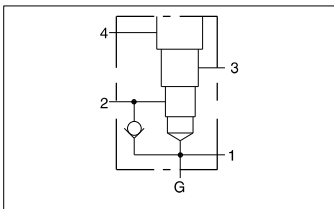

1.00" SAE Code 62 flange port body with reverse free flow check and gage port for reducing/relieving applications.

1.00" SAE Code 62
4-Bolt Flange Pattern
3 places.

Mounting Holes:
Inch: .375-16 UNC-2B
x .62 deep.
Metric: M10 x 1.50-6H
x .62 deep.
2 places.

T-23A Cavity
Locating Shoulder
Depth 1.72

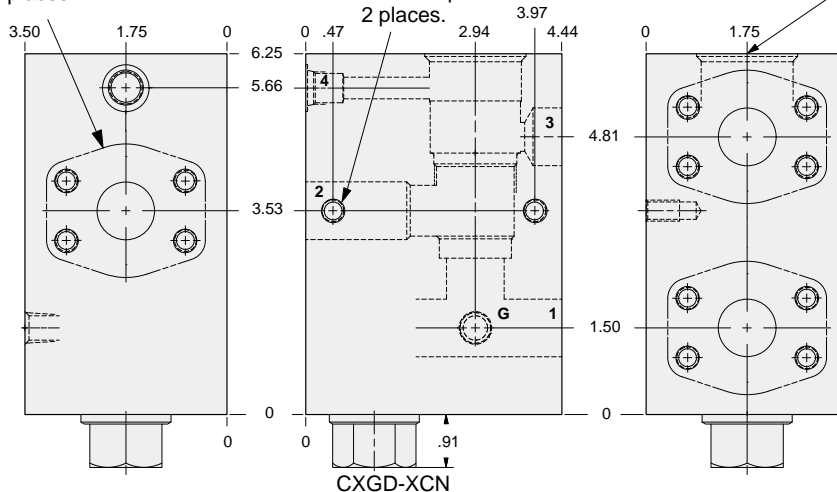

TYPICAL CARTRIDGES USED WITH THIS BODY

PVHA - *** Page 3.15
PVHB - *** Page 3.17

Cartridge seal type determines check valve seal type.

Instructions for ordering complete cartridge and body assemblies. Page v

Pressure ratings, material specifications. Page 11.02

SAE Specifications Page 11.03

Mounting Hole Dimensions	Port 4	Gage Port	ALUMINUM		DUCTILE IRON	
			Part Number	List Price	Part Number	List Price
Inch	SAE-6	.25 NPTF	P44		P44/S	
Metric	.25 BSPP	.25 BSPP	P44/M		P44/T	



LINE MOUNT BODIES



- Aluminum rated to 3000 psi.
- Ductile Iron rated to 5000 psi.

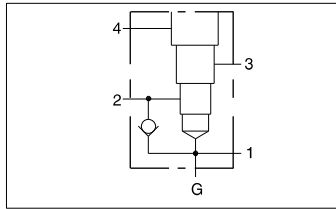

1.25" SAE Code 61 flange port body with reverse free flow check and gage port for reducing/relieving applications.

TYPICAL CARTRIDGES USED WITH THIS BODY

PVHA - *** Page 3.15
 PVHB - *** Page 3.17

Cartridge seal type determines check valve seal type.

Instructions for ordering complete cartridge and body assemblies. Page v

Pressure ratings, material specifications. Page 11.02

SAE Specifications Page 11.03

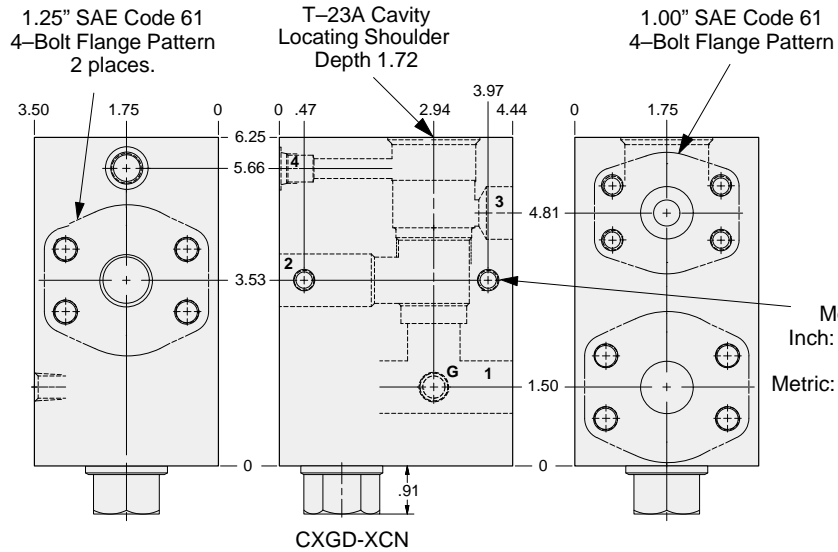

Mounting Hole Dimensions	Port 3 SAE Code 61	Port 4	Gage Port	ALUMINUM		DUCTILE IRON	
				Part Number	List Price	Part Number	List Price
Inch	1.00"	SAE-6	.25 NPTF	P4Q		P4Q/S	
Metric	1.00"	.25 BSPP	.25 BSPP	P4Q/M		P4Q/T	

S3
T23A

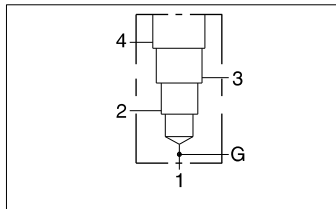

1.25" SAE Code 62 flange port body with reverse free flow check and gage port for reducing/relieving applications.

TYPICAL CARTRIDGES USED WITH THIS BODY

PVHA - *** Page 3.15
 PVHB - *** Page 3.17

Cartridge seal type determines check valve seal type.

Instructions for ordering complete cartridge and body assemblies. Page v

Pressure ratings, material specifications. Page 11.02

SAE Specifications Page 11.03

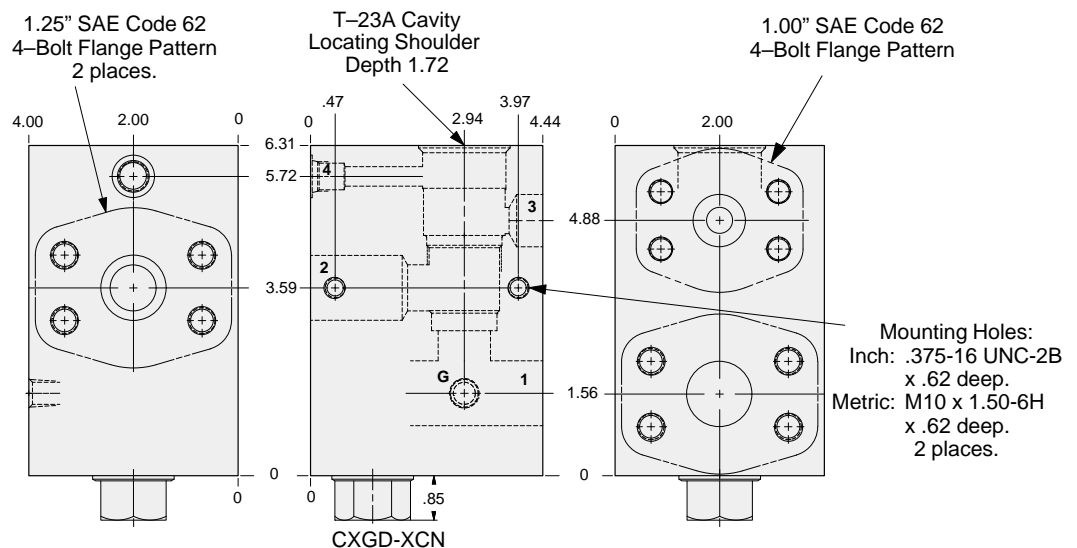

Mounting Hole Dimensions	Port 3 SAE Code 62	Port 4	Gage Port	ALUMINUM		DUCTILE IRON	
				Part Number	List Price	Part Number	List Price
Inch	1.00"	SAE-6	.25 NPTF	P45		P45/S	
Metric	1.00"	.25 BSPP	.25 BSPP	P45/M		P45/T	



LINE MOUNT BODIES



- Aluminum rated to 3000 psi.
- Ductile Iron rated to 5000 psi.

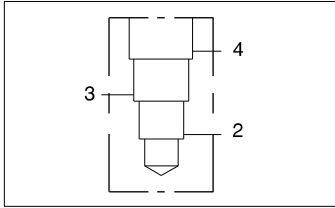

Body for flow divider/combiner applications.

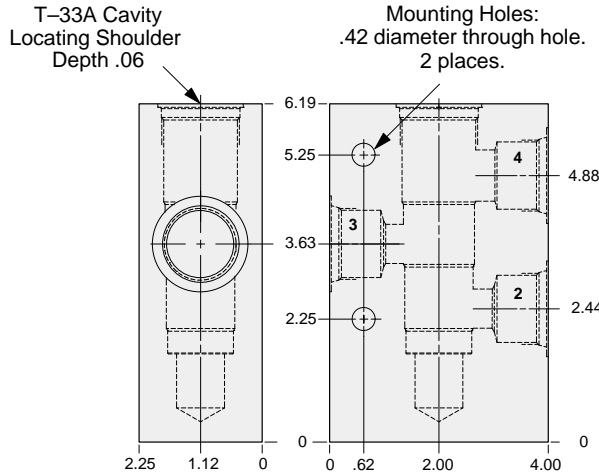

TYPICAL CARTRIDGES USED WITH THIS BODY

- FSED - *** Page 7.09
- FSEA - *** Page 7.11
- FSES - *** Page 7.13
- FSEH - *** Page 7.15
- DSGH - *** Page 10.07

Instructions for ordering complete cartridge and body assemblies. Page v

Pressure ratings, material specifications. Page 11.02

S3
T33A

Ports 2, 3, & 4	ALUMINUM		DUCTILE IRON	
	Part Number	List Price	Part Number	List Price
.75 NPTF	PMD		PMD/S	
1.00 NPTF	PME		PME/S	
SAE-12	PML		PML/S	
SAE-16	PMM		PMM/S	
.75 BSPP	PMW		PMW/S	
1.00 BSPP	PMX		PMX/S	

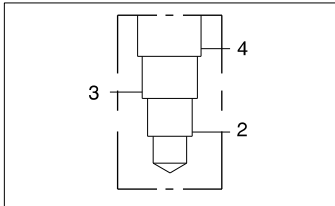

Body for flow divider/combiner applications.

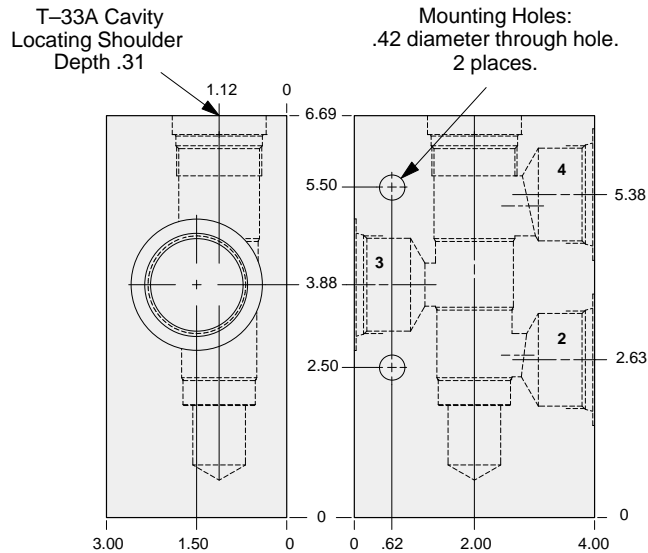

TYPICAL CARTRIDGES USED WITH THIS BODY

- FSED - *** Page 7.09
- FSEA - *** Page 7.11
- FSES - *** Page 7.13
- FSEH - *** Page 7.15
- DSGH - *** Page 10.07

Instructions for ordering complete cartridge and body assemblies. Page v

Pressure ratings, material specifications. Page 11.02

Ports 2, 3, & 4	ALUMINUM		DUCTILE IRON	
	Part Number	List Price	Part Number	List Price
1.25 NPTF	PMF		PMF/S	
SAE-20	PMN		PMN/S	
1.25 BSPP	PMY		PMY/S	



LINE MOUNT BODIES



- Aluminum rated to 3000 psi.
- Ductile Iron rated to 5000 psi.

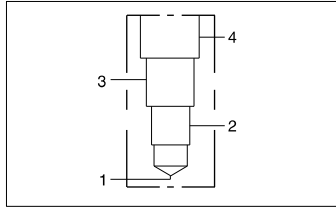

Four-port body.

T-33A Cavity
Locating Shoulder
Depth .06

Mounting Holes:
.42 diameter through hole.
2 places.

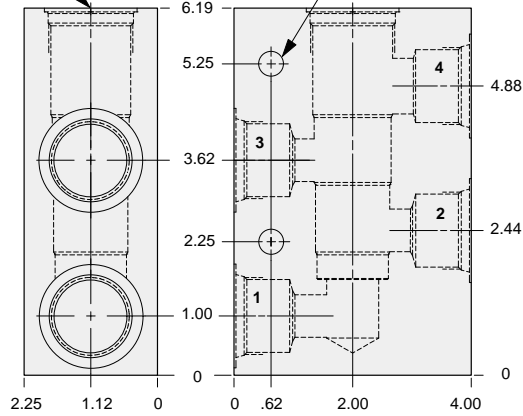

Instructions for ordering complete cartridge and body assemblies. Page v

Pressure ratings, material specifications. Page 11.02

Ports 1 & 2, 3 & 4	ALUMINUM		DUCTILE IRON	
	Part Number	List Price	Part Number	List Price
.75 NPTF	PND		PND/S	
1.00 NPTF	PNE		PNE/S	
SAE-12	PNL		PNL/S	
SAE-16	PNM		PNM/S	
.75 BSPP	PNW		PNW/S	
1.00 BSPP	PNX		PNX/S	

S3
T33A

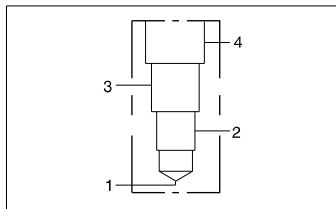

Four-port body.

T-33A Cavity
Locating Shoulder
Depth .31

Mounting Holes:
.42 diameter through hole.
2 places.

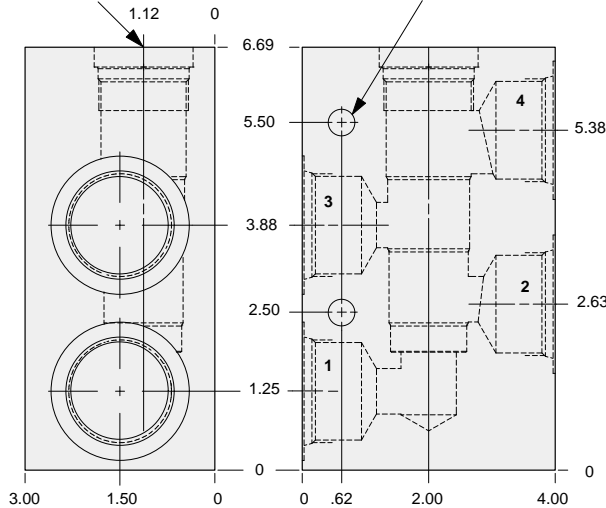

Instructions for ordering complete cartridge and body assemblies. Page v

Pressure ratings, material specifications. Page 11.02

Ports 1 & 2, 3 & 4	ALUMINUM		DUCTILE IRON	
	Part Number	List Price	Part Number	List Price
1.25 NPTF	PNF		PNF/S	
SAE-20	PNN		PNN/S	
1.25 BSPP	PNY		PNY/S	



LINE MOUNT BODIES



- Aluminum rated to 3000 psi.
- Ductile Iron rated to 5000 psi.

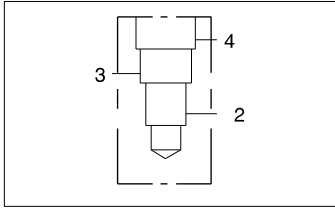

1.00" SAE Code 61 flange port body for flow divider/combiner applications.

1.00" SAE Code 61
4-Bolt Flange Pattern
3 places.

T-33A Cavity
Locating Shoulder
Depth .06

Mounting Holes:
Inch: .375-16 UNC-2B
x .62 deep.
Metric: M10 x 1.50-6H
x .62 deep.
2 places.

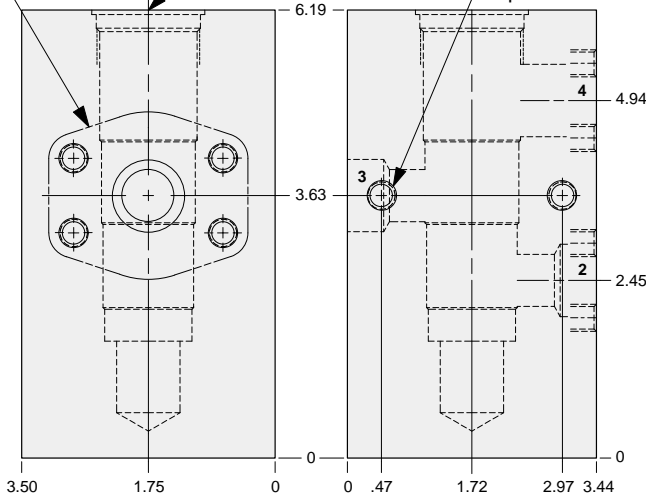

TYPICAL CARTRIDGES USED WITH THIS BODY

- FSED - *** Page 7.09
FSEA - *** Page 7.11
FSES - *** Page 7.13
FSEH - *** Page 7.15
DSGH - *** Page 10.07

Instructions for ordering complete cartridge and body assemblies. Page v

Pressure ratings, material specifications. Page 11.02

SAE Specifications Page 11.03

S3
T33A

Mounting Hole Dimensions	ALUMINUM		DUCTILE IRON	
	Part Number	List Price	Part Number	List Price
Inch	PMP		PMP/S	
Metric	PMP/M		PMP/T	

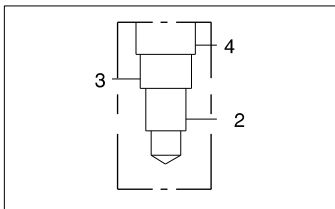

1.00" SAE Code 62 flange port body for flow divider/combiner applications.

1.00" SAE Code 62
4-Bolt Flange Pattern
3 places.

T-33A Cavity
Locating Shoulder
Depth .56

Mounting Holes:
Inch: .375-16 UNC-2B
x .62 deep.
Metric: M10 x 1.50-6H
x .62 deep.
2 places.

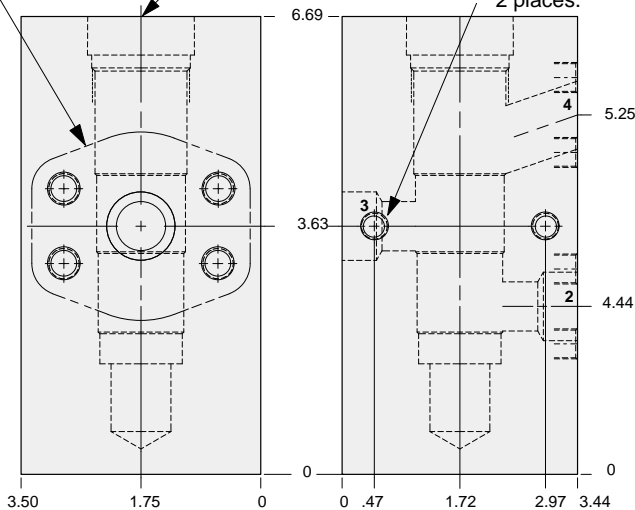

TYPICAL CARTRIDGES USED WITH THIS BODY

- FSED - *** Page 7.09
FSEA - *** Page 7.11
FSES - *** Page 7.13
FSEH - *** Page 7.15
DSGH - *** Page 10.07

Instructions for ordering complete cartridge and body assemblies. Page v

Pressure ratings, material specifications. Page 11.02

SAE Specifications Page 11.03

Mounting Hole Dimensions	ALUMINUM		DUCTILE IRON	
	Part Number	List Price	Part Number	List Price
Inch	PM4		PM4/S	
Metric	PM4/M		PM4/T	



LINE MOUNT BODIES



- Aluminum rated to 3000 psi.
- Ductile Iron rated to 5000 psi.

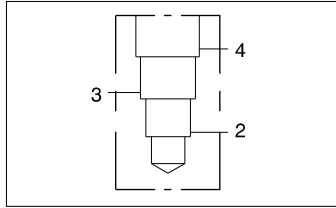

1.25" SAE Code 61 flange port body for flow divider/combiner applications.

1.25" SAE Code 61
4-Bolt Flange Pattern

T-33A Cavity
Locating Shoulder
Depth .06

Mounting Holes:
Inch: .375-16 UNC-2B
x .62 deep.
Metric: M10 x 1.50-6H
x .62 deep.
2 places.

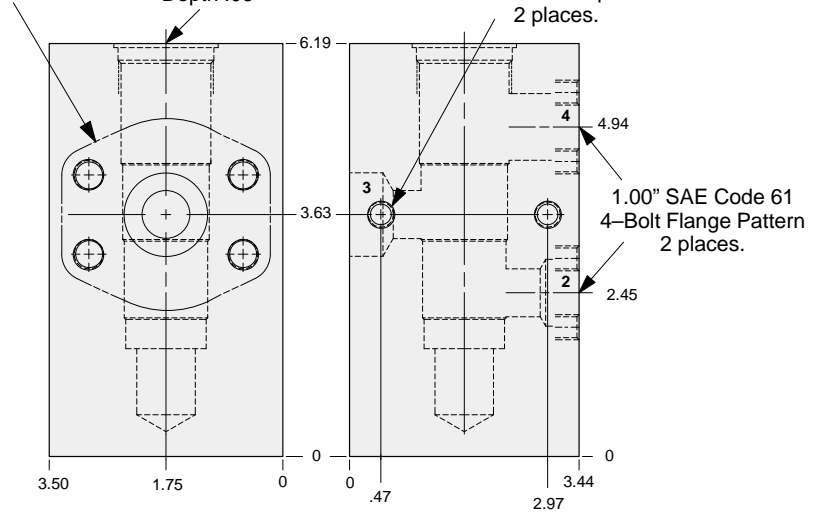

TYPICAL CARTRIDGES USED WITH THIS BODY

- FSED - *** Page 7.09
- FSEA - *** Page 7.11
- FSES - *** Page 7.13
- FSEH - *** Page 7.15
- DSGH - *** Page 10.07

Instructions for ordering complete cartridge and body assemblies. Page v

Pressure ratings, material specifications. Page 11.02

SAE Specifications Page 11.03

Mounting Hole Dimensions	Ports 2 & 4 SAE Code 61	ALUMINUM		DUCTILE IRON	
		Part Number	List Price	Part Number	List Price
Inch	1.00"	PMQ		PMQ/S	
Metric	1.00"	PMQ/M		PMQ/T	

S3
T33A

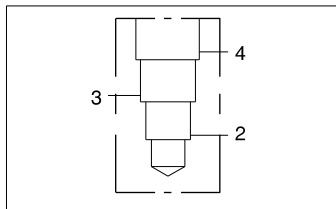

1.25" SAE Code 62 flange port body for flow divider/combiner applications.

1.25" SAE Code 62
4-Bolt Flange Pattern

T-33A Cavity
Locating Shoulder
Depth .56

Mounting Holes:
Inch: .375-16 UNC-2B
x .62 deep.
Metric: M10 x 1.50-6H
x .62 deep.
2 places.

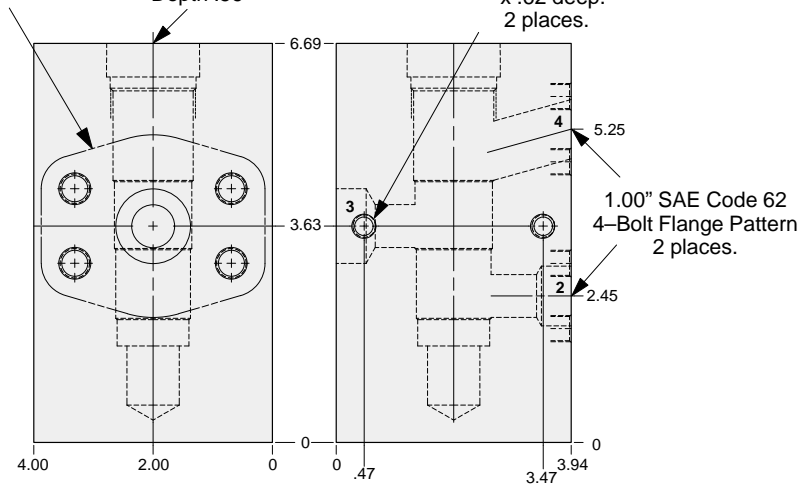

TYPICAL CARTRIDGES USED WITH THIS BODY

- FSED - *** Page 7.09
- FSEA - *** Page 7.11
- FSES - *** Page 7.13
- FSEH - *** Page 7.15
- DSGH - *** Page 10.07

Instructions for ordering complete cartridge and body assemblies. Page v

Pressure ratings, material specifications. Page 11.02

SAE Specifications Page 11.03

Mounting Hole Dimensions	Ports 2 & 4 SAE Code 62	ALUMINUM		DUCTILE IRON	
		Part Number	List Price	Part Number	List Price
Inch	1.00"	PM5		PM5/S	
Metric	1.00"	PM5/M		PM5/T	



LINE MOUNT BODIES



- Aluminum rated to 3000 psi.
- Ductile Iron rated to 5000 psi.

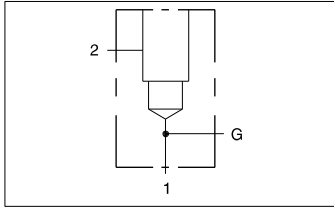

90 degree body with gage port.

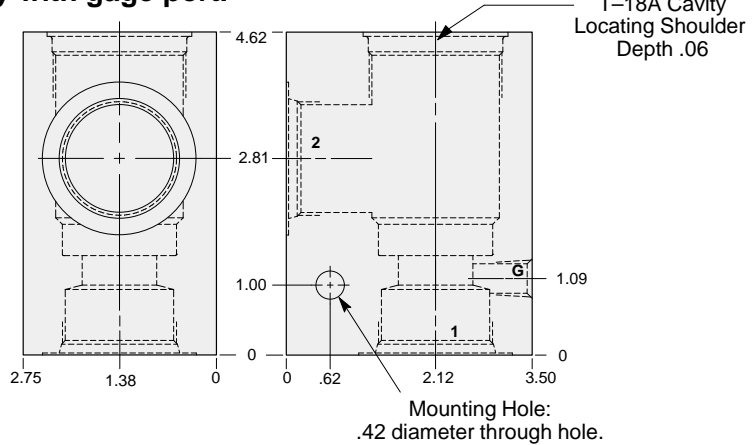

TYPICAL CARTRIDGES USED WITH THIS BODY

RPKC - ***	Page 1.07
RPKE - ***	Page 1.09
RDJA - ***	Page 1.11
RQKB - ***	Page 1.13
RPKD - ***	Page 1.15
CXJA - ***	Page 5.09
CXID - ***	Page 5.11
NFFC - ***	Page 5.13
CNIC - ***	Page 5.15
NCGB - ***	Page 5.17
NCGC - ***	Page 5.19
FXFA - ***	Page 5.21
FCFB - ***	Page 5.23
FDFA - ***	Page 5.25
FQIA - ***	Page 10.15

Instructions for ordering complete cartridge and body assemblies. Page v

Pressure ratings, material specifications. Page 11.02

S4
T18A

Ports 1 & 2	Gage Port	ALUMINUM		DUCTILE IRON	
		Part Number	List Price	Part Number	List Price
.75 NPTF	.25 NPTF	LAD		LAD/S	
1.00 NPTF	.25 NPTF	LAE		LAE/S	
1.25 NPTF	.25 NPTF	LAF		LAF/S	
SAE-12	.25 NPTF	LAL		LAL/S	
SAE-16	.25 NPTF	LAM		LAM/S	
SAE-20	.25 NPTF	LAN		LAN/S	
.75 BSPP	.25 BSPP	LAW		LAW/S	
1.00 BSPP	.25 BSPP	LAX		LAX/S	
1.25 BSPP	.25 BSPP	LAY		LAY/S	

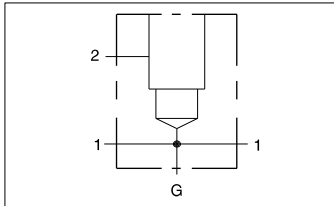

Through port body with gage port.

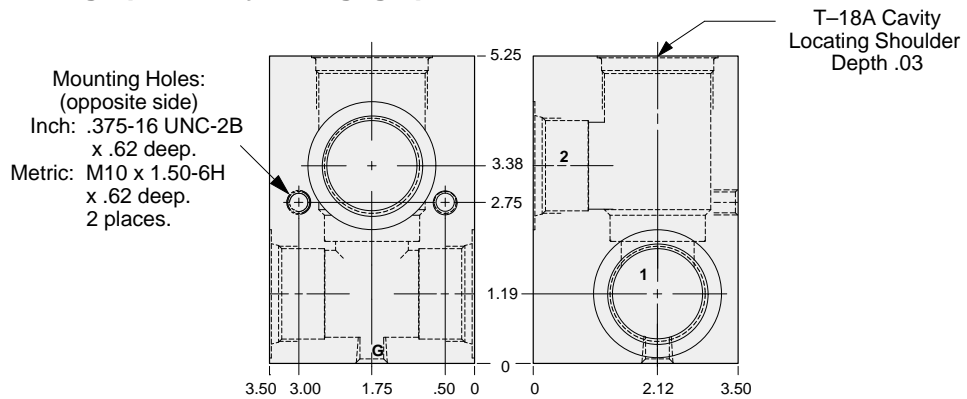

TYPICAL CARTRIDGES USED WITH THIS BODY

RPKC - ***	Page 1.07
RPKE - ***	Page 1.09
RDJA - ***	Page 1.11
RQKB - ***	Page 1.13
RPKD - ***	Page 1.15
NFFC - ***	Page 5.13
CNIC - ***	Page 5.15
NCGB - ***	Page 5.17
NCGC - ***	Page 5.19
FXFA - ***	Page 5.21
FCFB - ***	Page 5.23
FDFA - ***	Page 5.25

Instructions for ordering complete cartridge and body assemblies. Page v

Pressure ratings, material specifications. Page 11.02

Mounting Hole Dimensions	Ports 1 & 2	Gage Port	ALUMINUM		DUCTILE IRON	
			Part Number	List Price	Part Number	List Price
Inch	.75 NPTF	.25 NPTF	LED		LED/S	
Inch	1.00 NPTF	.25 NPTF	LEE		LEE/S	
Inch	1.25 NPTF	.25 NPTF	LEF		LEF/S	
Inch	SAE-12	.25 NPTF	LEL		LEL/S	
Inch	SAE-16	.25 NPTF	LEM		LEM/S	
Inch	SAE-20	.25 NPTF	LEN		LEN/S	
Metric	.75 BSPP	.25 BSPP	LEW		LEW/S	
Metric	1.00 BSPP	.25 BSPP	LEX		LEX/S	
Metric	1.25 BSPP	.25 BSPP	LEY		LEY/S	



LINE MOUNT BODIES



- Aluminum rated to 3000 psi.
- Ductile Iron rated to 5000 psi.

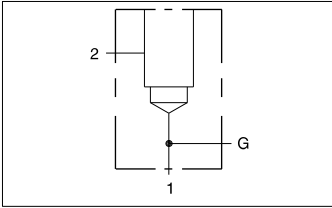

90 degree 1.00" SAE Code 61 flange port body with gage port.

1.00" SAE Code 61
4-Bolt Flange Pattern
2 places.

T-18A Cavity
Locating Shoulder
Depth .06

Mounting Holes:
(opposite side)
Inch: .375-16 UNC-2B
x .62 deep.
Metric: M10 x 1.50-6H
x .62 deep.
2 places.

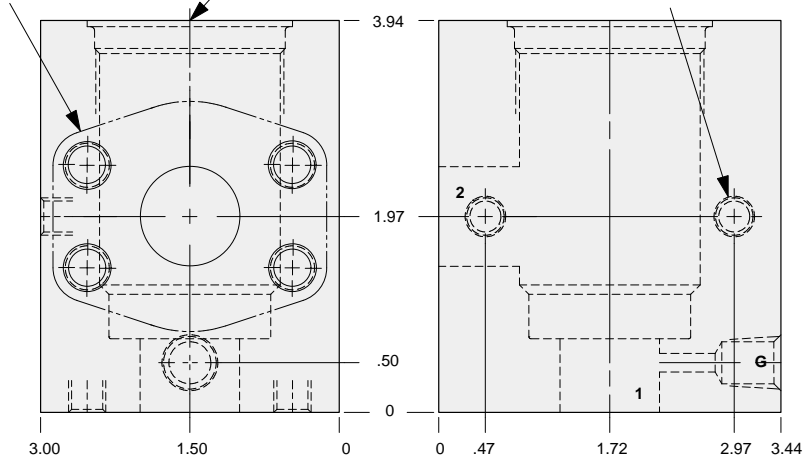

TYPICAL CARTRIDGES USED WITH THIS BODY

RPKC - ***	Page 1.07
RPKE - ***	Page 1.09
RDJA - ***	Page 1.11
RQKB - ***	Page 1.13
RPKD - ***	Page 1.15
CXJA - ***	Page 5.09
CXID - ***	Page 5.11
NFFC - ***	Page 5.13
CNIC - ***	Page 5.15
NCGB - ***	Page 5.17
NCGC - ***	Page 5.19
FXFA - ***	Page 5.21
FCFB - ***	Page 5.23
FDFA - ***	Page 5.25
FQIA - ***	Page 10.15

Instructions for ordering complete cartridge and body assemblies. Page v

Pressure ratings, material specifications. Page 11.02

SAE Specifications Page 11.03

Mounting Hole Dimensions	Gage Port	ALUMINUM		DUCTILE IRON	
		Part Number	List Price	Part Number	List Price
Inch	.25 NPTF	LAP		LAP/S	
Metric	.25 BSPP	LAP/M		LAP/T	

S4
T18A

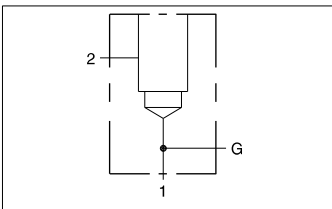

90 degree 1.00" SAE Code 62 flange port body with gage port.

1.00" SAE Code 62
4-Bolt Flange Pattern
2 places.

T-18A Cavity
Locating Shoulder
Depth .06

Mounting Holes:
(opposite side)
Inch: .375-16 UNC-2B
x .62 deep.
Metric: M10 x 1.50-6H
x .62 deep.
2 places.

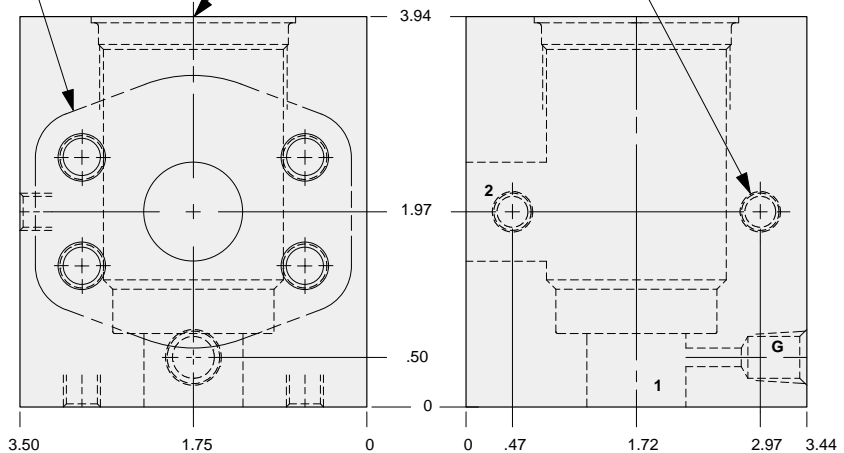

TYPICAL CARTRIDGES USED WITH THIS BODY

RPKC - ***	Page 1.07
RPKE - ***	Page 1.09
RDJA - ***	Page 1.11
RQKB - ***	Page 1.13
RPKD - ***	Page 1.15
CXJA - ***	Page 5.09
CXID - ***	Page 5.11
NFFC - ***	Page 5.13
CNIC - ***	Page 5.15
NCGB - ***	Page 5.17
NCGC - ***	Page 5.19
FXFA - ***	Page 5.21
FCFB - ***	Page 5.23
FDFA - ***	Page 5.25
FQIA - ***	Page 10.15

Instructions for ordering complete cartridge and body assemblies. Page v

Pressure ratings, material specifications. Page 11.02

SAE Specifications Page 11.03

Mounting Hole Dimensions	Gage Port	ALUMINUM		DUCTILE IRON	
		Part Number	List Price	Part Number	List Price
Inch	.25 NPTF	LA4		LA4/S	
Metric	.25 BSPP	LA4/M		LA4/T	



LINE MOUNT BODIES



- Aluminum rated to 3000 psi.
- Ductile Iron rated to 5000 psi.

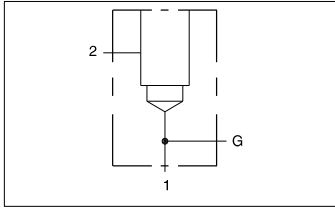

90 degree 1.25" SAE Code 61 flange port body with gage port.

1.25" SAE Code 61
4-Bolt Flange Pattern
2 places.

T-18A Cavity
Locating Shoulder
Depth .09

Mounting Holes:
(opposite side)
Inch: .375-16 UNC-2B
x .75 deep.
Metric: M10 x 1.50-6H
x .75 deep.
2 places.

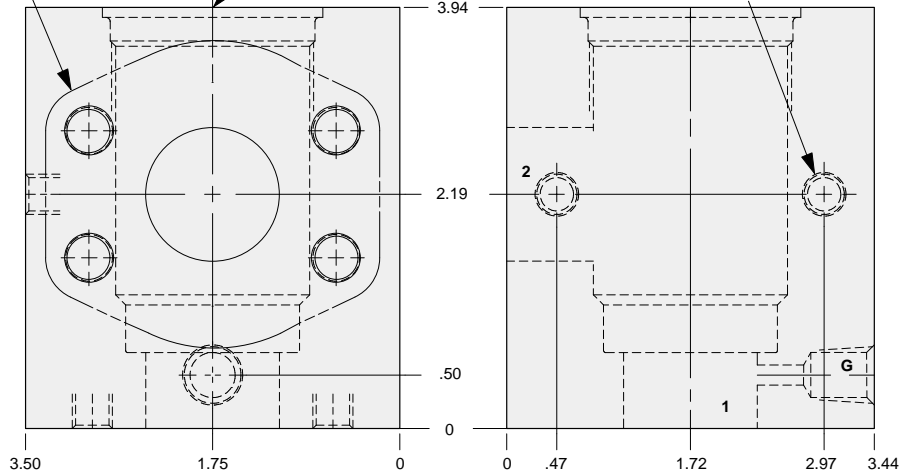

TYPICAL CARTRIDGES USED WITH THIS BODY

RPKC - ***	Page 1.07
RPKE - ***	Page 1.09
RDJA - ***	Page 1.11
RQKB - ***	Page 1.13
RPKD - ***	Page 1.15
CXJA - ***	Page 5.09
CXID - ***	Page 5.11
NFFC - ***	Page 5.13
CNIC - ***	Page 5.15
NCGB - ***	Page 5.17
NCGC - ***	Page 5.19
FXFA - ***	Page 5.21
FCFB - ***	Page 5.23
FDFA - ***	Page 5.25
FQIA - ***	Page 10.15

Instructions for ordering complete cartridge and body assemblies. Page v

Pressure ratings, material specifications. Page 11.02

SAE Specifications Page 11.03

Mounting Hole Dimensions	Gage Port	ALUMINUM		DUCTILE IRON	
		Part Number	List Price	Part Number	List Price
Inch	.25 NPTF	LAQ		LAQ/S	
Metric	.25 BSPP	LAQ/M		LAQ/T	

S4
T18A

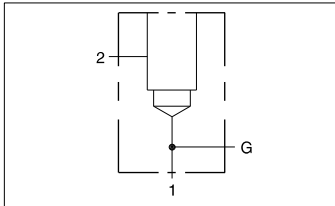

90 degree 1.25" SAE Code 62 flange port body with gage port.

1.25" SAE Code 62
4-Bolt Flange Pattern
2 places.

T-18A Cavity
Locating Shoulder
Depth .06

Mounting Holes:
(opposite side)
Inch: .375-16 UNC-2B
x .75 deep.
Metric: M10 x 1.50-6H
x .75 deep.
2 places.

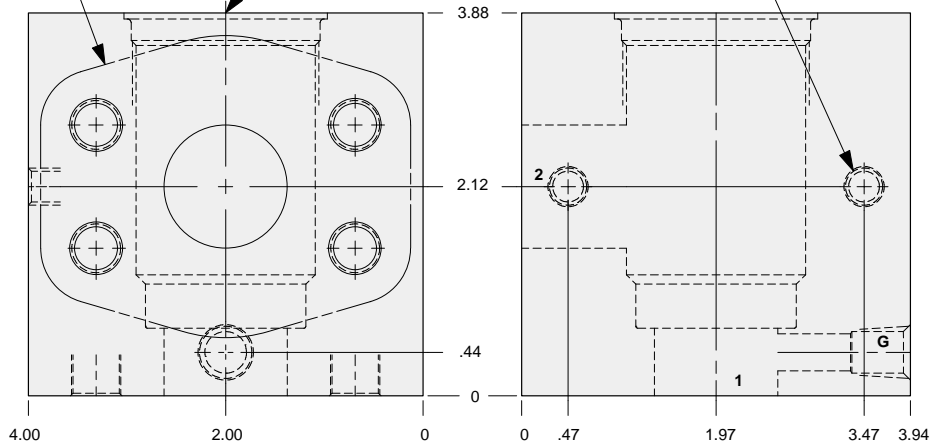

TYPICAL CARTRIDGES USED WITH THIS BODY

RPKC - ***	Page 1.07
RPKE - ***	Page 1.09
RDJA - ***	Page 1.11
RQKB - ***	Page 1.13
RPKD - ***	Page 1.15
CXJA - ***	Page 5.09
CXID - ***	Page 5.11
NFFC - ***	Page 5.13
CNIC - ***	Page 5.15
NCGB - ***	Page 5.17
NCGC - ***	Page 5.19
FXFA - ***	Page 5.21
FCFB - ***	Page 5.23
FDFA - ***	Page 5.25
FQIA - ***	Page 10.15

Instructions for ordering complete cartridge and body assemblies. Page v

Pressure ratings, material specifications. Page 11.02

SAE Specifications Page 11.03

Mounting Hole Dimensions	Gage Port	ALUMINUM		DUCTILE IRON	
		Part Number	List Price	Part Number	List Price
Inch	.25 NPTF	LA5		LA5/S	
Metric	.25 BSPP	LA5/M		LA5/T	



LINE MOUNT BODIES



- Aluminum rated to 3000 psi.
- Ductile Iron rated to 5000 psi.

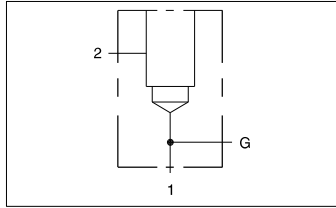

90 degree 1.50" SAE Code 61 flange port body with gage port.

1.50" SAE Code 61
4-Bolt Flange Pattern
2 places.

T-18A Cavity
Locating Shoulder
Depth .09

Mounting Holes:
(opposite side)
Inch: .375-16 UNC-2B
x .75 deep.
Metric: M10 x 1.50-6H
x .75 deep.
2 places.

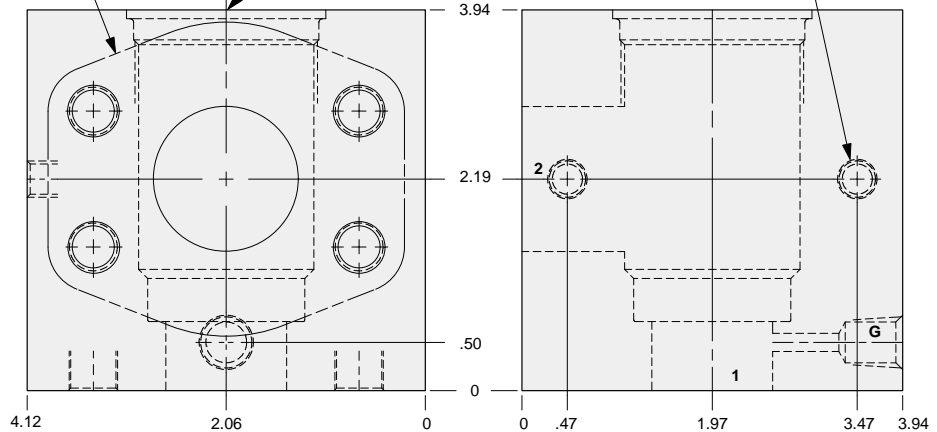

S4
T18A

TYPICAL CARTRIDGES USED WITH THIS BODY

RPKC - ***	Page 1.07
RPKE - ***	Page 1.09
RDJA - ***	Page 1.11
RQKB - ***	Page 1.13
RPKD - ***	Page 1.15
CXJA - ***	Page 5.09
CXID - ***	Page 5.11
NFFC - ***	Page 5.13
CNIC - ***	Page 5.15
NCGB - ***	Page 5.17
NCGC - ***	Page 5.19
FXFA - ***	Page 5.21
FCFB - ***	Page 5.23
FDFA - ***	Page 5.25
FQIA - ***	Page 10.15

Instructions for ordering complete cartridge and body assemblies. Page v

Pressure ratings, material specifications. Page 11.02

SAE Specifications Page 11.03

Mounting Hole Dimensions	Gage Port	ALUMINUM		DUCTILE IRON	
		Part Number	List Price	Part Number	List Price
Inch	.25 NPTF	LAR		LAR/S	
Metric	.25 BSPP	LAR/M		LAR/T	

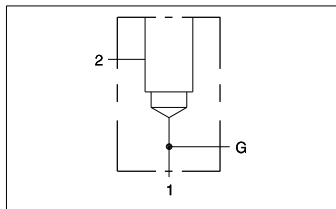

90 degree 1.50" SAE Code 62 flange port body with gage port.

1.50" SAE Code 62
4-Bolt Flange Pattern
2 places.

T-18A Cavity
Locating Shoulder
Depth .22

Mounting Holes:
(opposite side)
Inch: .500-13 UNC
x .75 deep.
Metric: M12 x 1.75-6H
x .75 deep.
2 places.

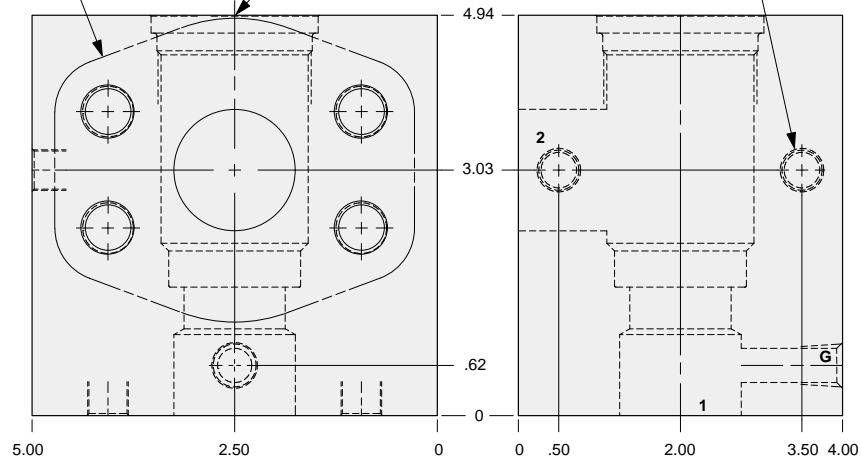

TYPICAL CARTRIDGES USED WITH THIS BODY

RPKC - ***	Page 1.07
RPKE - ***	Page 1.09
RDJA - ***	Page 1.11
RQKB - ***	Page 1.13
RPKD - ***	Page 1.15
CXJA - ***	Page 5.09
CXID - ***	Page 5.11
NFFC - ***	Page 5.13
CNIC - ***	Page 5.15
NCGB - ***	Page 5.17
NCGC - ***	Page 5.19
FXFA - ***	Page 5.21
FCFB - ***	Page 5.23
FDFA - ***	Page 5.25
FQIA - ***	Page 10.15

Instructions for ordering complete cartridge and body assemblies. Page v

Pressure ratings, material specifications. Page 11.02

SAE Specifications Page 11.03

Mounting Hole Dimensions	Gage Port	ALUMINUM		DUCTILE IRON	
		Part Number	List Price	Part Number	List Price
Inch	.25 NPTF	LA6		LA6/S	
Metric	.25 BSPP	LA6/M		LA6/T	



LINE MOUNT BODIES

- Aluminum rated to 3000 psi.
- Ductile Iron rated to 5000 psi.



90 degree 2.00" SAE Code 61 flange port body with gage port.

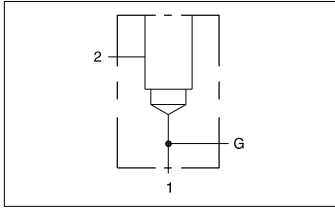

2.00" SAE Code 61
4-Bolt Flange Pattern
2 places.

T-18A Cavity
Locating Shoulder
Depth .09

Mounting Holes:
(opposite side)
Inch: .375-16 UNC-2B
x .75 deep.
Metric: M10 x 1.50-6H
x .75 deep.
2 places.

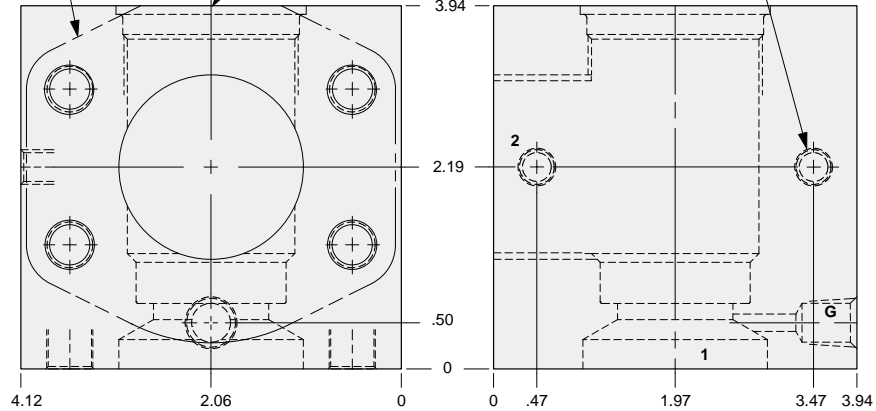

Mounting Hole Dimensions	Gage Port	ALUMINUM		DUCTILE IRON	
		Part Number	List Price	Part Number	List Price
Inch	.25 NPTF	LAS		LAS/S	
Metric	.25 BSPP	LAS/M		LAS/T	

TYPICAL CARTRIDGES USED WITH THIS BODY

RPKC - ***	Page 1.07
RPKE - ***	Page 1.09
RDJA - ***	Page 1.11
RQKB - ***	Page 1.13
RPKD - ***	Page 1.15
CXJA - ***	Page 5.09
CXID - ***	Page 5.11
NFFC - ***	Page 5.13
CNIC - ***	Page 5.15
NCGB - ***	Page 5.17
NCGC - ***	Page 5.19
FXFA - ***	Page 5.21
FCFB - ***	Page 5.23
FDFA - ***	Page 5.25
FQIA - ***	Page 10.15

Instructions for ordering complete cartridge and body assemblies. Page v

Pressure ratings, material specifications. Page 11.02

SAE Specifications Page 11.03

S4
T18A

90 degree 2.00" SAE Code 62 flange port body with gage port.

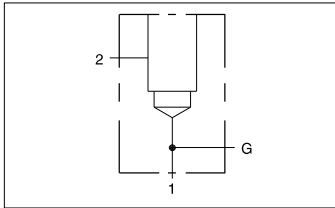

2.00" SAE Code 62
4-Bolt Flange Pattern
2 places.

T-18A Cavity
Locating Shoulder
Depth .59

Mounting Holes:
(opposite side)
Inch: .375-16 UNC-2B
x .62 deep.
Metric: M10 x 1.50-6H
x .62 deep.
2 places.

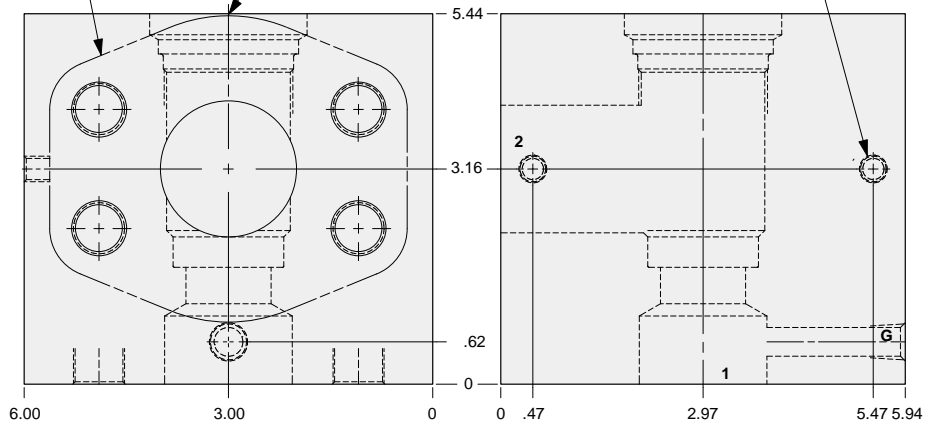

Mounting Hole Dimensions	Gage Port	ALUMINUM		DUCTILE IRON	
		Part Number	List Price	Part Number	List Price
Inch	.25 NPTF	LA8		LA8/S	
Metric	.25 BSPP	LA8/M		LA8/T	

TYPICAL CARTRIDGES USED WITH THIS BODY

RPKC - ***	Page 1.07
RPKE - ***	Page 1.09
RDJA - ***	Page 1.11
RQKB - ***	Page 1.13
RPKD - ***	Page 1.15
CXJA - ***	Page 5.09
CXID - ***	Page 5.11
NFFC - ***	Page 5.13
CNIC - ***	Page 5.15
NCGB - ***	Page 5.17
NCGC - ***	Page 5.19
FXFA - ***	Page 5.21
FCFB - ***	Page 5.23
FDFA - ***	Page 5.25
FQIA - ***	Page 10.15

Instructions for ordering complete cartridge and body assemblies. Page v

Pressure ratings, material specifications. Page 11.02

SAE Specifications Page 11.03



LINE MOUNT BODIES



- Aluminum rated to 3000 psi.
- Ductile Iron rated to 5000 psi.

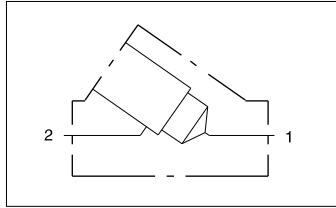

Inline 1.50" SAE Code 61 flange port body.

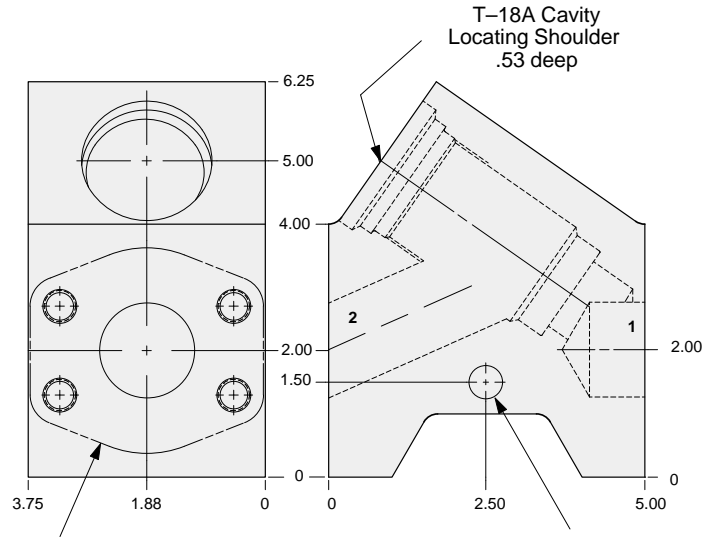

1.50" SAE Code 61
4-Bolt Flange Pattern
2 places.

Mounting Hole:
Inch: .53 diameter through hole.
Metric: .50 diameter through hole.

S4
T18A

TYPICAL CARTRIDGES USED WITH THIS BODY

RPKC - ***	Page 1.07
RPKE - ***	Page 1.09
RDJA - ***	Page 1.11
RQKB - ***	Page 1.13
RPKD - ***	Page 1.15
CXJA - ***	Page 5.09
CXID - ***	Page 5.11
NFFC - ***	Page 5.13
CNIC - ***	Page 5.15
NCGB - ***	Page 5.17
NCGC - ***	Page 5.19
FXFA - ***	Page 5.21
FCFB - ***	Page 5.23
FDFA - ***	Page 5.25
FQIA - ***	Page 10.15

Instructions for ordering complete cartridge and body assemblies. Page v

Pressure ratings, material specifications. Page 11.02

SAE Specifications Page 11.03

Mounting Hole Dimensions	ALUMINUM		DUCTILE IRON	
	Part Number	List Price	Part Number	List Price
Inch	ZLS		ZLS/S	
Metric	ZLS/M		ZLS/T	

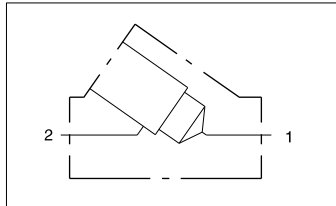

Inline 2.00" SAE Code 61 flange port body.

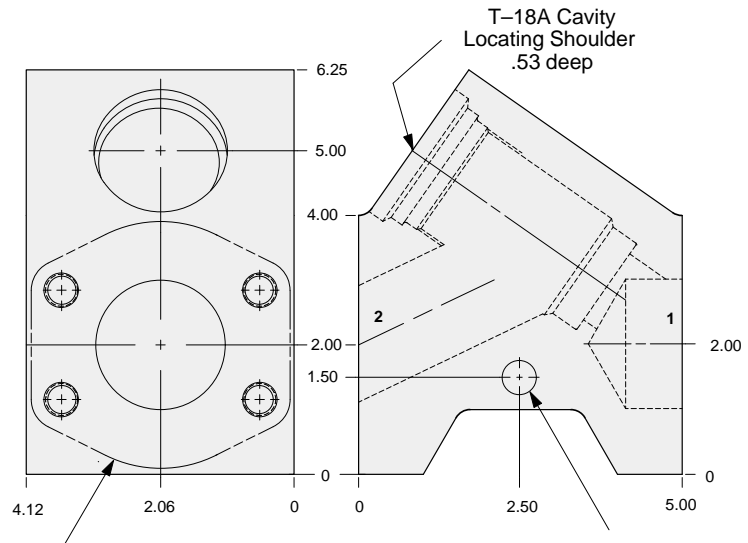

2.00" SAE Code 61
4-Bolt Flange Pattern
2 places.

Mounting Hole:
Inch: .53 diameter through hole.
Metric: .50 diameter through hole.

TYPICAL CARTRIDGES USED WITH THIS BODY

RPKC - ***	Page 1.07
RPKE - ***	Page 1.09
RDJA - ***	Page 1.11
RQKB - ***	Page 1.13
RPKD - ***	Page 1.15
CXJA - ***	Page 5.09
CXID - ***	Page 5.11
NFFC - ***	Page 5.13
CNIC - ***	Page 5.15
NCGB - ***	Page 5.17
NCGC - ***	Page 5.19
FXFA - ***	Page 5.21
FCFB - ***	Page 5.23
FDFA - ***	Page 5.25
FQIA - ***	Page 10.15

Instructions for ordering complete cartridge and body assemblies. Page v

Pressure ratings, material specifications. Page 11.02

SAE Specifications Page 11.03

Mounting Hole Dimensions	ALUMINUM		DUCTILE IRON	
	Part Number	List Price	Part Number	List Price
Inch	ZLR		ZLR/S	
Metric	ZLR/M		ZLR/T	



LINE MOUNT BODIES



- Aluminum rated to 3000 psi.
- Ductile Iron rated to 5000 psi.

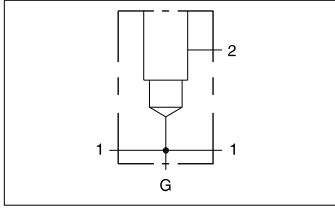

Through port 1.00" SAE Code 61 flange port body with gage port.

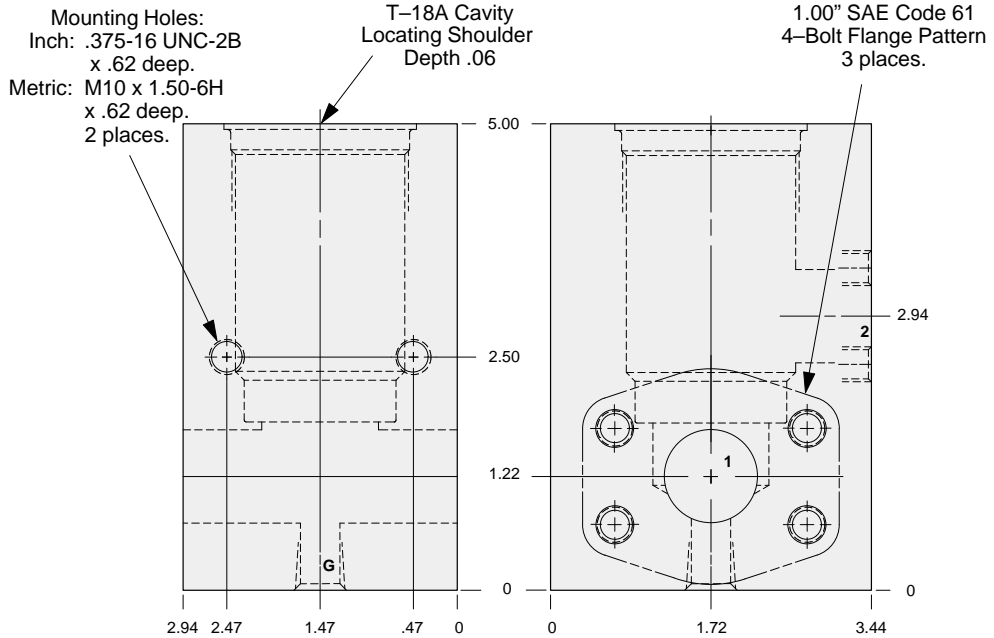

TYPICAL CARTRIDGES USED WITH THIS BODY

RPKC - ***	Page 1.07
RPKE - ***	Page 1.09
RDJA - ***	Page 1.11
RQKB - ***	Page 1.13
RPKD - ***	Page 1.15
NFFC - ***	Page 5.13
CNIC - ***	Page 5.15
NCGB - ***	Page 5.17
NCGC - ***	Page 5.19
FXFA - ***	Page 5.21
FCFB - ***	Page 5.23
FDFA - ***	Page 5.25

S4
T18A

Instructions for ordering complete cartridge and body assemblies. Page v

Pressure ratings, material specifications.. Page 11.02

SAE Specifications Page 11.03

Mounting Hole Dimensions	Gage Port	ALUMINUM		DUCTILE IRON	
		Part Number	List Price	Part Number	List Price
Inch	.25 NPTF	LEP		LEP/S	
Metric	.25 BSPP	LEP/M		LEP/T	

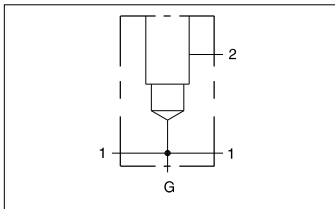

Through port 1.00" SAE Code 62 flange port body with gage port.

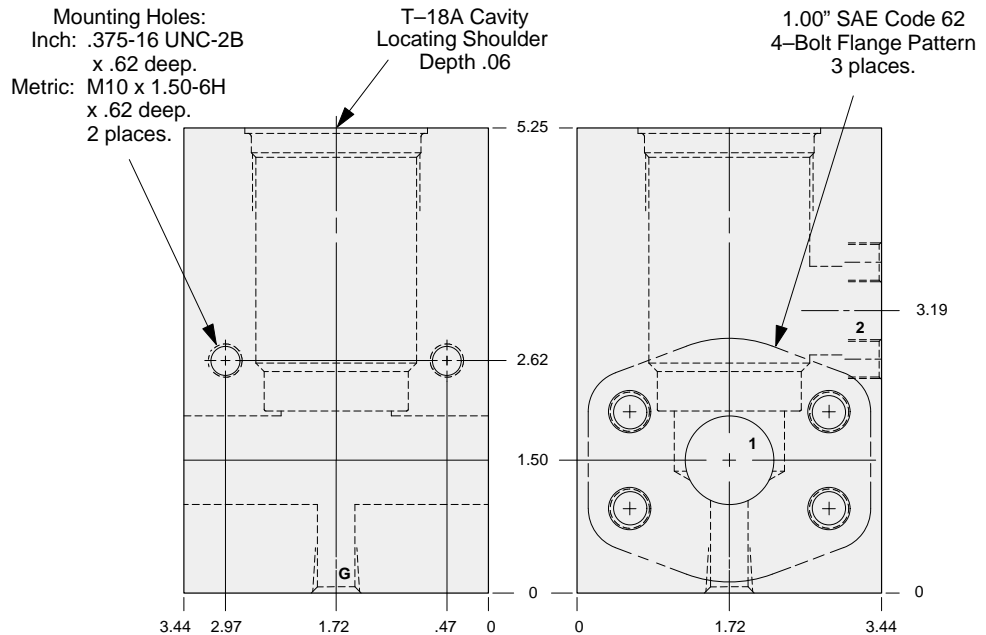

TYPICAL CARTRIDGES USED WITH THIS BODY

RPKC - ***	Page 1.07
RPKE - ***	Page 1.09
RDJA - ***	Page 1.11
RQKB - ***	Page 1.13
RPKD - ***	Page 1.15
NFFC - ***	Page 5.13
CNIC - ***	Page 5.15
NCGB - ***	Page 5.17
NCGC - ***	Page 5.19
FXFA - ***	Page 5.21
FCFB - ***	Page 5.23
FDFA - ***	Page 5.25

Instructions for ordering complete cartridge and body assemblies. Page v

Pressure ratings, material specifications. Page 11.02

SAE Specifications Page 11.03

Mounting Hole Dimensions	Gage Port	ALUMINUM		DUCTILE IRON	
		Part Number	List Price	Part Number	List Price
Inch	.25 NPTF	LE4		LE4/S	
Metric	.25 BSPP	LE4/M		LE4/T	



LINE MOUNT BODIES



- Aluminum rated to 3000 psi.
- Ductile Iron rated to 5000 psi.

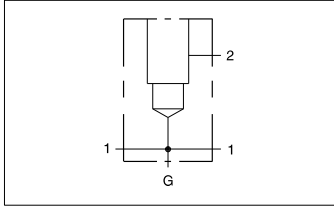

Through port 1.25" SAE Code 61 flange port body with gage port.

Mounting Holes:
 Inch: .375-16 UNC-2B x .62 deep.
 Metric: M10 x 1.50-6H x .62 deep. 2 places.

T-18A Cavity Locating Shoulder Depth .06

1.25" SAE Code 61 4-Bolt Flange Pattern 3 places.

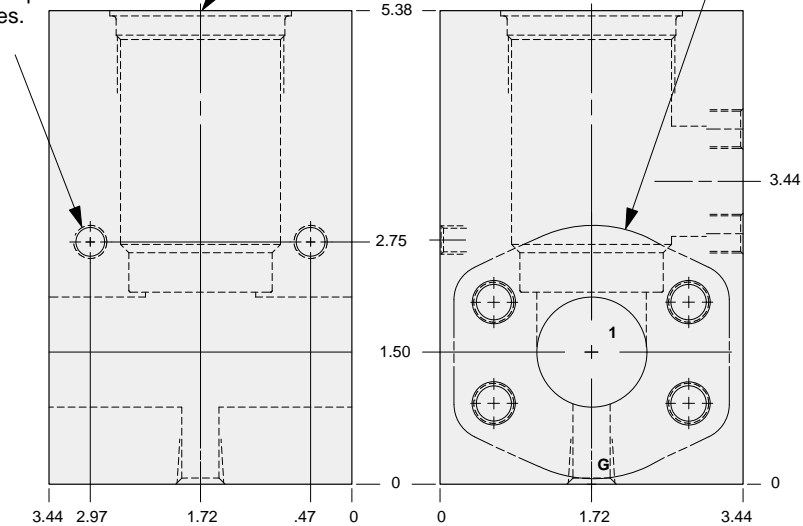

Mounting Hole Dimensions	Gage Port	ALUMINUM		DUCTILE IRON	
		Part Number	List Price	Part Number	List Price
Inch	.25 NPTF	LEQ		LEQ/S	
Metric	.25 BSPP	LEQ/M		LEQ/T	

TYPICAL CARTRIDGES USED WITH THIS BODY

RPKC - ***	Page 1.07
RPKE - ***	Page 1.09
RDJA - ***	Page 1.11
RQKB - ***	Page 1.13
RPKD - ***	Page 1.15
NFFC - ***	Page 5.13
CNIC - ***	Page 5.15
NCGB - ***	Page 5.17
NCGC - ***	Page 5.19
FXFA - ***	Page 5.21
FCFB - ***	Page 5.23
FDFA - ***	Page 5.25

Instructions for ordering complete cartridge and body assemblies. Page v

Pressure ratings, material specifications. Page 11.02

SAE Specifications Page 11.03

S4
T18A

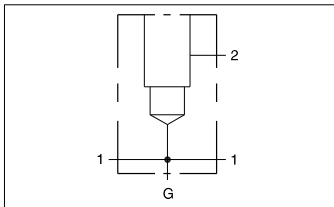

Through port 1.25" SAE Code 62 flange port body with gage port.

Mounting Holes:
 Inch: .375-16 UNC-2B x .62 deep.
 Metric: M10 x 1.50-6H x .62 deep. 2 places.

T-18A Cavity Locating Shoulder Depth .06

1.25" SAE Code 62 4-Bolt Flange Pattern 3 places.

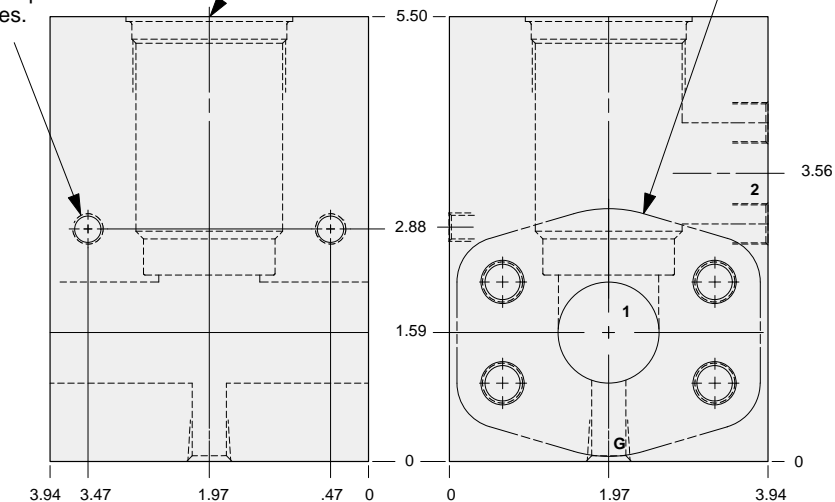

Mounting Hole Dimensions	Gage Port	ALUMINUM		DUCTILE IRON	
		Part Number	List Price	Part Number	List Price
Inch	.25 NPTF	LE5		LE5/S	
Metric	.25 BSPP	LE5/M		LE5/T	

TYPICAL CARTRIDGES USED WITH THIS BODY

RPKC - ***	Page 1.07
RPKE - ***	Page 1.09
RDJA - ***	Page 1.11
RQKB - ***	Page 1.13
RPKD - ***	Page 1.15
NFFC - ***	Page 5.13
CNIC - ***	Page 5.15
NCGB - ***	Page 5.17
NCGC - ***	Page 5.19
FXFA - ***	Page 5.21
FCFB - ***	Page 5.23
FDFA - ***	Page 5.25

Instructions for ordering complete cartridge and body assemblies. Page v

Pressure ratings, material specifications. Page 11.02

SAE Specifications Page 11.03



LINE MOUNT BODIES



- Aluminum rated to 3000 psi.
- Ductile Iron rated to 5000 psi.

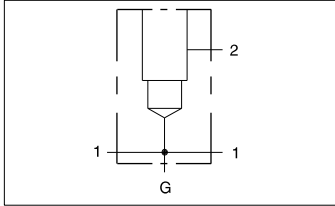

Through port 1.50" SAE Code 61 flange port body with gage port.

Mounting Holes:
Inch: .375-16 UNC-2B
x .62 deep.
Metric: M10 x 1.50-6H
x .62 deep.
2 places.

T-18A Cavity
Locating Shoulder
Depth .03

1.50" SAE Code 61
4-Bolt Flange Pattern
3 places.

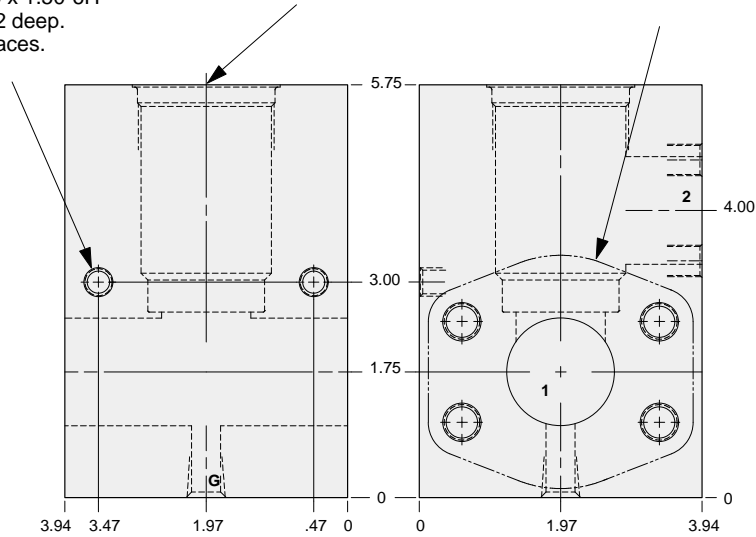

TYPICAL CARTRIDGES USED WITH THIS BODY

RPKC - ***	Page 1.07
RPKE - ***	Page 1.09
RDJA - ***	Page 1.11
RQKB - ***	Page 1.13
RPKD - ***	Page 1.15
NFFC - ***	Page 5.13
CNIC - ***	Page 5.15
NCGB - ***	Page 5.17
NCGC - ***	Page 5.19
FXFA - ***	Page 5.21
FCFB - ***	Page 5.23
FDFA - ***	Page 5.25

S4
T18A

Instructions for ordering complete cartridge and body assemblies. Page v

Pressure ratings, material specifications. Page 11.02

SAE Specifications Page 11.03

Mounting Hole Dimensions	Gage Port	ALUMINUM		DUCTILE IRON	
		Part Number	List Price	Part Number	List Price
Inch	.25 NPTF	LER		LER/S	
Metric	.25 BSPP	LER/M		LER/T	

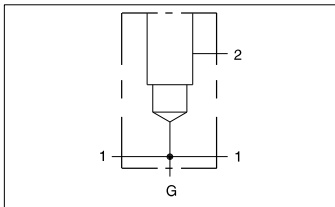

Through port 1.50" SAE Code 62 flange port body with gage port.

Mounting Holes:
Inch: .500-13 UNC-2B
x .75 deep.
Metric: M12 x 1.75-6H
x .75 deep.
2 places.

T-18A Cavity
Locating Shoulder
Depth .03

1.50" SAE Code 62
4-Bolt Flange Pattern
3 places.

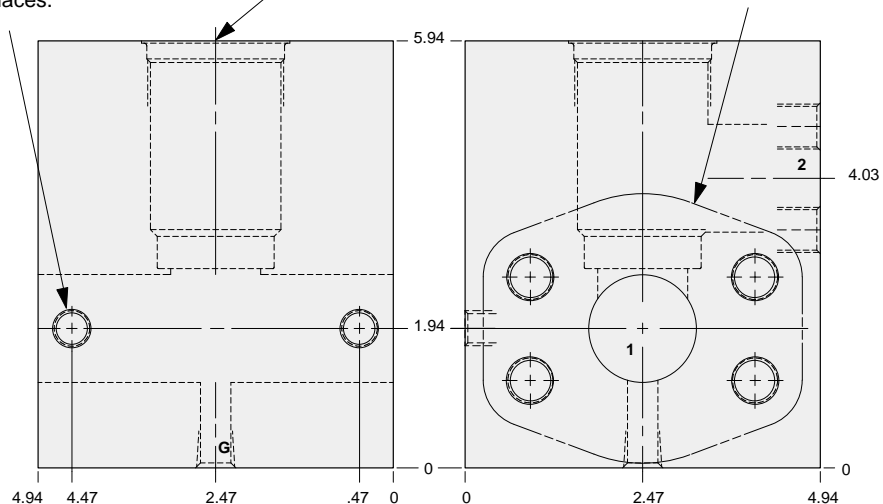

TYPICAL CARTRIDGES USED WITH THIS BODY

RPKC - ***	Page 1.07
RPKE - ***	Page 1.09
RDJA - ***	Page 1.11
RQKB - ***	Page 1.13
RPKD - ***	Page 1.15
NFFC - ***	Page 5.13
CNIC - ***	Page 5.15
NCGB - ***	Page 5.17
NCGC - ***	Page 5.19
FXFA - ***	Page 5.21
FCFB - ***	Page 5.23
FDFA - ***	Page 5.25

Instructions for ordering complete cartridge and body assemblies. Page v

Pressure ratings, material specifications. Page 11.02

SAE Specifications Page 11.03

Mounting Hole Dimensions	Gage Port	ALUMINUM		DUCTILE IRON	
		Part Number	List Price	Part Number	List Price
Inch	.25 NPTF	LE6		LE6/S	
Metric	.25 BSPP	LE6/M		LE6/T	



LINE MOUNT BODIES



- Aluminum rated to 3000 psi.
- Ductile Iron rated to 5000 psi.

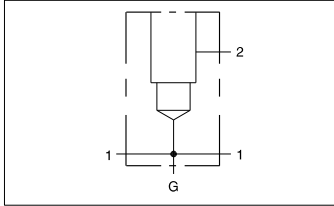

Through port 2.00" SAE Code 61 flange port body with gage port.

Mounting Holes:
Inch: .375-16 UNC-2B
x .62 deep.
Metric: M10 x 1.50-6H
x .62 deep.
2 places.

T-18A Cavity
Locating Shoulder
Depth .31

2.00" SAE Code 61
4-Bolt Flange Pattern
3 places.

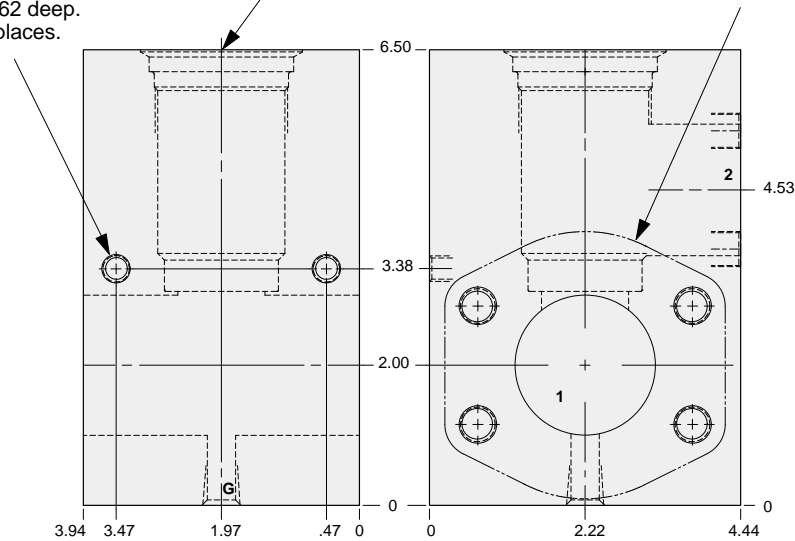

TYPICAL CARTRIDGES USED WITH THIS BODY

RPKC - ***	Page 1.07
RPKE - ***	Page 1.09
RDJA - ***	Page 1.11
RQKB - ***	Page 1.13
RPKD - ***	Page 1.15
NFFC - ***	Page 5.13
CNIC - ***	Page 5.15
NCGB - ***	Page 5.17
NCGC - ***	Page 5.19
FXFA - ***	Page 5.21
FCFB - ***	Page 5.23
FDFA - ***	Page 5.25

Instructions for ordering complete cartridge and body assemblies. Page v

Pressure ratings, material specifications. Page 11.02

SAE Specifications Page 11.03

Mounting Hole Dimensions	Gage Port	ALUMINUM		DUCTILE IRON	
		Part Number	List Price	Part Number	List Price
Inch	.25 NPTF	LES		LES/S	
Metric	.25 BSPP	LES/M		LES/T	

S4
T18A

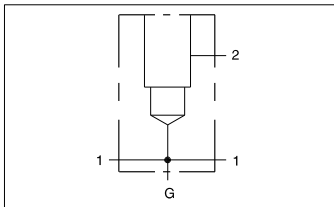

Through port 2.00" SAE Code 62 flange port body with gage port.

Mounting Holes:
Inch: .500-13 UNC-2B
x .75 deep.
Metric: M12 x 1.75-6H
x .75 deep.
2 places.

T-18A Cavity
Locating Shoulder
Depth .59

2.00" SAE Code 62
4-Bolt Flange Pattern
3 places.

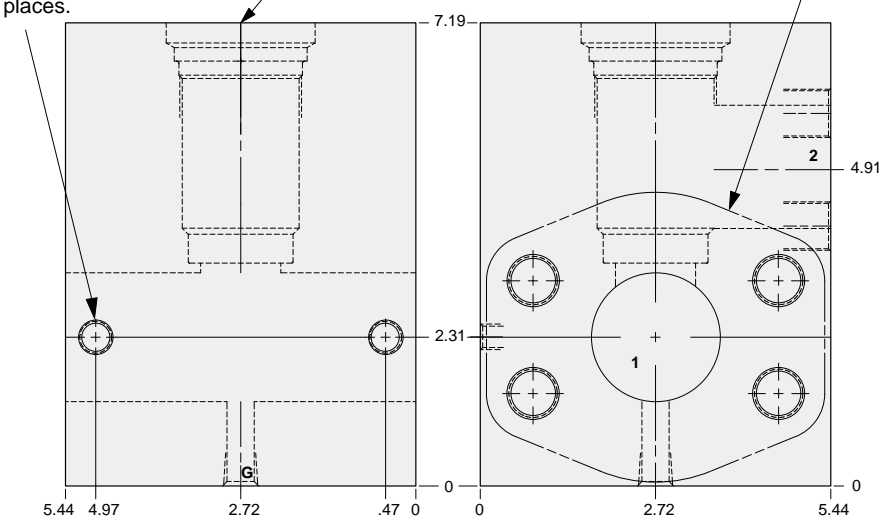

TYPICAL CARTRIDGES USED WITH THIS BODY

RPKC - ***	Page 1.07
RPKE - ***	Page 1.09
RDJA - ***	Page 1.11
RQKB - ***	Page 1.13
RPKD - ***	Page 1.15
NFFC - ***	Page 5.13
CNIC - ***	Page 5.15
NCGB - ***	Page 5.17
NCGC - ***	Page 5.19
FXFA - ***	Page 5.21
FCFB - ***	Page 5.23
FDFA - ***	Page 5.25

Instructions for ordering complete cartridge and body assemblies. Page v

Pressure ratings, material specifications. Page 11.02

SAE Specifications Page 11.03

Mounting Hole Dimensions	Gage Port	ALUMINUM		DUCTILE IRON	
		Part Number	List Price	Part Number	List Price
Inch	.25 NPTF	LE8		LE8/S	
Metric	.25 BSPP	LE8/M		LE8/T	



LINE MOUNT BODIES



- Aluminum rated to 3000 psi.
- Ductile Iron rated to 5000 psi.

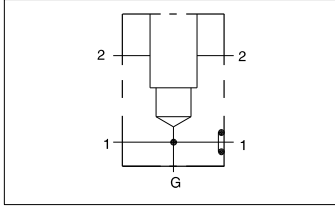

Sandwich mount through flange port 1.00" SAE Code 62 body with gage port.

T-18A Cavity
Locating Shoulder
Depth .06

1.00" SAE Code 62
4-Bolt Flange Pattern
3 places.
Port 1 through hole
Port 2 tapped hole

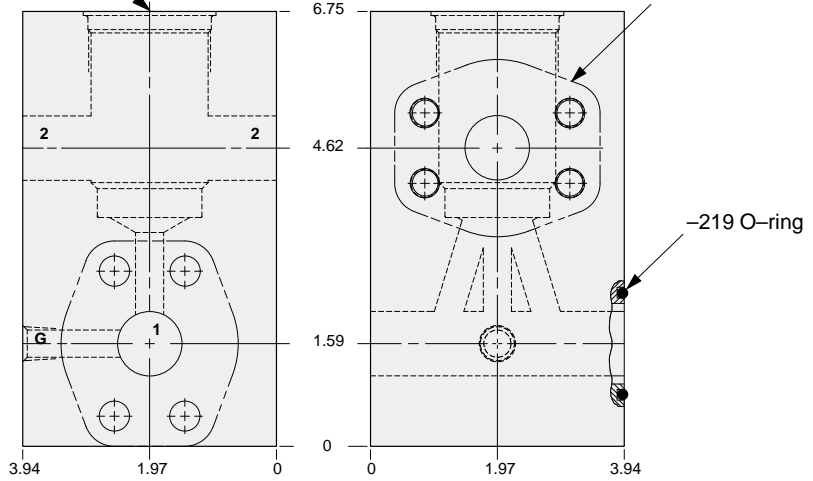

TYPICAL CARTRIDGES USED WITH THIS BODY

- | | |
|------------|-----------|
| RPKC - *** | Page 1.07 |
| RPKE - *** | Page 1.09 |
| RDJA - *** | Page 1.11 |
| RQKB - *** | Page 1.13 |
| RPKD - *** | Page 1.15 |

Cartridge seal type determines O-ring type.

Instructions for ordering complete cartridge and body assemblies. Page v

S4
T18A

Pressure ratings, material specifications. Page 11.02

SAE Specifications Page 11.03

Mounting Hole Dimensions	Gage Port	ALUMINUM		DUCTILE IRON	
		Part Number	List Price	Part Number	List Price
Inch	.25 NPTF	WJM		WJM/S	
Metric	.25 BSPP	WJM/M		WJM/T	



LINE MOUNT BODIES



- Aluminum rated to 3000 psi.
- Ductile Iron rated to 5000 psi.

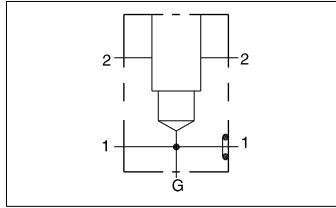

Sandwich mount through flange port 2.00" SAE Code 61 body with gage port.

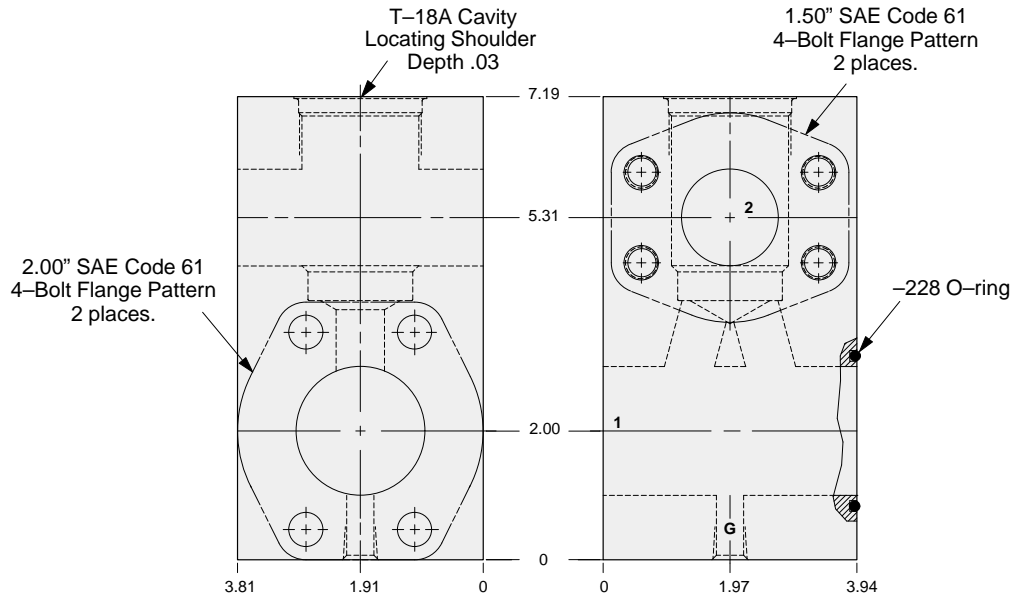

S4
T18A

TYPICAL CARTRIDGES USED WITH THIS BODY

- | | |
|------------|-----------|
| RPKC - *** | Page 1.07 |
| RPKE - *** | Page 1.09 |
| RDJA - *** | Page 1.11 |
| RQKB - *** | Page 1.13 |
| RPKD - *** | Page 1.15 |

Cartridge seal type determines O-ring type.

Instructions for ordering complete cartridge and body assemblies. Page v

Pressure ratings, material specifications. Page 11.02

SAE Specifications Page 11.03

Mounting Hole Dimensions	Port 2 SAE Code 61	Gage Port	ALUMINUM		DUCTILE IRON	
			Part Number	List Price	Part Number	List Price
Inch	1.50"	.25 NPTF	ZBF		ZBF/S	
Metric	1.50"	.25 BSPP	ZBF/M		ZBF/T	

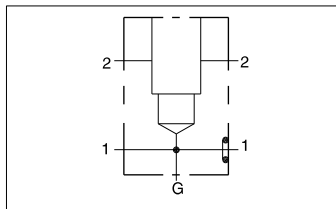

Sandwich mount through flange port 2.00" SAE Code 62 body with gage port.

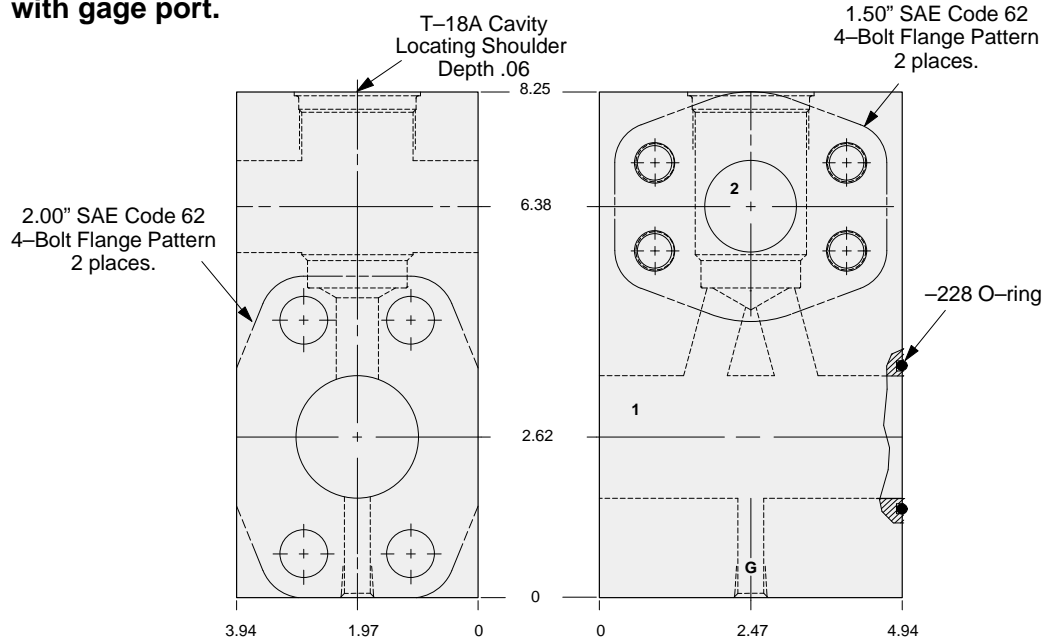

TYPICAL CARTRIDGES USED WITH THIS BODY

- | | |
|------------|-----------|
| RPKC - *** | Page 1.07 |
| RPKE - *** | Page 1.09 |
| RDJA - *** | Page 1.11 |
| RQKB - *** | Page 1.13 |
| RPKD - *** | Page 1.15 |

Cartridge seal type determines O-ring type.

Instructions for ordering complete cartridge and body assemblies. Page v

Pressure ratings, material specifications. Page 11.02

SAE Specifications Page 11.03

Mounting Hole Dimensions	Port 2 SAE Code 62	Gage Port	ALUMINUM		DUCTILE IRON	
			Part Number	List Price	Part Number	List Price
Inch	1.50"	.25 NPTF	ZBH		ZBH/S	
Metric	1.50"	.25 BSPP	ZBH/M		ZBH/T	



LINE MOUNT BODIES



- Aluminum rated to 3000 psi.
- Ductile Iron rated to 5000 psi.

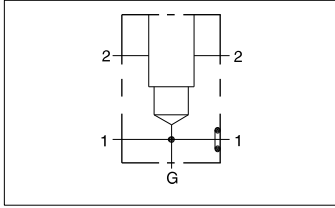

Sandwich mount through flange port 2.00" SAE Code 61 body with gage port.

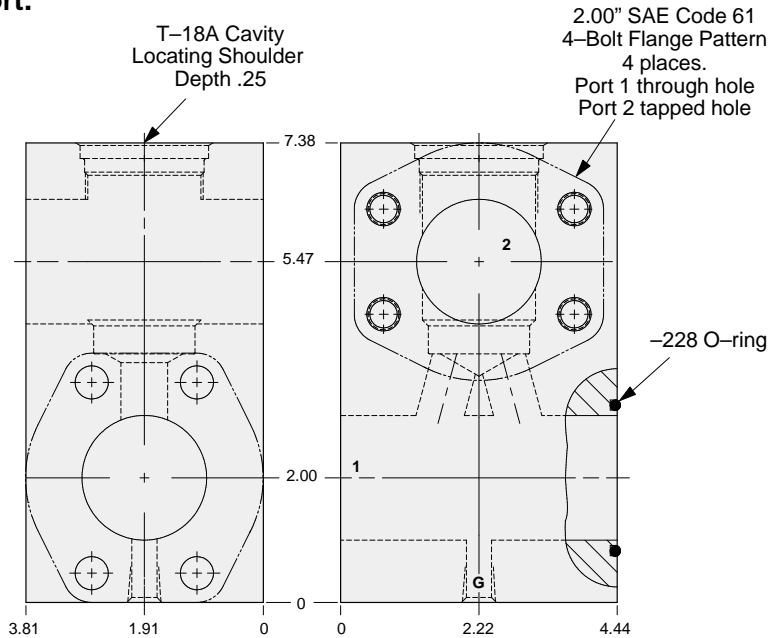

TYPICAL CARTRIDGES USED WITH THIS BODY

- RPKC - *** Page 1.07
- RPKE - *** Page 1.09
- RDJA - *** Page 1.11
- RQKB - *** Page 1.13
- RPKD - *** Page 1.15

Cartridge seal type determines O-ring type.

Instructions for ordering complete cartridge and body assemblies. Page v

S4
T18A

Pressure ratings, material specifications. Page 11.02

SAE Specifications Page 11.03

Mounting Hole Dimensions	Gage Port	ALUMINUM		DUCTILE IRON	
		Part Number	List Price	Part Number	List Price
Inch	.25 NPTF	ZBE		ZBE/S	
Metric	.25 BSPP	ZBE/M		ZBE/T	

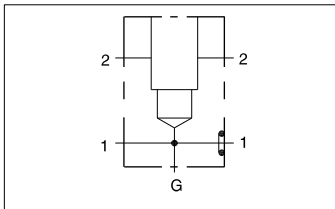

Sandwich mount through flange port 2.00" SAE Code 62 body with gage port.

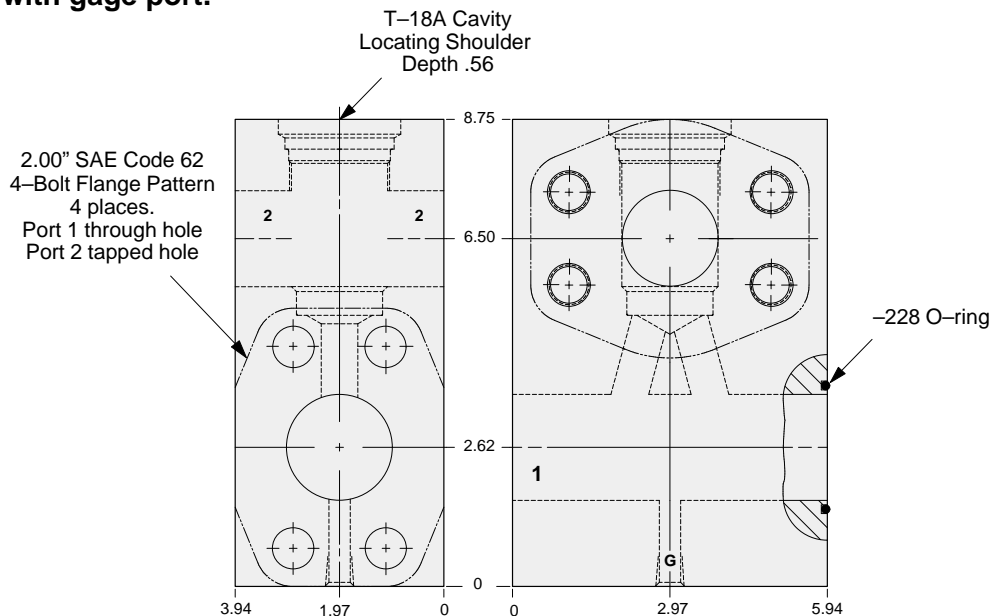

TYPICAL CARTRIDGES USED WITH THIS BODY

- RPKC - *** Page 1.07
- RPKE - *** Page 1.09
- RDJA - *** Page 1.11
- RQKB - *** Page 1.13
- RPKD - *** Page 1.15

Cartridge seal type determines O-ring type.

Instructions for ordering complete cartridge and body assemblies. Page v

Pressure ratings, material specifications. Page 11.02

SAE Specifications Page 11.03

Mounting Hole Dimensions	Gage Port	ALUMINUM		DUCTILE IRON	
		Part Number	List Price	Part Number	List Price
Inch	.25 NPTF	ZBG		ZBG/S	
Metric	.25 BSPP	ZBG/M		ZBG/T	



LINE MOUNT BODIES



- Aluminum rated to 3000 psi.
- Ductile Iron rated to 5000 psi.

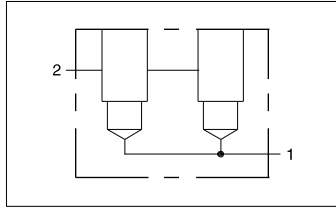

Two cavity 2.00" SAE Code 61 flange port high capacity body.

TYPICAL CARTRIDGES USED WITH THIS BODY

- RPKC - *** Page 1.07
- RPKE - *** Page 1.09
- RDJA - *** Page 1.11
- RQKB - *** Page 1.13
- RPKD - *** Page 1.15

Instructions for ordering complete cartridge and body assemblies. Page v

Pressure ratings, material specifications. Page 11.02

SAE Specifications Page 11.03

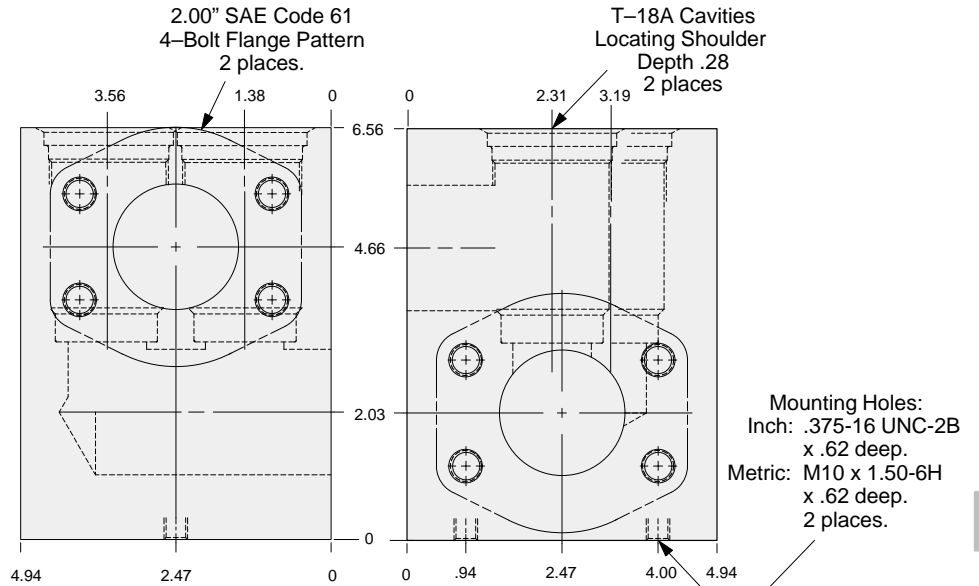

S4
T18A

Mounting Hole Dimensions	ALUMINUM		DUCTILE IRON	
	Part Number	List Price	Part Number	List Price
Inch	XZY		XZY/S	
Metric	XZY/M		XZY/T	



LINE MOUNT BODIES



- Aluminum rated to 3000 psi.
- Ductile Iron rated to 5000 psi.

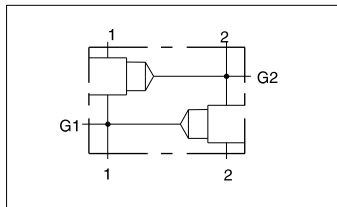

Two cavity 1.50" SAE Code 61 flange port body with gage ports for cross port relief applications.

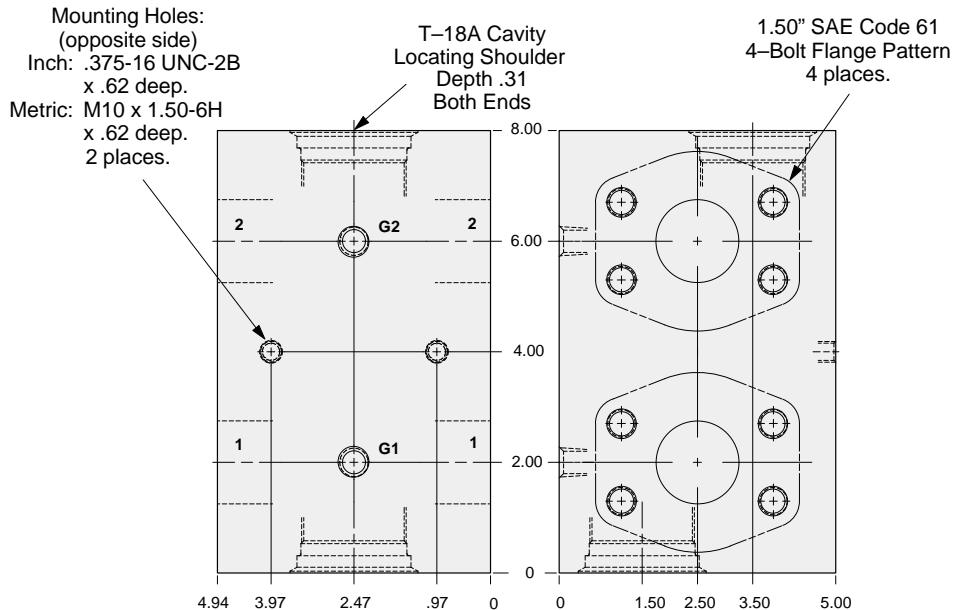

TYPICAL CARTRIDGES USED WITH THIS BODY

- RPKC - *** Page 1.07
RPKE - *** Page 1.09
RDJA - *** Page 1.11
RQKB - *** Page 1.13

Instructions for ordering complete cartridge and body assemblies. Page v

Pressure ratings, material specifications. Page 11.02

SAE Specifications Page 11.03

Mounting Hole Dimensions	Gage Ports	ALUMINUM		DUCTILE IRON	
		Part Number	List Price	Part Number	List Price
Inch	.25 NPTF	YLR		YLR/S	
Metric	.25 BSPP	YLR/M		YLR/T	

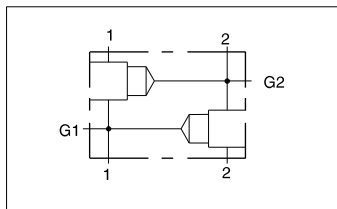

Two cavity 1.50" SAE Code 62 flange port body with gage ports for cross port relief applications.

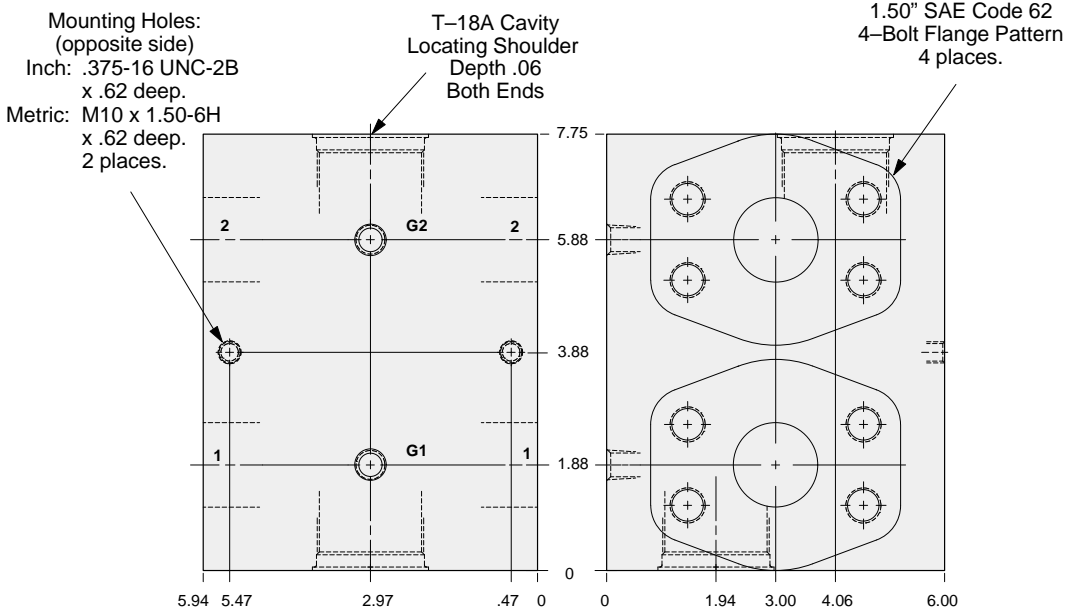

TYPICAL CARTRIDGES USED WITH THIS BODY

- RPKC - *** Page 1.07
RPKE - *** Page 1.09
RDJA - *** Page 1.11
RQKB - *** Page 1.13

Instructions for ordering complete cartridge and body assemblies. Page v

Pressure ratings, material specifications. Page 11.02

SAE Specifications Page 11.03

Mounting Hole Dimensions	Gage Ports	ALUMINUM		DUCTILE IRON	
		Part Number	List Price	Part Number	List Price
Inch	.25 NPTF	YL6		YL6/S	
Metric	.25 BSPP	YL6/M		YL6/T	



LINE MOUNT BODIES



- Aluminum rated to 3000 psi.
- Ductile Iron rated to 5000 psi.

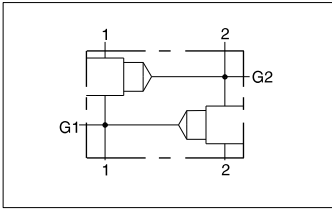

Two cavity 2.00" SAE Code 61 flange port body with gage ports for cross port relief applications.

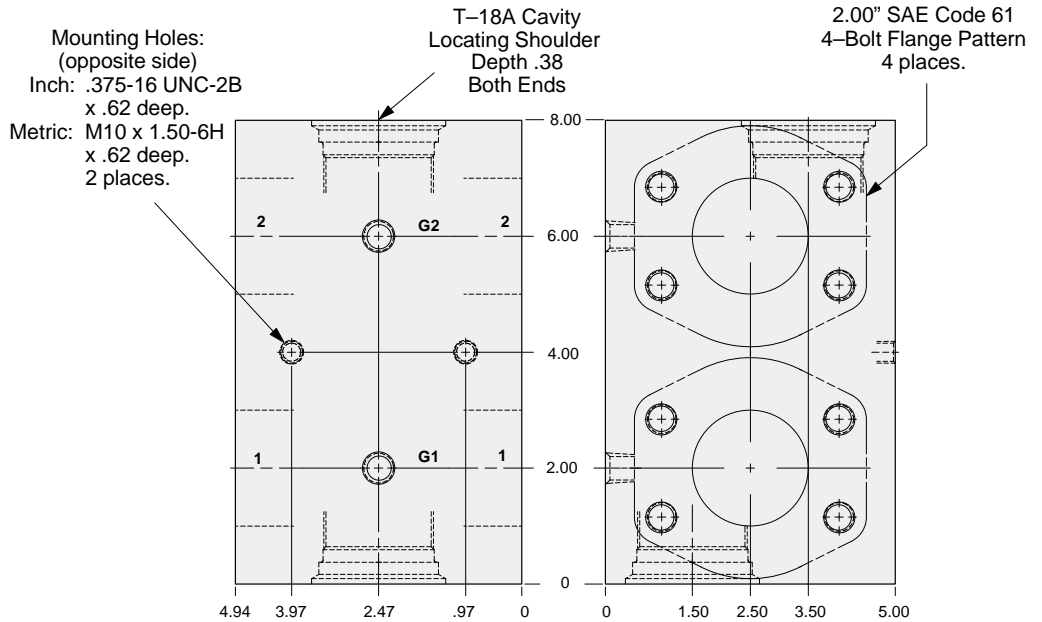

TYPICAL CARTRIDGES USED WITH THIS BODY

- RPKC - *** Page 1.07
RPKE - *** Page 1.09
RDJA - *** Page 1.11
RQKB - *** Page 1.13

Instructions for ordering complete cartridge and body assemblies. Page v

Pressure ratings, material specifications. Page 11.02

SAE Specifications Page 11.03

Mounting Hole Dimensions	Gage Ports	ALUMINUM		DUCTILE IRON	
		Part Number	List Price	Part Number	List Price
Inch	.25 NPTF	YLS		YLS/S	
Metric	.25 BSPP	YLS/M		YLS/T	

S4
T18A

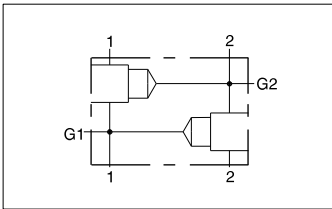

Two cavity 2.00" SAE Code 62 flange port body with gage ports for cross port relief applications.

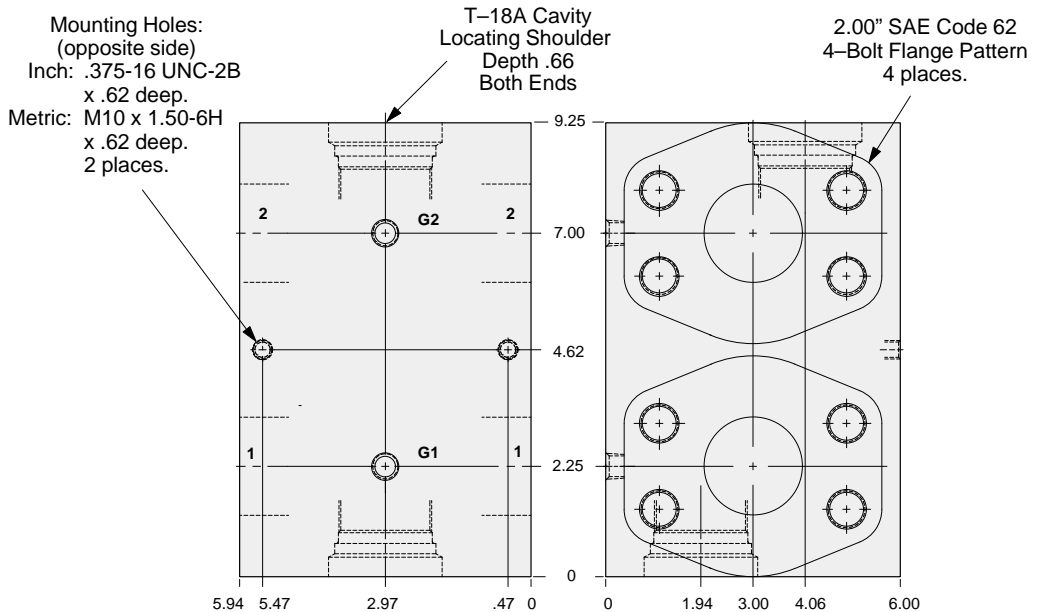

TYPICAL CARTRIDGES USED WITH THIS BODY

- RPKC - *** Page 1.07
RPKE - *** Page 1.09
RDJA - *** Page 1.11
RQKB - *** Page 1.13

Instructions for ordering complete cartridge and body assemblies. Page v

Pressure ratings, material specifications. Page 11.02

SAE Specifications Page 11.03

Mounting Hole Dimensions	Gage Ports	ALUMINUM		DUCTILE IRON	
		Part Number	List Price	Part Number	List Price
Inch	.25 NPTF	YL8		YL8/S	
Metric	.25 BSPP	YL8/M		YL8/T	



LINE MOUNT BODIES



- Aluminum rated to 3000 psi.
- Ductile Iron rated to 5000 psi.

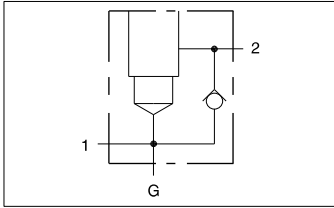

Body with reverse free flow check.

T-18A Cavity
Locating Shoulder
Depth .06

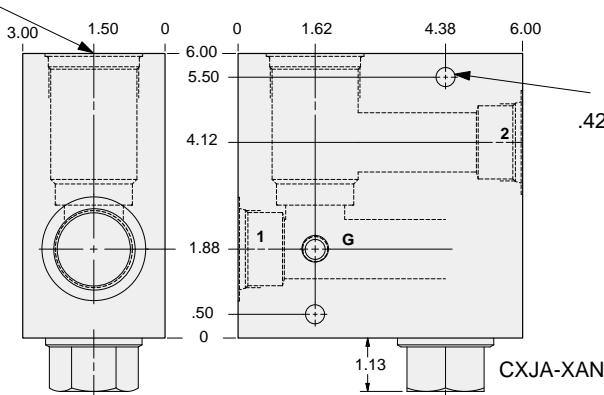

Mounting Holes:
.42 diameter through hole.
2 places.

TYPICAL CARTRIDGES USED WITH THIS BODY

RPKC - ***	Page 1.07
RPKE - ***	Page 1.09
RDJA - ***	Page 1.11
RQKB - ***	Page 1.13
RPKD - ***	Page 1.15

Cartridge seal type determines check valve seal type.

Instructions for ordering complete cartridge and body assemblies. Page v

S4
T18A

Pressure ratings, material specifications. Page 11.02

Mounting Hole Dimensions	Ports 1 & 2	Gage Port	ALUMINUM		DUCTILE IRON	
			Part Number	List Price	Part Number	List Price
Inch	.75 NPTF	.25 NPTF	LND		LND/S	
Inch	1.00 NPTF	.25 NPTF	LNE		LNE/S	
Inch	1.25 NPTF	.25 NPTF	LNF		LNF/S	
Inch	SAE-12	.25 NPTF	LNL		LNL/S	
Inch	SAE-16	.25 NPTF	LNM		LNM/S	
Inch	SAE-20	.25 NPTF	LNN		LNN/S	
Metric	.75 BSPP	.25 BSPP	LNW		LNW/S	
Metric	1.00 BSPP	.25 BSPP	LNX		LNX/S	
Metric	1.25 BSPP	.25 BSPP	LNy		LNy/S	



LINE MOUNT BODIES



- Aluminum rated to 3000 psi.
- Ductile Iron rated to 5000 psi.

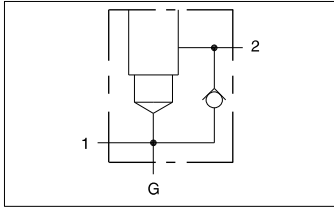

1.25" SAE Code 61 flange port body with reverse free flow check for relief applications.

TYPICAL CARTRIDGES USED WITH THIS BODY

RPKC - ***	Page 1.07
RPKE - ***	Page 1.09
RDJA - ***	Page 1.11
RQKB - ***	Page 1.13
RPKD - ***	Page 1.15

Cartridge seal type determines check valve seal type.

Instructions for ordering complete cartridge and body assemblies. Page v

Pressure ratings, material specifications. Page 11.02

SAE Specifications Page 11.03

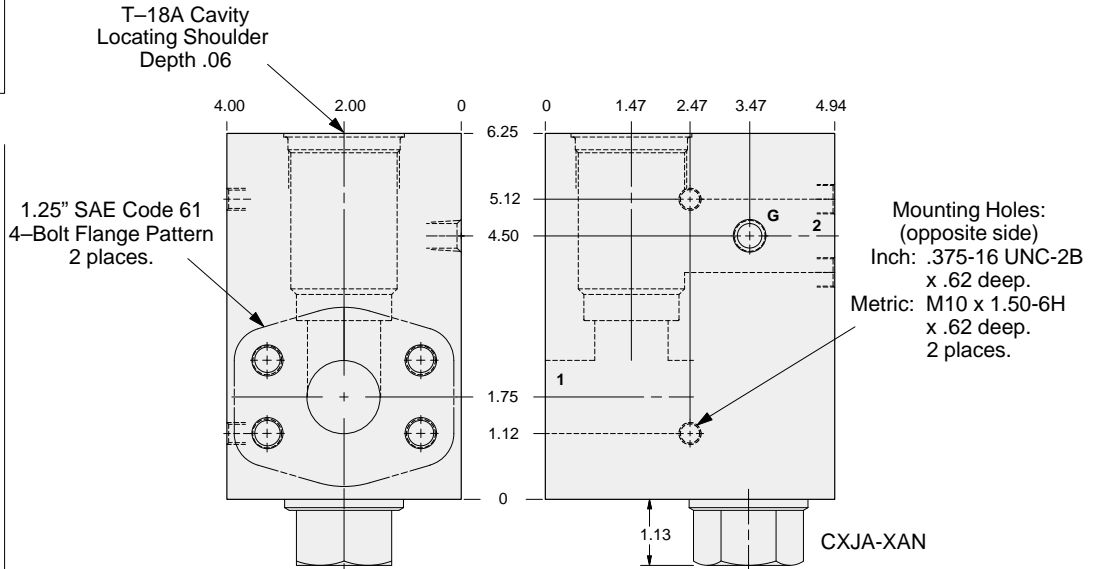

Mounting Hole Dimensions	Gage Port	ALUMINUM		DUCTILE IRON	
		Part Number	List Price	Part Number	List Price
Inch	.25 NPTF	LNQ		LNQ/S	
Metric	.25 BSPP	LNQ/M		LNQ/T	

S4
T18A

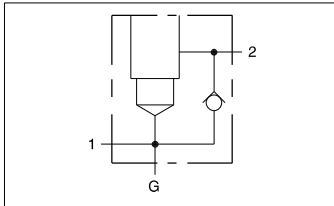

1.25" SAE Code 62 flange port body with reverse free flow check for relief applications.

TYPICAL CARTRIDGES USED WITH THIS BODY

RPKC - ***	Page 1.07
RPKE - ***	Page 1.09
RDJA - ***	Page 1.11
RQKB - ***	Page 1.13
RPKD - ***	Page 1.15

Cartridge seal type determines check valve seal type.

Instructions for ordering complete cartridge and body assemblies. Page v

Pressure ratings, material specifications. Page 11.02

SAE Specifications Page 11.03

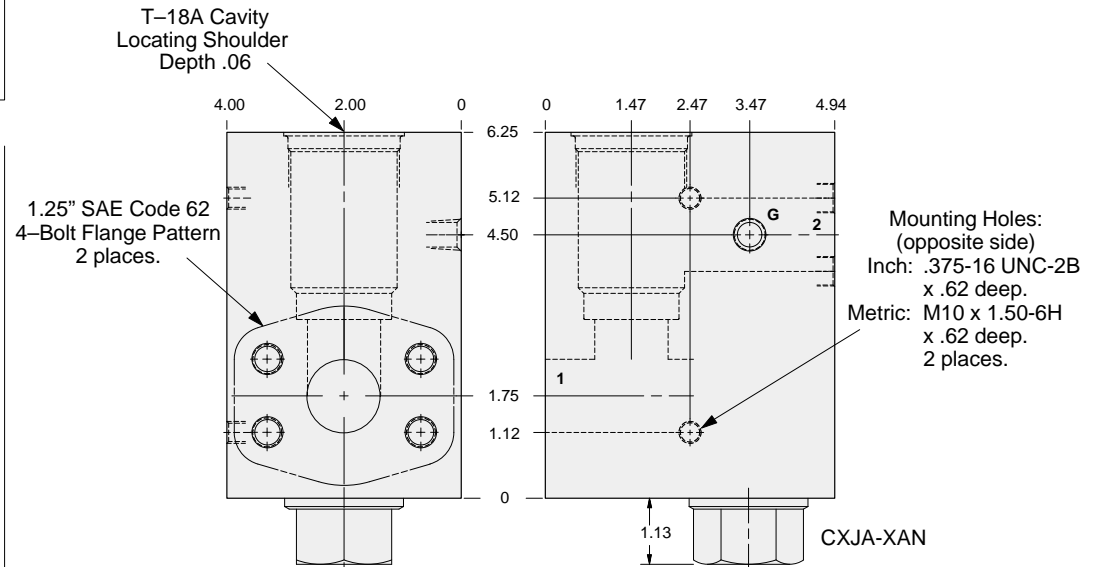

Mounting Hole Dimensions	Gage Port	ALUMINUM		DUCTILE IRON	
		Part Number	List Price	Part Number	List Price
Inch	.25 NPTF	LN5		LN5/S	
Metric	.25 BSPP	LN5/M		LN5/T	



LINE MOUNT BODIES



- Aluminum rated to 3000 psi.
- Ductile Iron rated to 5000 psi.

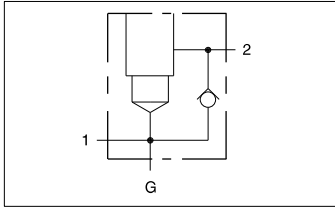

1.50" SAE Code 61 flange port body with reverse free flow check for relief applications.

Mounting Holes:
(opposite side)
Inch: .375-16 UNC-2B
x .62 deep.
Metric: M10 x 1.50-6H
x .62 deep.
2 places.

T-18A Cavity
Locating Shoulder
Depth .06

1.50" SAE Code 61
4-Bolt Flange Pattern
2 places.

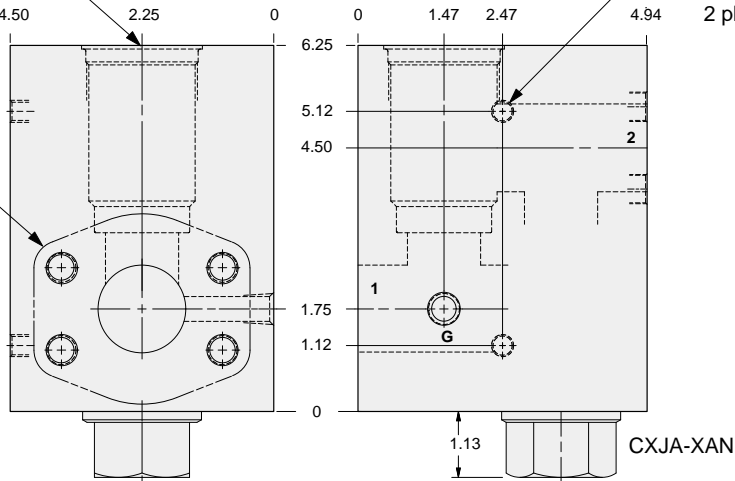

TYPICAL CARTRIDGES USED WITH THIS BODY

- | | |
|------------|-----------|
| RPKC - *** | Page 1.07 |
| RPKE - *** | Page 1.09 |
| RDJA - *** | Page 1.11 |
| RQKB - *** | Page 1.13 |
| RPKD - *** | Page 1.15 |

Cartridge seal type determines check valve seal type.

Instructions for ordering complete cartridge and body assemblies. Page v

Pressure ratings, material specifications. Page 11.02

SAE Specifications Page 11.03

Mounting Hole Dimensions	Gage Port	ALUMINUM		DUCTILE IRON	
		Part Number	List Price	Part Number	List Price
Inch	.25 NPTF	LNR		LNR/S	
Metric	.25 BSPP	LNR/M		LNR/T	

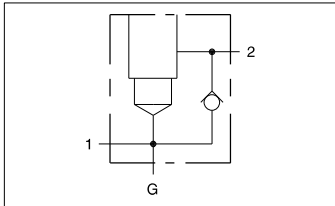

1.50" SAE Code 62 flange port body with reverse free flow check for relief applications.

Mounting Holes:
(opposite side)
Inch: .375-16 UNC-2B
x .62 deep.
Metric: M10 x 1.50-6H
x .62 deep.
2 places.

T-18A Cavity
Locating Shoulder
Depth .19

1.50" SAE Code 62
4-Bolt Flange Pattern
2 places.

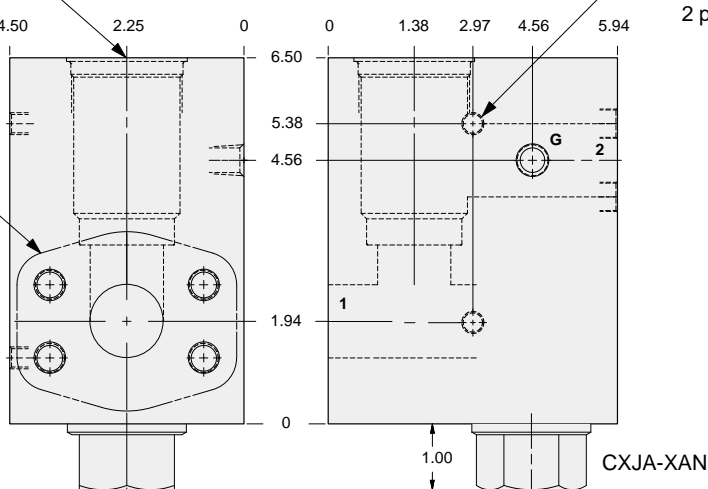

TYPICAL CARTRIDGES USED WITH THIS BODY

- | | |
|------------|-----------|
| RPKC - *** | Page 1.07 |
| RPKE - *** | Page 1.09 |
| RDJA - *** | Page 1.11 |
| RQKB - *** | Page 1.13 |
| RPKD - *** | Page 1.15 |

Cartridge seal type determines check valve seal type.

Instructions for ordering complete cartridge and body assemblies. Page v

Pressure ratings, material specifications. Page 11.02

SAE Specifications Page 11.03

Mounting Hole Dimensions	Gage Port	ALUMINUM		DUCTILE IRON	
		Part Number	List Price	Part Number	List Price
Inch	.25 NPTF	LN6		LN6/S	
Metric	.25 BSPP	LN6/M		LN6/T	



LINE MOUNT BODIES



- Aluminum rated to 3000 psi.
- Ductile Iron rated to 5000 psi.

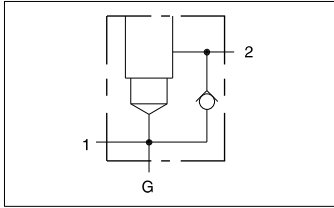

2.00" SAE Code 61 flange port body with reverse free flow check for relief applications.

Mounting Holes:
(opposite side)
Inch: .375-16 UNC-2B
x .62 deep.
Metric: M10 x 1.50-6H
x .62 deep.
2 places.

T-18A Cavity
Locating Shoulder
Depth .31

2.00" SAE Code 61
4-Bolt Flange Pattern
2 places.

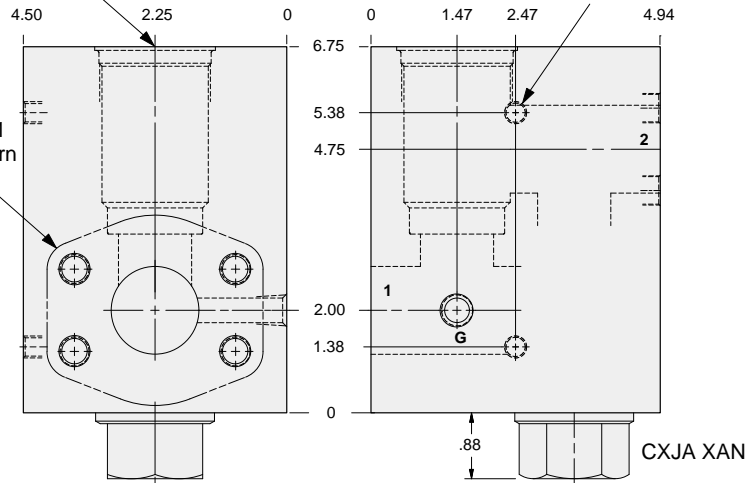

TYPICAL CARTRIDGES USED WITH THIS BODY

RPKC - ***	Page 1.07
RPKE - ***	Page 1.09
RDJA - ***	Page 1.11
RQKB - ***	Page 1.13
RPKD - ***	Page 1.15

Cartridge seal type determines check valve seal type.

Instructions for ordering complete cartridge and body assemblies. Page v

Pressure ratings, material specifications. Page 11.02

SAE Specifications Page 11.03

Mounting Hole Dimensions	Gage Port	ALUMINUM		DUCTILE IRON	
		Part Number	List Price	Part Number	List Price
Inch	.25 NPTF	LNS		LNS/S	
Metric	.25 BSPP	LNS/M		LNS/T	

S4
T18A

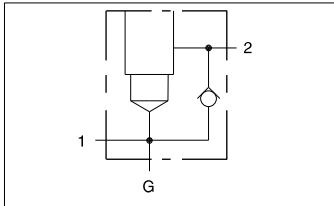

2.00" SAE Code 62 flange port body with reverse free flow check for relief applications.

Mounting Holes:
(opposite side)
Inch: .375-16 UNC-2B
x .62 deep.
Metric: M10 x 1.50-6H
x .62 deep.
2 places.

T-18A Cavity
Locating Shoulder
Depth .56

2.00" SAE Code 62
4-Bolt Flange Pattern
2 places.

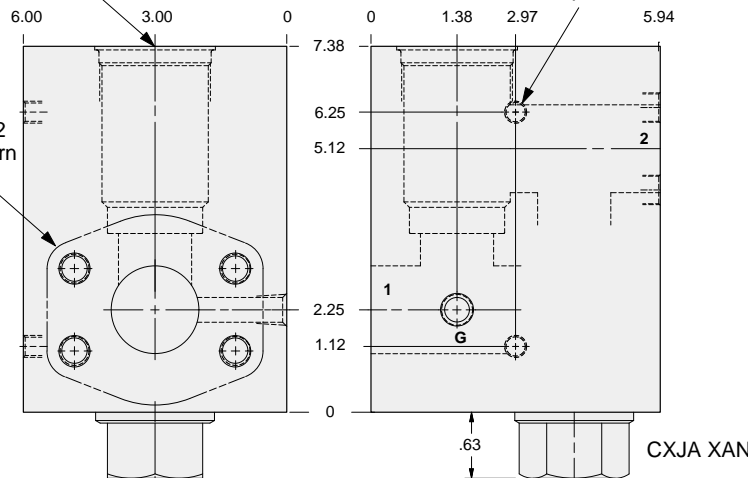

TYPICAL CARTRIDGES USED WITH THIS BODY

RPKC - ***	Page 1.07
RPKE - ***	Page 1.09
RDJA - ***	Page 1.11
RQKB - ***	Page 1.13
RPKD - ***	Page 1.15

Cartridge seal type determines check valve seal type.

Instructions for ordering complete cartridge and body assemblies. Page v

Pressure ratings, material specifications. Page 11.02

SAE Specifications Page 11.03

Mounting Hole Dimensions	Gage Port	ALUMINUM		DUCTILE IRON	
		Part Number	List Price	Part Number	List Price
Inch	.25 NPTF	LN8		LN8/S	
Metric	.25 BSPP	LN8/M		LN8/T	



LINE MOUNT BODIES



- Aluminum rated to 3000 psi.
- Ductile Iron rated to 5000 psi.

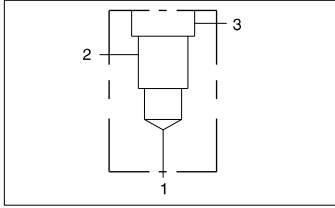

90 degree body.

T-19A Cavity
Locating Shoulder
Depth 1.16

Mounting Holes:
.42 diameter through hole.
2 places.

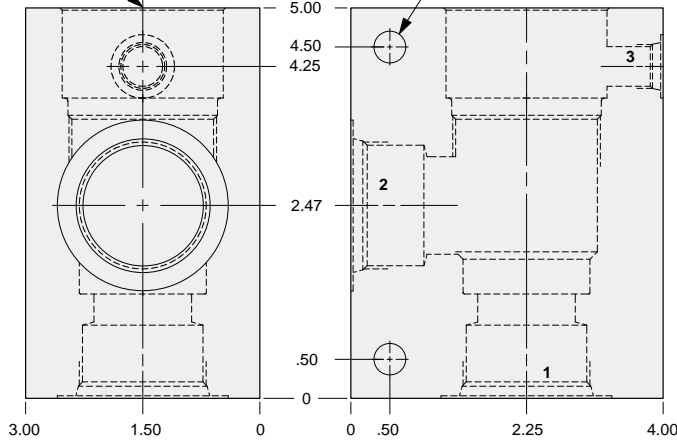

TYPICAL CARTRIDGES USED WITH THIS BODY

RVIA - ***	Page 1.19
RSJC - ***	Page 2.07
SQJB - ***	Page 2.09
RSJE - ***	Page 2.11
SCIA - ***	Page 2.13
PBJB - ***	Page 3.07
PBJC - ***	Page 3.09
CBIA - ***	Page 4.11
CBIG - ***	Page 4.13
CBIH - ***	Page 4.15
CKIB - ***	Page 4.17
LOJC - ***	Page 9.09
LKJC - ***	Page 9.11
LPJC - ***	Page 9.13
LRJC - ***	Page 9.15
COJA - ***	Page 10.13

Ports 1 & 2	Port 3	ALUMINUM		DUCTILE IRON	
		Part Number	List Price	Part Number	List Price
1.00 NPTF	.25 NPTF	KCE		KCE/S	
1.25 NPTF	.25 NPTF	KCF		KCF/S	
SAE-16	SAE-6	KCM		KCM/S	
SAE-20	SAE-6	KCN		KCN/S	
1.00 BSPP	.25 BSPP	KCX		KCX/S	
1.25 BSPP	.25 BSPP	KCY		KCY/S	

S4
T19A

Instructions for ordering complete cartridge and body assemblies. Page v

Pressure ratings, material specifications. Page 11.02

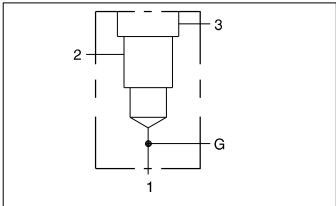

90 degree body with gage port.

T-19A Cavity
Locating Shoulder
Depth 1.16

Mounting Holes:
.42 diameter through hole.
2 places.

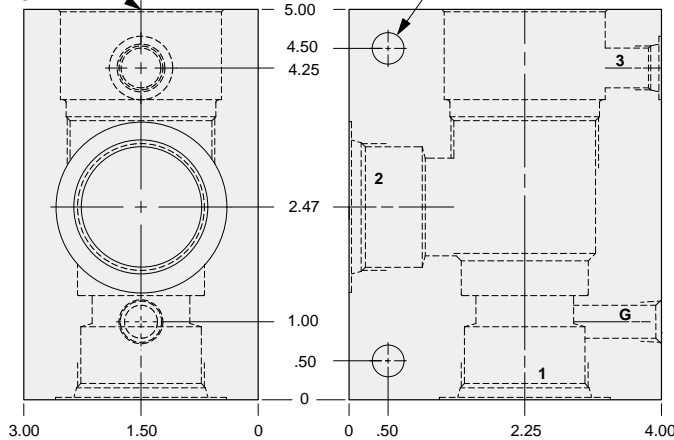

TYPICAL CARTRIDGES USED WITH THIS BODY

RVIA - ***	Page 1.19
RSJC - ***	Page 2.07
SQJB - ***	Page 2.09
RSJE - ***	Page 2.11
SCIA - ***	Page 2.13
PBJB - ***	Page 3.07
PBJC - ***	Page 3.09
LOJC - ***	Page 9.09
LKJC - ***	Page 9.11
LPJC - ***	Page 9.13
LRJC - ***	Page 9.15
COJA - ***	Page 10.13

Instructions for ordering complete cartridge and body assemblies. Page v

Pressure ratings, material specifications. Page 11.02

Ports 1 & 2	Port 3	Gage Port	ALUMINUM		DUCTILE IRON	
			Part Number	List Price	Part Number	List Price
1.00 NPTF	.25 NPTF	.25 NPTF	KFE		KFE/S	
1.25 NPTF	.25 NPTF	.25 NPTF	KFF		KFF/S	
SAE-16	SAE-6	.25 NPTF	KFM		KFM/S	
SAE-20	SAE-6	.25 NPTF	KFN		KFN/S	
1.00 BSPP	.25 BSPP	.25 BSPP	KFX		KFX/S	
1.25 BSPP	.25 BSPP	.25 BSPP	KFY		KFY/S	



LINE MOUNT BODIES



- Aluminum rated to 3000 psi.
- Ductile Iron rated to 5000 psi.

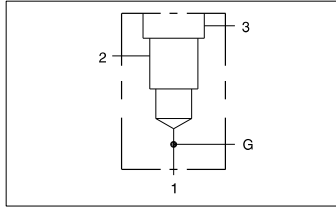

90 degree body with high capacity port 3 and gage port.

T-19A Cavity
Locating Shoulder
Depth 1.38

Mounting Holes:
.42 diameter through hole.
2 places.

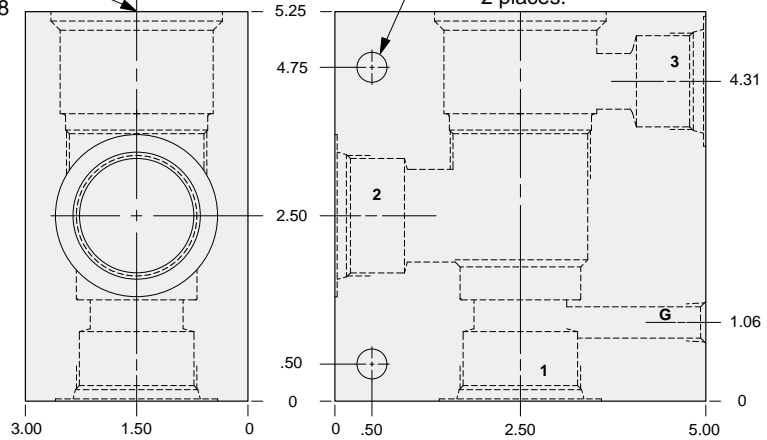

TYPICAL CARTRIDGES USED WITH THIS BODY

- PPJB - *** Page 3.11
PPJC - *** Page 3.13
FRFA - *** Page 6.03

Instructions for ordering complete cartridge and body assemblies. Page v

Pressure ratings, material specifications. Page 11.02

Ports 1 & 2	Port 3	Gage Port	ALUMINUM		DUCTILE IRON	
			Part Number	List Price	Part Number	List Price
1.00 NPTF	1.00 NPTF	.25 NPTF	KEE		KEE/S	
1.25 NPTF	1.00 NPTF	.25 NPTF	KEF		KEF/S	
SAE-16	SAE-16	.25 NPTF	KEM		KEM/S	
SAE-20	SAE-16	.25 NPTF	KEN		KEN/S	
1.00 BSPP	1.00 BSPP	.25 BSPP	KEX		KEX/S	
1.25 BSPP	1.00 BSPP	.25 BSPP	KEY		KEY/S	

S4
T19A

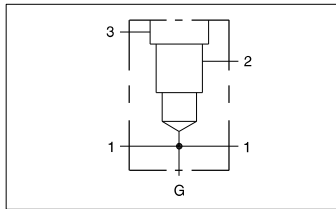

Through port body with gage port.

Mounting Holes:
Inch: .375-16 UNC-2B
x .62 deep.
Metric: M10 x 1.50-6H
x .75 deep.
2 places.

T-19A Cavity
Locating Shoulder
Depth 1.16

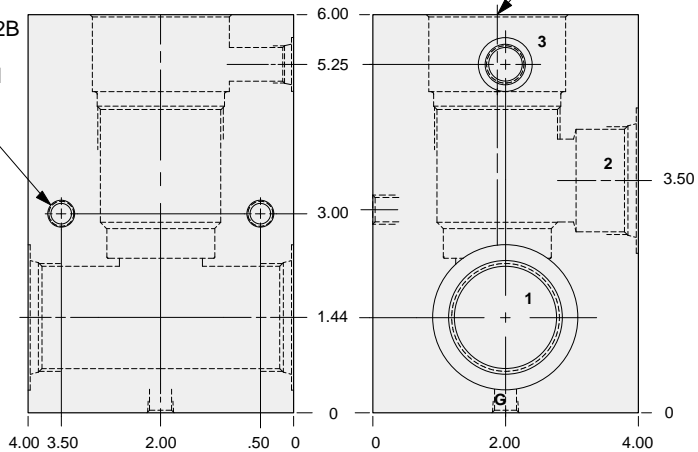

TYPICAL CARTRIDGES USED WITH THIS BODY

- RVIA - *** Page 1.19
RSJC - *** Page 2.07
SQJB - *** Page 2.09
RSJE - *** Page 2.11
SCIA - *** Page 2.13
PBBJ - *** Page 3.07
PBJC - *** Page 3.09

Instructions for ordering complete cartridge and body assemblies. Page v

Pressure ratings, material specifications. Page 11.02

Mounting Hole Dimensions	Ports 1 & 2	Port 3	Gage Port	ALUMINUM		DUCTILE IRON	
				Part Number	List Price	Part Number	List Price
Inch	1.00 NPTF	.25 NPTF	.25 NPTF	KHE		KHE/S	
Inch	1.25 NPTF	.25 NPTF	.25 NPTF	KHF		KHF/S	
Inch	SAE-16	SAE-6	.25 NPTF	KHM		KHM/S	
Inch	SAE-20	SAE-6	.25 NPTF	KHN		KHN/S	
Metric	1.00 BSPP	.25 BSPP	.25 BSPP	KHX		KHX/S	
Metric	1.25 BSPP	.25 BSPP	.25 BSPP	KHY		KHY/S	



LINE MOUNT BODIES



- Aluminum rated to 3000 psi.
- Ductile Iron rated to 5000 psi.

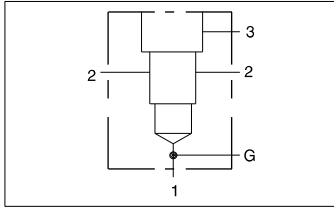

Through port body with gage port for reducing applications.

Mounting Holes:
(opposite side)
Inch: .375-16 UNC-2B
x .62 deep.
Metric: M10 x 1.50-6H
x .62 deep.
2 places.

T-19A Cavity
Locating Shoulder
Depth 1.38

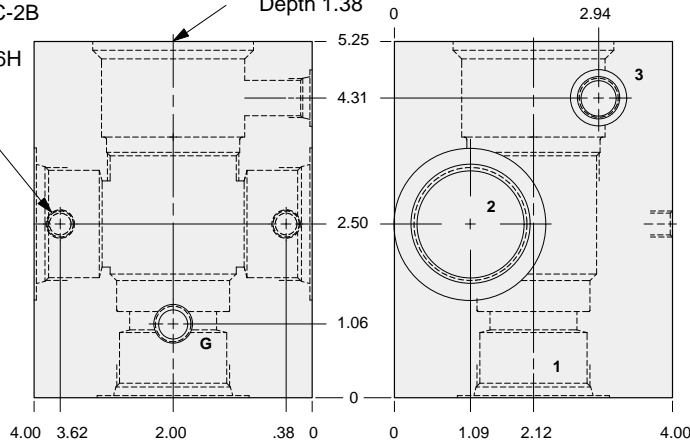

TYPICAL CARTRIDGES USED WITH THIS BODY

PBJB - *** Page 3.07
PBJC - *** Page 3.09

Instructions for ordering complete cartridge and body assemblies. Page v

Pressure ratings, material specifications. Page 11.02

Mounting Hole Dimensions	Ports 1 & 2	Port 3	Gage Port	ALUMINUM		DUCTILE IRON	
				Part Number	List Price	Part Number	List Price
Inch	1.00 NPTF	.25 NPTF	.25 NPTF	WTO		WTO/S	
Inch	1.25 NPTF	.25 NPTF	.25 NPTF	WTP		WTP/S	
Inch	SAE-16	SAE-6	.25 NPTF	WTQ		WTQ/S	
Inch	SAE-20	SAE-6	.25 NPTF	WTR		WTR/S	
Metric	1.00 BSPP	.25 BSPP	.25 BSPP	WTS		WTS/S	
Metric	1.25 BSPP	.25 BSPP	.25 BSPP	WTT		WTT/S	

S4
T19A

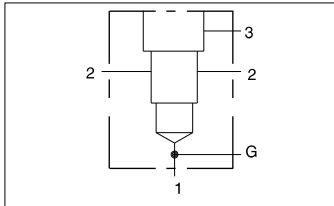

Through port body with high capacity port 3 and gage port for reducing/relieving applications.

Mounting Holes:
(opposite side)
Inch: .375-16 UNC-2B
x .62 deep.
Metric: M10 x 1.50-6H
x .62 deep.
2 places.

T-19A Cavity
Locating Shoulder
Depth 1.38

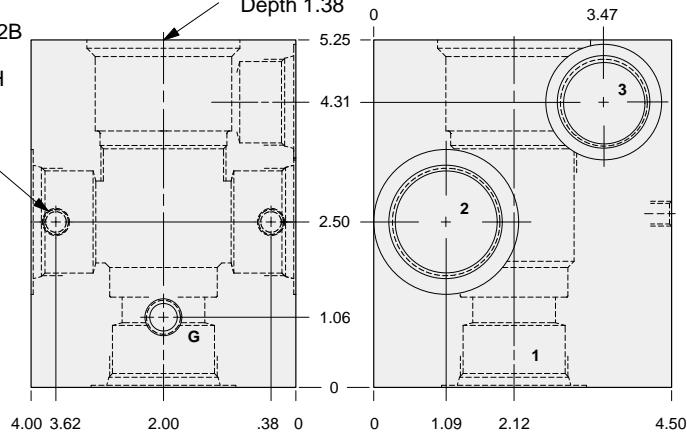

TYPICAL CARTRIDGES USED WITH THIS BODY

PPJB - *** Page 3.11
PPJC - *** Page 3.13
FRFA - *** Page 6.03

Instructions for ordering complete cartridge and body assemblies. Page v

Pressure ratings, material specifications. Page 11.02

Mounting Hole Dimensions	Ports 1 & 2	Port 3	Gage Port	ALUMINUM		DUCTILE IRON	
				Part Number	List Price	Part Number	List Price
Inch	1.00 NPTF	1.00 NPTF	.25 NPTF	WTU		WTU/S	
Inch	1.25 NPTF	1.00 NPTF	.25 NPTF	WTV		WTV/S	
Inch	SAE-16	SAE-16	.25 NPTF	WTW		WTW/S	
Inch	SAE-20	SAE-16	.25 NPTF	WTX		WTX/S	
Metric	1.00 BSPP	1.00 BSPP	.25 BSPP	WTY		WTY/S	
Metric	1.25 BSPP	1.00 BSPP	.25 BSPP	WTZ		WTZ/S	



LINE MOUNT BODIES



- Aluminum rated to 3000 psi.
- Ductile Iron rated to 5000 psi.

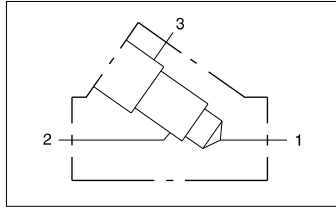

Inline 1.50" SAE Code 61 flange port body.

T-19A Cavity
Locating Shoulder
Depth 1.16

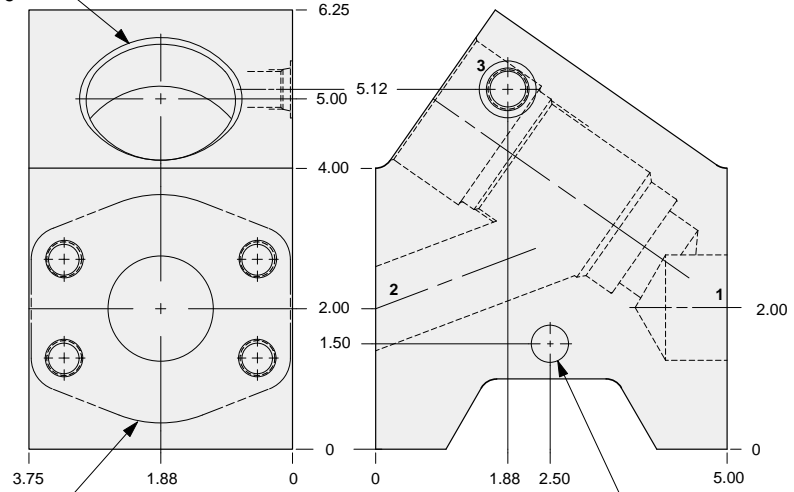

1.50" SAE Code 61
4-Bolt Flange Pattern
2 places.

Mounting Hole:
Inch: .53 diameter through hole.
Metric: .50 diameter through hole.

TYPICAL CARTRIDGES USED WITH THIS BODY

RVIA - ***	Page 1.19
RSJC - ***	Page 2.07
SQJB - ***	Page 2.09
RSJE - ***	Page 2.11
SCIA - ***	Page 2.13
PBJB - ***	Page 3.07
PBJC - ***	Page 3.09
CBIA - ***	Page 4.11
CBIG - ***	Page 4.13
CBIH - ***	Page 4.15
CKIB - ***	Page 4.17
LOJC - ***	Page 9.09
LKJC - ***	Page 9.11
LPJC - ***	Page 9.13
LRJC - ***	Page 9.15
COJA - ***	Page 10.13

Instructions for ordering complete cartridge and body assemblies. Page v

Pressure ratings, material specifications. Page 11.02

SAE Specifications Page 11.03

Mounting Hole Dimensions	Port 3	ALUMINUM		DUCTILE IRON	
		Part Number	List Price	Part Number	List Price
Inch	SAE-6	ZLQ		ZLQ/S	
Metric	.25 BSPP	ZLQ/M		ZLQ/T	

S4
T19A

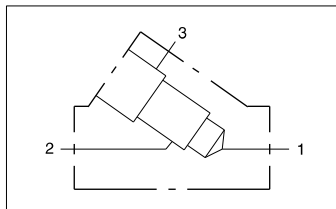

Inline 2.00" SAE Code 61 flange port body.

T-19A Cavity
Locating Shoulder
Depth 1.16

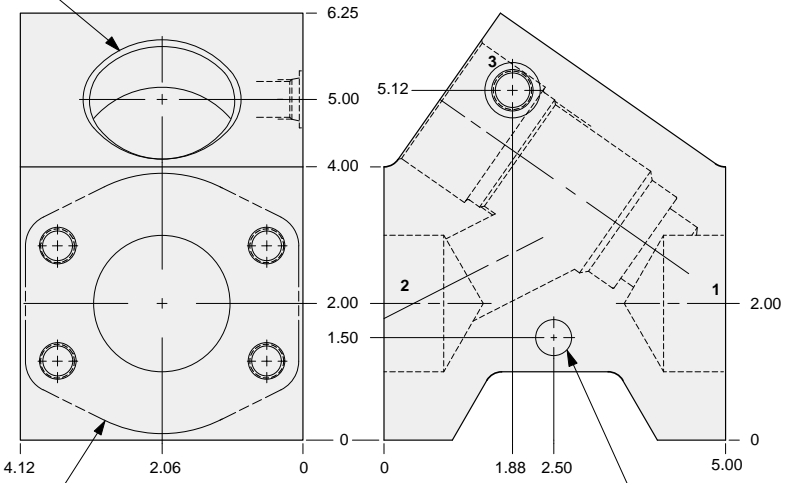

2.00" SAE Code 61
4-Bolt Flange Pattern
2 places.

Mounting Hole:
Inch: .53 diameter through hole.
Metric: .50 diameter through hole.

TYPICAL CARTRIDGES USED WITH THIS BODY

RVIA - ***	Page 1.19
RSJC - ***	Page 2.07
SQJB - ***	Page 2.09
RSJE - ***	Page 2.11
SCIA - ***	Page 2.13
PBJB - ***	Page 3.07
PBJC - ***	Page 3.09
CBIA - ***	Page 4.11
CBIG - ***	Page 4.13
CBIH - ***	Page 4.15
CKIB - ***	Page 4.17
LOJC - ***	Page 9.09
LKJC - ***	Page 9.11
LPJC - ***	Page 9.13
LRJC - ***	Page 9.15
COJA - ***	Page 10.13

Instructions for ordering complete cartridge and body assemblies. Page v

Pressure ratings, material specifications. Page 11.02

SAE Specifications Page 11.03

Mounting Hole Dimensions	Port 3	ALUMINUM		DUCTILE IRON	
		Part Number	List Price	Part Number	List Price
Inch	SAE-6	ZLP		ZLP/S	
Metric	.25 BSPP	ZLP/M		ZLP/T	



LINE MOUNT BODIES



- Aluminum rated to 3000 psi.
- Ductile Iron rated to 5000 psi.

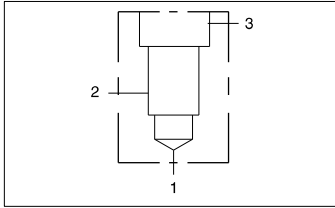

90 degree 1.00" SAE Code 61 flange port body.

1.00" SAE Code 61
4-Bolt Flange Pattern
2 places.

T-19A Cavity
Locating Shoulder
Depth 1.16

Mounting Holes:
(opposite side)
Inch: .375-16 UNC-2B
x .62 deep.
Metric: M10 x 1.50-6H
x .62 deep.
2 places.

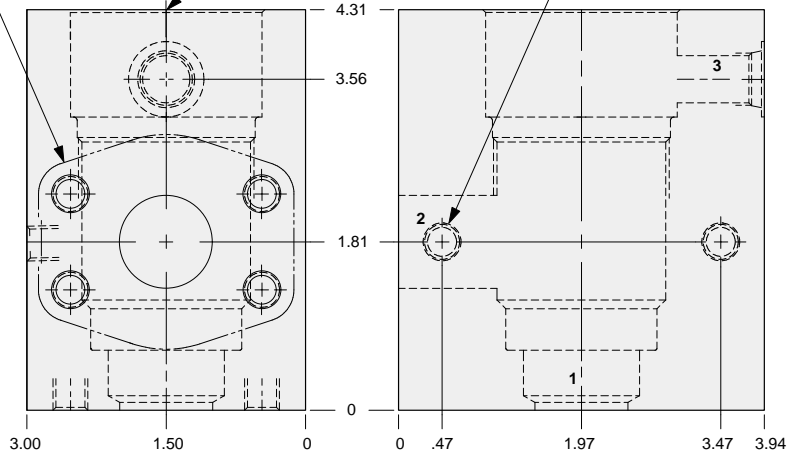

TYPICAL CARTRIDGES USED WITH THIS BODY

RVIA - ***	Page 1.19
RSJC - ***	Page 2.07
SQJB - ***	Page 2.09
RSJE - ***	Page 2.11
SCIA - ***	Page 2.13
PBJB - ***	Page 3.07
PBJC - ***	Page 3.09
CBIA - ***	Page 4.11
CBIG - ***	Page 4.13
CBIH - ***	Page 4.15
CKIB - ***	Page 4.17
LOJC - ***	Page 9.09
LKJC - ***	Page 9.11
LPJC - ***	Page 9.13
LRJC - ***	Page 9.15
COJA - ***	Page 10.13

Instructions for ordering complete cartridge and body assemblies. Page v

Pressure ratings, material specifications. Page 11.02

SAE Specifications Page 11.03

Mounting Hole Dimensions	Port 3	ALUMINUM		DUCTILE IRON	
		Part Number	List Price	Part Number	List Price
Inch	SAE-6	KCP		KCP/S	
Metric	.25 BSPP	KCP/M		KCP/T	

S4
T19A

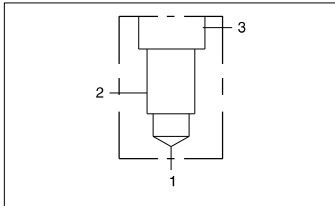

90 degree 1.00" SAE Code 62 flange port body.

1.00" SAE Code 62
4-Bolt Flange Pattern
2 places.

T-19A Cavity
Locating Shoulder
Depth 1.16

Mounting Holes:
(opposite side)
Inch: .375-16 UNC-2B
x .62 deep.
Metric: M10 x 1.50-6H
x .62 deep.
2 places.

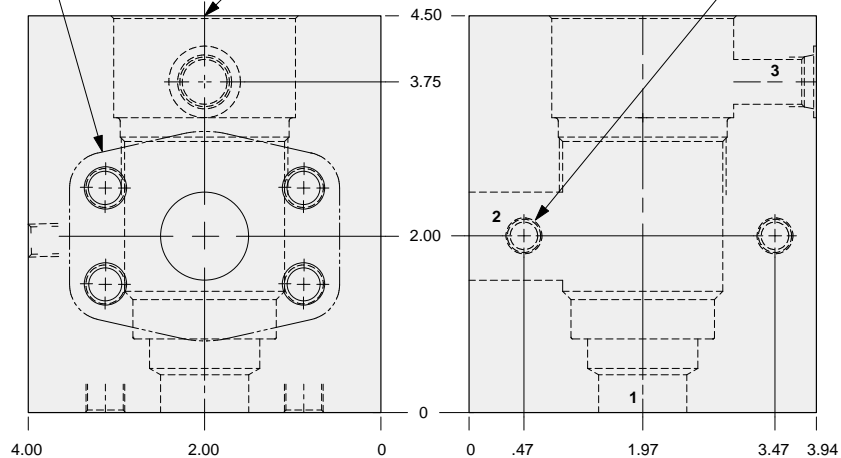

TYPICAL CARTRIDGES USED WITH THIS BODY

RVIA - ***	Page 1.19
RSJC - ***	Page 2.07
SQJB - ***	Page 2.09
RSJE - ***	Page 2.11
SCIA - ***	Page 2.13
PBJB - ***	Page 3.07
PBJC - ***	Page 3.09
CBIA - ***	Page 4.11
CBIG - ***	Page 4.13
CBIH - ***	Page 4.15
CKIB - ***	Page 4.17
LOJC - ***	Page 9.09
LKJC - ***	Page 9.11
LPJC - ***	Page 9.13
LRJC - ***	Page 9.15
COJA - ***	Page 10.13

Instructions for ordering complete cartridge and body assemblies. Page v

Pressure ratings, material specifications. Page 11.02

SAE Specifications Page 11.03

Mounting Hole Dimensions	Port 3	ALUMINUM		DUCTILE IRON	
		Part Number	List Price	Part Number	List Price
Inch	SAE-6	KC4		KC4/S	
Metric	.25 BSPP	KC4/M		KC4/T	



LINE MOUNT BODIES



- Aluminum rated to 3000 psi.
- Ductile Iron rated to 5000 psi.

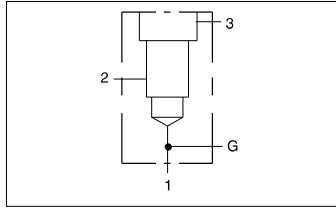

90 degree 1.00" SAE Code 61 flange port body with gage port.

1.00" SAE Code 61
4-Bolt Flange Pattern
2 places.

T-19A Cavity
Locating Shoulder
Depth 1.16

Mounting Holes:
(opposite side)
Inch: .375-16 UNC-2B
x .62 deep.
Metric: M10 x 1.50-6H
x .62 deep.
2 places.

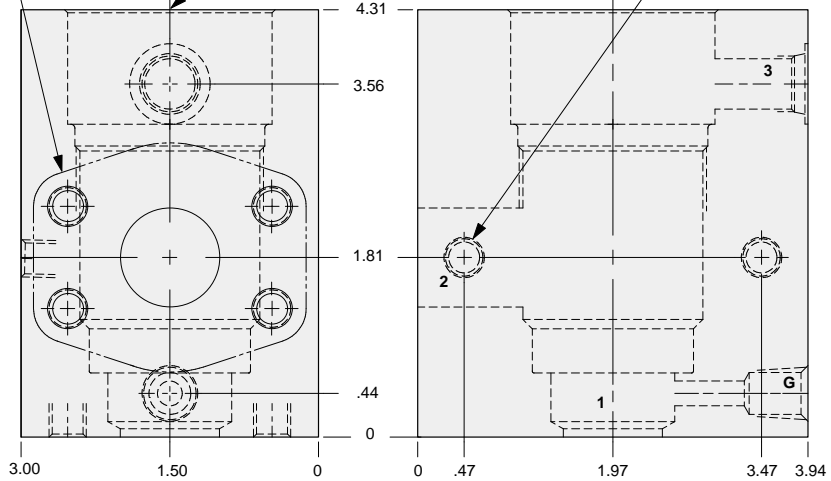

TYPICAL CARTRIDGES USED WITH THIS BODY

RVIA - ***	Page 1.19
RSJC - ***	Page 2.07
SQJB - ***	Page 2.09
RSJE - ***	Page 2.11
SCIA - ***	Page 2.13
PBJB - ***	Page 3.07
PBJC - ***	Page 3.09
CBIA - ***	Page 4.11
CBIG - ***	Page 4.13
CBIH - ***	Page 4.15
CKIB - ***	Page 4.17
LOJC - ***	Page 9.09
LKJC - ***	Page 9.11
LPJC - ***	Page 9.13
LRJC - ***	Page 9.15
COJA - ***	Page 10.13

Instructions for ordering complete cartridge and body assemblies. Page v

Pressure ratings, material specifications. Page 11.02

SAE Specifications Page 11.03

Mounting Hole Dimensions	Port 3	Gage Port	ALUMINUM		DUCTILE IRON	
			Part Number	List Price	Part Number	List Price
Inch	SAE-6	.25 NPTF	KFP		KFP/S	
Metric	.25 BSPP	.25 BSPP	KFP/M		KFP/T	

S4
T19A

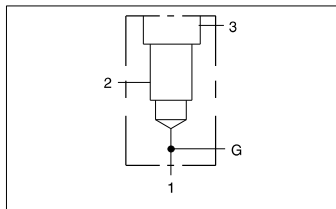

90 degree 1.00" SAE Code 62 flange port body with gage port.

1.00" SAE Code 62
4-Bolt Flange Pattern
2 places.

T-19A Cavity
Locating Shoulder
Depth 1.16

Mounting Holes:
(opposite side)
Inch: .375-16 UNC-2B
x .62 deep.
Metric: M10 x 1.50-6H
x .62 deep.
2 places.

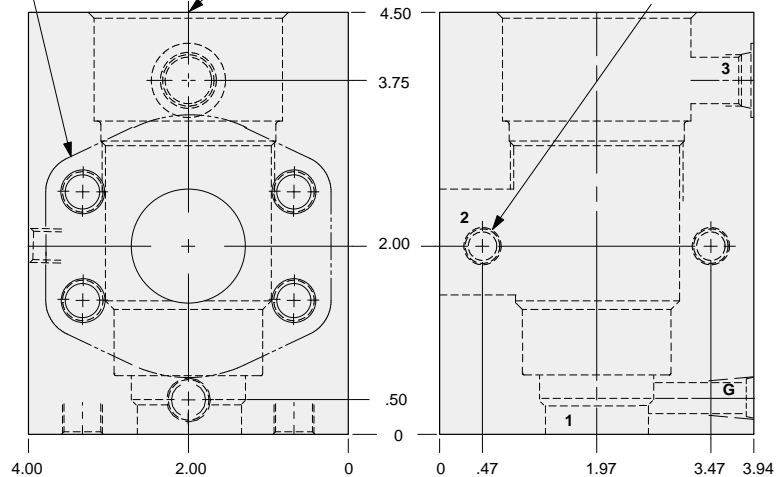

TYPICAL CARTRIDGES USED WITH THIS BODY

RVIA - ***	Page 1.19
RSJC - ***	Page 2.07
SQJB - ***	Page 2.09
RSJE - ***	Page 2.11
SCIA - ***	Page 2.13
PBJB - ***	Page 3.07
PBJC - ***	Page 3.09
CBIA - ***	Page 4.11
CBIG - ***	Page 4.13
CBIH - ***	Page 4.15
CKIB - ***	Page 4.17
LOJC - ***	Page 9.09
LKJC - ***	Page 9.11
LPJC - ***	Page 9.13
LRJC - ***	Page 9.15
COJA - ***	Page 10.13

Instructions for ordering complete cartridge and body assemblies. Page v

Pressure ratings, material specifications. Page 11.02

SAE Specifications Page 11.03

Mounting Hole Dimensions	Port 3	Gage Port	ALUMINUM		DUCTILE IRON	
			Part Number	List Price	Part Number	List Price
Inch	SAE-6	.25 NPTF	KF4		KF4/S	
Metric	.25 BSPP	.25 BSPP	KF4/M		KF4/T	



LINE MOUNT BODIES



- Aluminum rated to 3000 psi.
- Ductile Iron rated to 5000 psi.

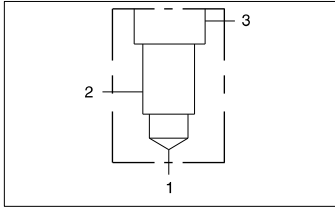

90 degree 1.25" SAE Code 61 flange port body.

1.25" SAE Code 61
4-Bolt Flange Pattern
2 places.

T-19A Cavity
Locating Shoulder
Depth 1.19

Mounting Holes:
(opposite side)
Inch: .375-16 UNC-2B
x .62 deep.
Metric: M10 x 1.50-6H
x .62 deep.
2 places.

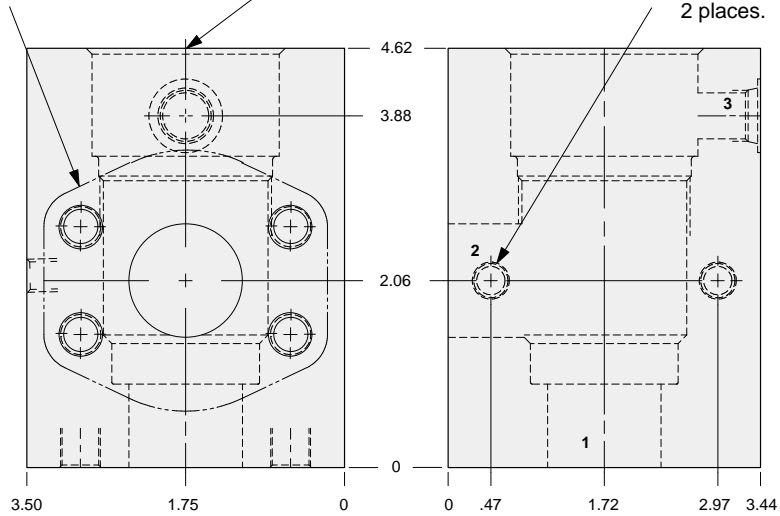

Mounting Hole Dimensions	Port 3	ALUMINUM		DUCTILE IRON	
		Part Number	List Price	Part Number	List Price
Inch	SAE-6	KCQ		KCQ/S	
Metric	.25 BSPP	KCQ/M		KCQ/T	

TYPICAL CARTRIDGES USED WITH THIS BODY

RVIA - ***	Page 1.19
RSJC - ***	Page 2.07
SQJB - ***	Page 2.09
RSJE - ***	Page 2.11
SCIA - ***	Page 2.13
PBJB - ***	Page 3.07
PBJC - ***	Page 3.09
CBIA - ***	Page 4.11
CBIG - ***	Page 4.13
CBIH - ***	Page 4.15
CKIB - ***	Page 4.17
LOJC - ***	Page 9.09
LKJC - ***	Page 9.11
LPJC - ***	Page 9.13
LRJC - ***	Page 9.15
COJA - ***	Page 10.13

Instructions for ordering complete cartridge and body assemblies. Page v

Pressure ratings, material specifications. Page 11.02

SAE Specifications Page 11.03

S4
T19A

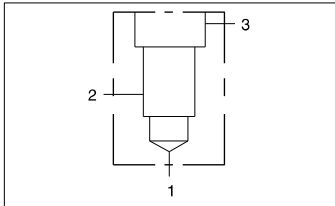

90 degree 1.25" SAE Code 62 flange port body.

1.25" SAE Code 62
4-Bolt Flange Pattern
2 places.

T-19A Cavity
Locating Shoulder
Depth 1.16

Mounting Holes:
(opposite side)
Inch: .375-16 UNC-2B
x .62 deep.
Metric: M10 x 1.50-6H
x .62 deep.
2 places.

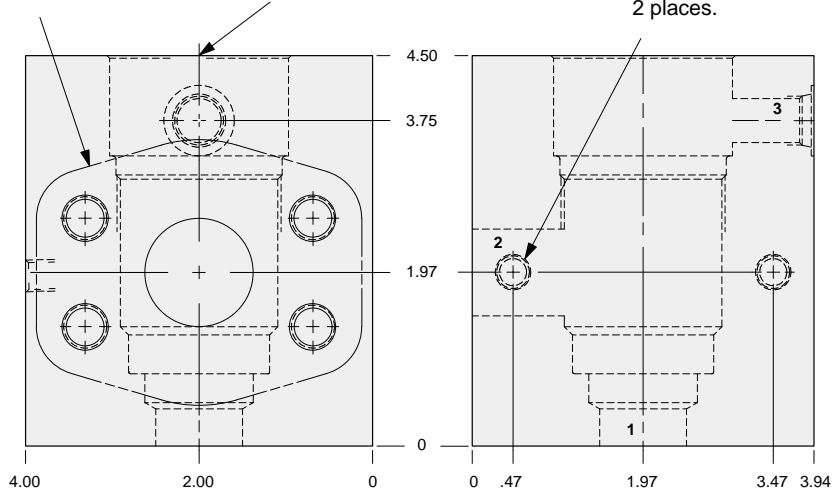

Mounting Hole Dimensions	Port 3	ALUMINUM		DUCTILE IRON	
		Part Number	List Price	Part Number	List Price
Inch	SAE-6	KC5		KC5/S	
Metric	.25 BSPP	KC5/M		KC5/T	

TYPICAL CARTRIDGES USED WITH THIS BODY

RVIA - ***	Page 1.19
RSJC - ***	Page 2.07
SQJB - ***	Page 2.09
RSJE - ***	Page 2.11
SCIA - ***	Page 2.13
PBJB - ***	Page 3.07
PBJC - ***	Page 3.09
CBIA - ***	Page 4.11
CBIG - ***	Page 4.13
CBIH - ***	Page 4.15
CKIB - ***	Page 4.17
LOJC - ***	Page 9.09
LKJC - ***	Page 9.11
LPJC - ***	Page 9.13
LRJC - ***	Page 9.15
COJA - ***	Page 10.13

Instructions for ordering complete cartridge and body assemblies. Page v

Pressure ratings, material specifications. Page 11.02

SAE Specifications Page 11.03



LINE MOUNT BODIES

- Aluminum rated to 3000 psi.
- Ductile Iron rated to 5000 psi.

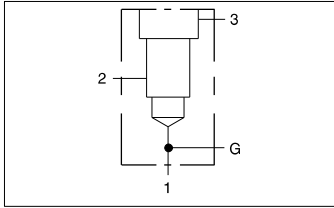

90 degree 1.25" SAE Code 61 flange port body with gage port.

1.25" SAE Code 61
4-Bolt Flange Pattern
2 places.

T-19A Cavity
Locating Shoulder
Depth 1.19

Mounting Holes:
(opposite side)
Inch: .375-16 UNC-2B
x .62 deep.
Metric: M10 x 1.50-6H
x .62 deep.
2 places.

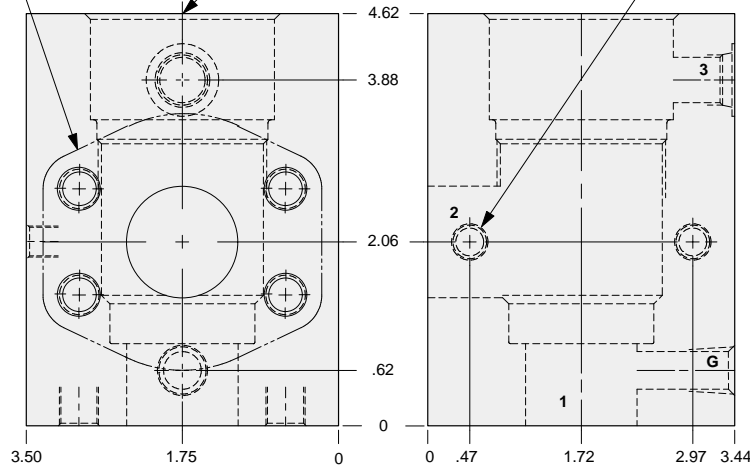

TYPICAL CARTRIDGES USED WITH THIS BODY

RVIA - ***	Page 1.19
RSJC - ***	Page 2.07
SQJB - ***	Page 2.09
RSJE - ***	Page 2.11
SCIA - ***	Page 2.13
PBJB - ***	Page 3.07
PBJC - ***	Page 3.09
CBIA - ***	Page 4.11
CBIG - ***	Page 4.13
CBIH - ***	Page 4.15
CKIB - ***	Page 4.17
LOJC - ***	Page 9.09
LKJC - ***	Page 9.11
LPJC - ***	Page 9.13
LRJC - ***	Page 9.15
COJA - ***	Page 10.13

Instructions for ordering complete cartridge and body assemblies. Page v

Pressure ratings, material specifications. Page 11.02

SAE Specifications Page 11.03

Mounting Hole Dimensions	Port 3	Gage Port	ALUMINUM		DUCTILE IRON	
			Part Number	List Price	Part Number	List Price
Inch	SAE-6	.25 NPTF	KFQ		KFQ/S	
Metric	.25 BSPP	.25 BSPP	KFQ/M		KFQ/T	

S4
T19A

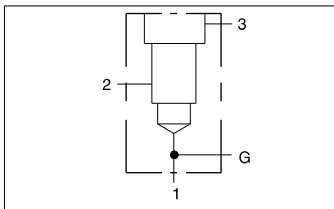

90 degree 1.25" SAE Code 62 flange port body with gage port.

1.25" SAE Code 62
4-Bolt Flange Pattern
2 places.

T-19A Cavity
Locating Shoulder
Depth 1.16

Mounting Holes:
(opposite side)
Inch: .375-16 UNC-2B
x .62 deep.
Metric: M10 x 1.50-6H
x .62 deep.
2 places.

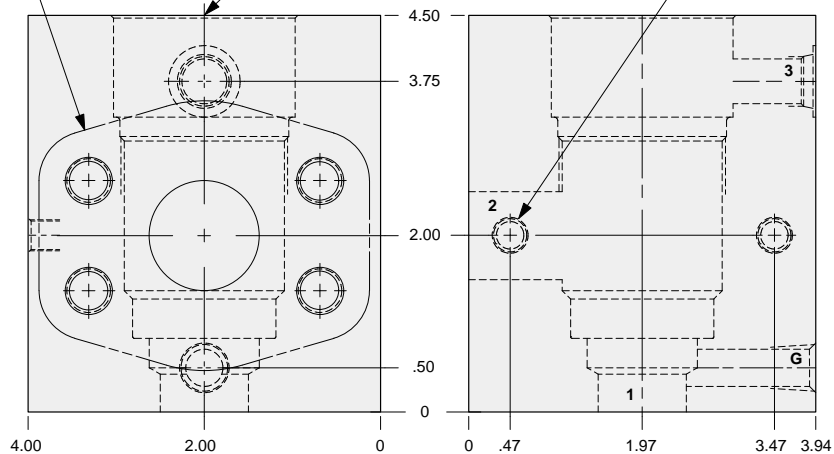

TYPICAL CARTRIDGES USED WITH THIS BODY

RVIA - ***	Page 1.19
RSJC - ***	Page 2.07
SQJB - ***	Page 2.09
RSJE - ***	Page 2.11
SCIA - ***	Page 2.13
PBJB - ***	Page 3.07
PBJC - ***	Page 3.09
CBIA - ***	Page 4.11
CBIG - ***	Page 4.13
CBIH - ***	Page 4.15
CKIB - ***	Page 4.17
LOJC - ***	Page 9.09
LKJC - ***	Page 9.11
LPJC - ***	Page 9.13
LRJC - ***	Page 9.15
COJA - ***	Page 10.13

Instructions for ordering complete cartridge and body assemblies. Page v

Pressure ratings, material specifications. Page 11.02

SAE Specifications Page 11.03

Mounting Hole Dimensions	Port 3	Gage Port	ALUMINUM		DUCTILE IRON	
			Part Number	List Price	Part Number	List Price
Inch	SAE-6	.25 NPTF	KF5		KF5/S	
Metric	.25 BSPP	.25 BSPP	KF5/M		KF5/T	



LINE MOUNT BODIES



- Aluminum rated to 3000 psi.
- Ductile Iron rated to 5000 psi.

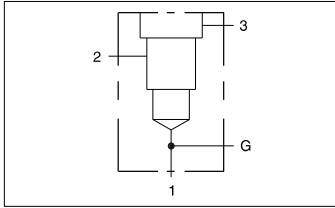

90 degree 1.25" SAE Code 61 flange port body with high capacity port 3 and gage port.

Mounting Holes:
(opposite side)
Inch: .375-16 UNC-2B
x .62 deep.
Metric: M10 x 1.50-6H
x .62 deep.
2 places.

1.25" SAE Code 61
4-Bolt Flange Pattern
3 places.

T-19A Cavity
Locating Shoulder
Depth 1.88

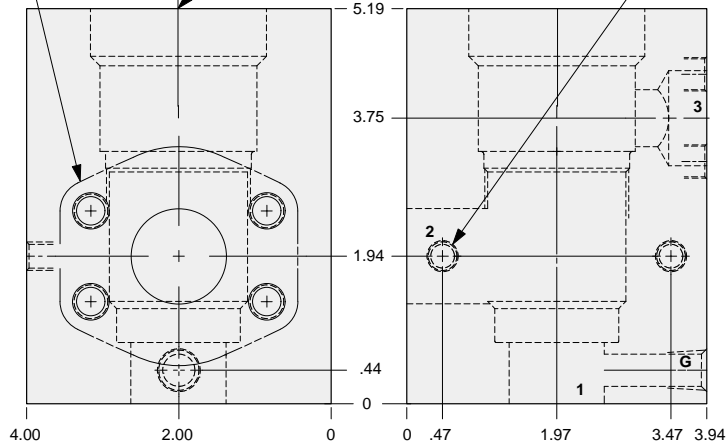

TYPICAL CARTRIDGES USED WITH THIS BODY

- PPJB - *** Page 3.11
PPJC - *** Page 3.13
FRFA - *** Page 6.03

Instructions for ordering complete cartridge and body assemblies. Page v

Pressure ratings, material specifications. Page 11.02

SAE Specifications Page 11.03

Mounting Hole Dimensions	Gage Port	ALUMINUM		DUCTILE IRON	
		Part Number	List Price	Part Number	List Price
Inch	.25 NPTF	KEQ		KEQ/S	
Metric	.25 BSPP	KEQ/M		KEQ/T	

S4
T19A

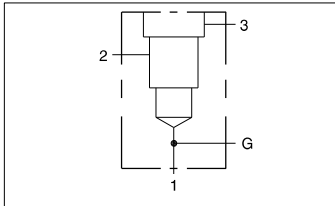

90 degree 1.25" SAE Code 62 flange port body with high capacity port 3 and gage port.

Mounting Holes:
(opposite side)
Inch: .375-16 UNC-2B
x .62 deep.
Metric: M10 x 1.50-6H
x .62 deep.
2 places.

1.25" SAE Code 62
4-Bolt Flange Pattern
3 places.

T-19A Cavity
Locating Shoulder
Depth 2.00

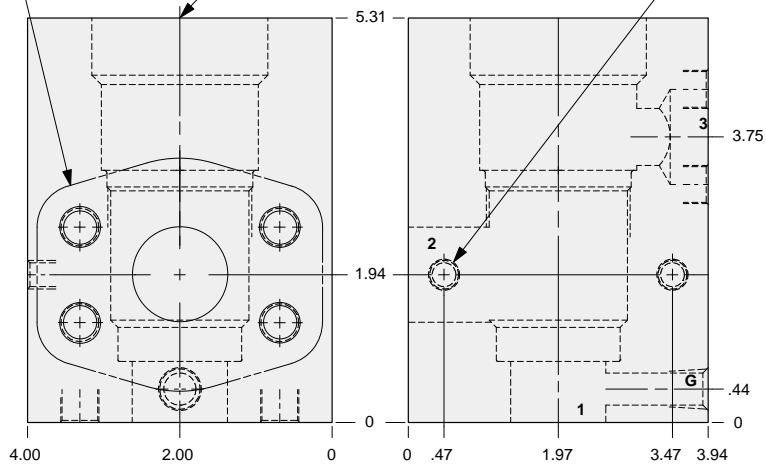

TYPICAL CARTRIDGES USED WITH THIS BODY

- PPJB - *** Page 3.11
PPJC - *** Page 3.13
FRFA - *** Page 6.03

Instructions for ordering complete cartridge and body assemblies. Page v

Pressure ratings, material specifications. Page 11.02

SAE Specifications Page 11.03

Mounting Hole Dimensions	Gage Port	ALUMINUM		DUCTILE IRON	
		Part Number	List Price	Part Number	List Price
Inch	.25 NPTF	KE5		KE5/S	
Metric	.25 BSPP	KE5/M		KE5/T	



LINE MOUNT BODIES

- Aluminum rated to 3000 psi.
- Ductile Iron rated to 5000 psi.

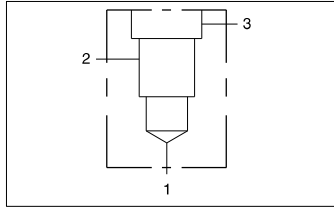

90 degree 1.50" SAE Code 61 flange port body.

1.50" SAE Code 61
4-Bolt Flange Pattern
2 places.

T-19A Cavity
Locating Shoulder
Depth 1.16

Mounting Holes:
(opposite side)
Inch: .375-16 UNC-2B
x .62 deep.
Metric: M10 x 1.50-6H
x .62 deep.
2 places.

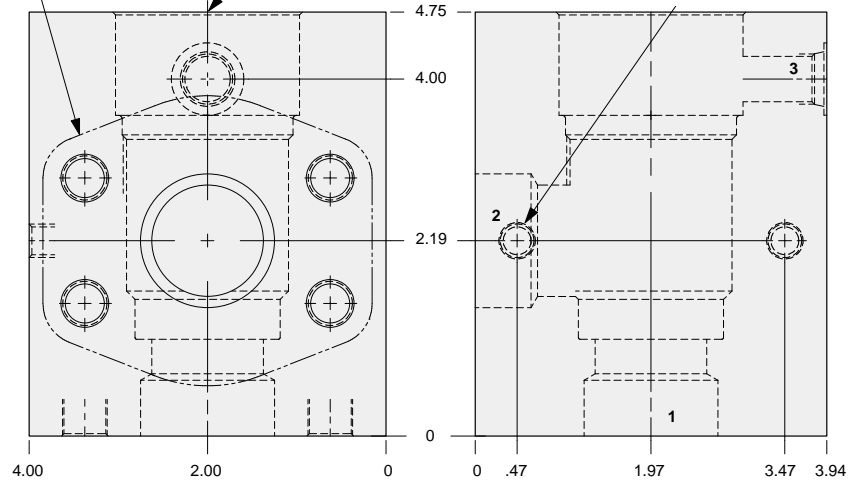

TYPICAL CARTRIDGES USED WITH THIS BODY

RVIA - ***	Page 1.19
RSJC - ***	Page 2.07
SQJB - ***	Page 2.09
RSJE - ***	Page 2.11
SCIA - ***	Page 2.13
PBJB - ***	Page 3.07
PBJC - ***	Page 3.09
CBIA - ***	Page 4.11
CBIG - ***	Page 4.13
CBIH - ***	Page 4.15
CKIB - ***	Page 4.17
LOJC - ***	Page 9.09
LKJC - ***	Page 9.11
LPJC - ***	Page 9.13
LRJC - ***	Page 9.15
COJA - ***	Page 10.13

Instructions for ordering complete cartridge and body assemblies. Page v

Pressure ratings, material specifications. Page 11.02

SAE Specifications Page 11.03

Mounting Hole Dimensions	Port 3	ALUMINUM		DUCTILE IRON	
		Part Number	List Price	Part Number	List Price
Inch	SAE-6	KCR		KCR/S	
Metric	.25 BSPP	KCR/M		KCR/T	

S4
T19A

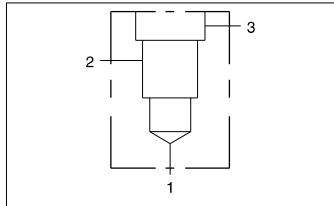

90 degree 1.50" SAE Code 62 flange port body.

1.50" SAE Code 62
4-Bolt Flange Pattern
2 places.

T-19A Cavity
Locating Shoulder
Depth 1.16

Mounting Holes:
(opposite side)
Inch: .375-16 UNC-2B
x .62 deep.
Metric: M10 x 1.50-6H
x .62 deep.
2 places.

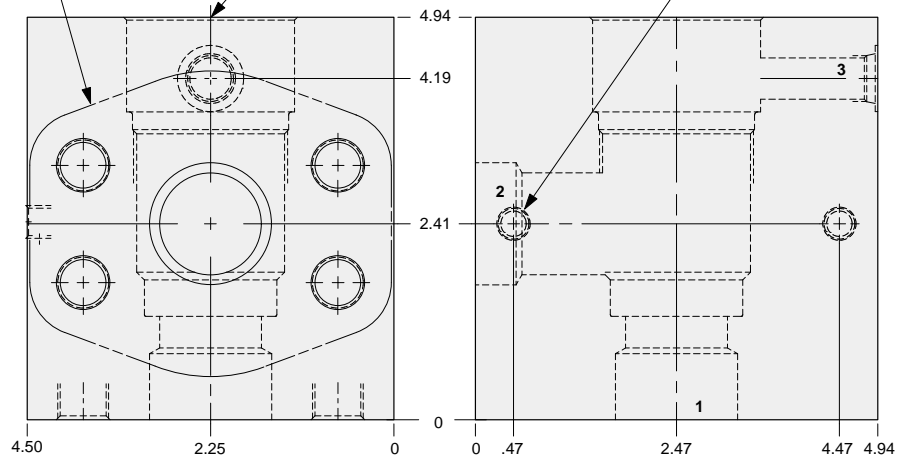

TYPICAL CARTRIDGES USED WITH THIS BODY

RVIA - ***	Page 1.19
RSJC - ***	Page 2.07
SQJB - ***	Page 2.09
RSJE - ***	Page 2.11
SCIA - ***	Page 2.13
PBJB - ***	Page 3.07
PBJC - ***	Page 3.09
CBIA - ***	Page 4.11
CBIG - ***	Page 4.13
CBIH - ***	Page 4.15
CKIB - ***	Page 4.17
LOJC - ***	Page 9.09
LKJC - ***	Page 9.11
LPJC - ***	Page 9.13
LRJC - ***	Page 9.15
COJA - ***	Page 10.13

Instructions for ordering complete cartridge and body assemblies. Page v

Pressure ratings, material specifications. Page 11.02

SAE Specifications Page 11.03

Mounting Hole Dimensions	Port 3	ALUMINUM		DUCTILE IRON	
		Part Number	List Price	Part Number	List Price
Inch	SAE-6	KC6		KC6/S	
Metric	.25 BSPP	KC6/M		KC6/T	



LINE MOUNT BODIES



- Aluminum rated to 3000 psi.
- Ductile Iron rated to 5000 psi.

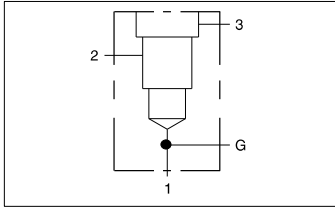

90 degree 1.50" SAE Code 61 flange port body with gage port.

1.50" SAE Code 61
4-Bolt Flange Pattern
2 places.

T-19A Cavity
Locating Shoulder
Depth 1.16

Mounting Holes:
(opposite side)
Inch: .375-16 UNC-2B
x .62 deep.
Metric: M10 x 1.50-6H
x .62 deep.
2 places.

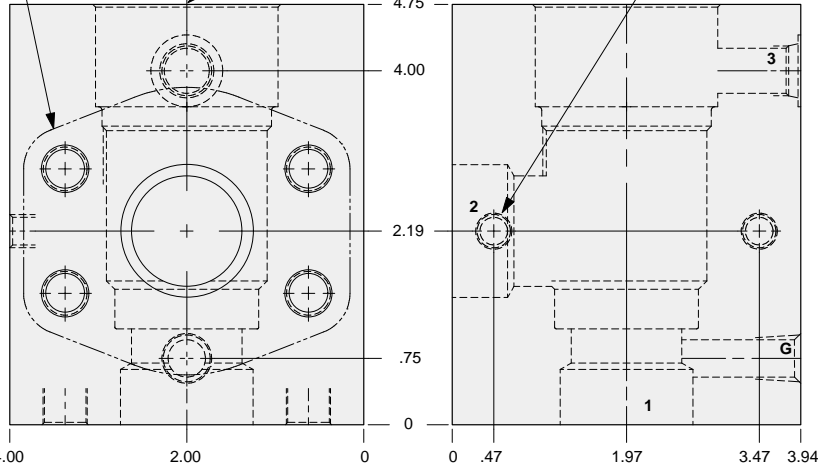

TYPICAL CARTRIDGES USED WITH THIS BODY

RVIA - ***	Page 1.19
RSJC - ***	Page 2.07
SQJB - ***	Page 2.09
RSJE - ***	Page 2.11
SCIA - ***	Page 2.13
PBJB - ***	Page 3.07
PBJC - ***	Page 3.09
CBIA - ***	Page 4.11
CBIG - ***	Page 4.13
CBIH - ***	Page 4.15
CKIB - ***	Page 4.17
LOJC - ***	Page 9.09
LKJC - ***	Page 9.11
LPJC - ***	Page 9.13
LRJC - ***	Page 9.15
COJA - ***	Page 10.13

Instructions for ordering complete cartridge and body assemblies. Page v

Pressure ratings, material specifications. Page 11.02

SAE Specifications Page 11.03

Mounting Hole Dimensions	Port 3	Gage Port	ALUMINUM		DUCTILE IRON	
			Part Number	List Price	Part Number	List Price
Inch	SAE-6	.25 NPTF	KFR		KFR/S	
Metric	.25 BSPP	.25 BSPP	KFR/M		KFR/T	

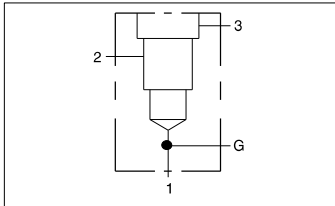

90 degree 1.50" SAE Code 62 flange port body with gage port.

1.50" SAE Code 62
4-Bolt Flange Pattern
2 places.

T-19A Cavity
Locating Shoulder
Depth 1.16

Mounting Holes:
(opposite side)
Inch: .375-16 UNC-2B
x .62 deep.
Metric: M10 x 1.50-6H
x .62 deep.
2 places.

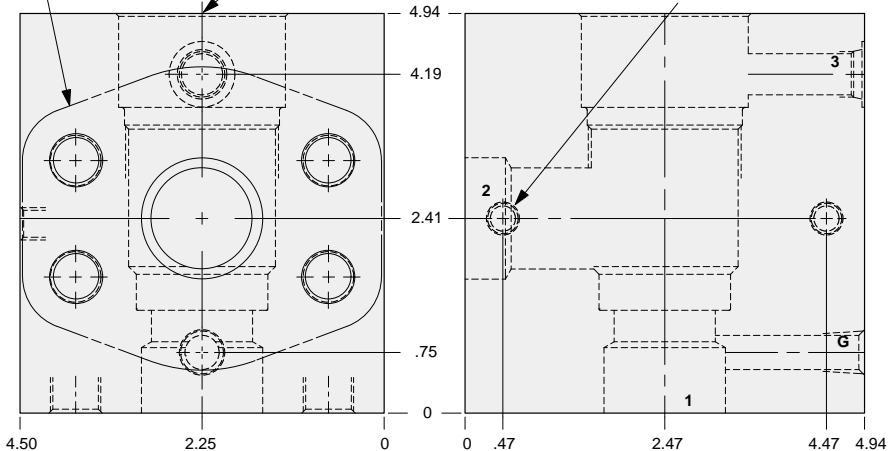

TYPICAL CARTRIDGES USED WITH THIS BODY

RVIA - ***	Page 1.19
RSJC - ***	Page 2.07
SQJB - ***	Page 2.09
RSJE - ***	Page 2.11
SCIA - ***	Page 2.13
PBJB - ***	Page 3.07
PBJC - ***	Page 3.09
CBIA - ***	Page 4.11
CBIG - ***	Page 4.13
CBIH - ***	Page 4.15
CKIB - ***	Page 4.17
LOJC - ***	Page 9.09
LKJC - ***	Page 9.11
LPJC - ***	Page 9.13
LRJC - ***	Page 9.15
COJA - ***	Page 10.13

Instructions for ordering complete cartridge and body assemblies. Page v

Pressure ratings, material specifications. Page 11.02

SAE Specifications Page 11.03

Mounting Hole Dimensions	Port 3	Gage Port	ALUMINUM		DUCTILE IRON	
			Part Number	List Price	Part Number	List Price
Inch	SAE-6	.25 NPTF	KF6		KF6/S	
Metric	.25 BSPP	.25 BSPP	KF6/M		KF6/T	



LINE MOUNT BODIES



- Aluminum rated to 3000 psi.
- Ductile Iron rated to 5000 psi.

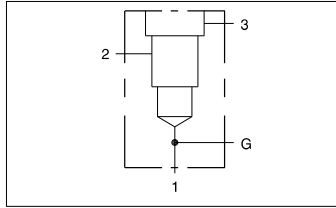

90 degree 1.50" SAE Code 61 flange port body with high capacity port 3 and gage port.

1.50" SAE Code 61
4-Bolt Flange Pattern
3 places.

T-19A Cavity
Locating Shoulder
Depth 2.06

Mounting Holes:
(opposite side)
Inch: .375-16 UNC-2B
x .62 deep.
Metric: M10 x 1.50-6H
x .62 deep.
2 places.

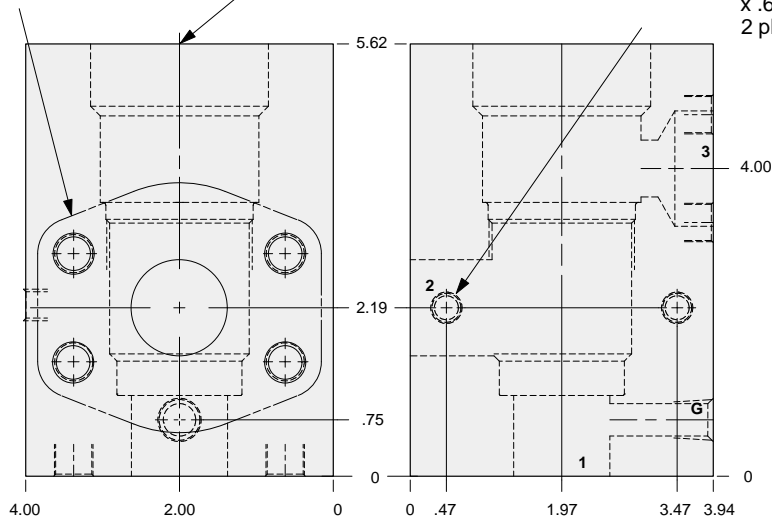

TYPICAL CARTRIDGES USED WITH THIS BODY

PPJB - *** Page 3.11
PPJC - *** Page 3.13
FRFA - *** Page 6.03

Instructions for ordering
complete cartridge and body
assemblies. Page v

Pressure ratings, material
specifications. Page 11.02

SAE Specifications Page 11.03

Mounting Hole Dimensions	Gage Port	ALUMINUM		DUCTILE IRON	
		Part Number	List Price	Part Number	List Price
Inch	.25 NPTF	KER		KER/S	
Metric	.25 BSPP	KER/M		KER/T	

S4
T19A

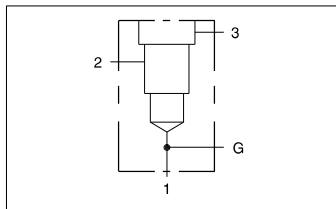

90 degree 1.50" SAE Code 62 flange port body with high capacity port 3 and gage port.

1.50" SAE Code 62
4-Bolt Flange Pattern
3 places.

T-19A Cavity
Locating Shoulder
Depth 2.31

Mounting Holes:
(opposite side)
Inch: .375-16 UNC-2B
x .62 deep.
Metric: M10 x 1.50-6H
x .62 deep.
2 places.

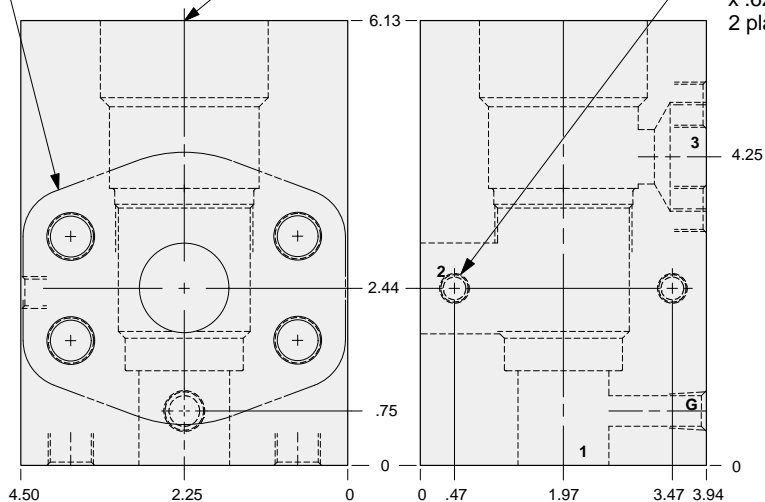

TYPICAL CARTRIDGES USED WITH THIS BODY

PPJB - *** Page 3.11
PPJC - *** Page 3.13
FRFA - *** Page 6.03

Instructions for ordering
complete cartridge and body
assemblies. Page v

Pressure ratings, material
specifications. Page 11.02

SAE Specifications Page 11.03

Mounting Hole Dimensions	Gage Port	ALUMINUM		DUCTILE IRON	
		Part Number	List Price	Part Number	List Price
Inch	.25 NPTF	KE6		KE6/S	
Metric	.25 BSPP	KE6/M		KE6/T	



LINE MOUNT BODIES



- Aluminum rated to 3000 psi.
- Ductile Iron rated to 5000 psi.

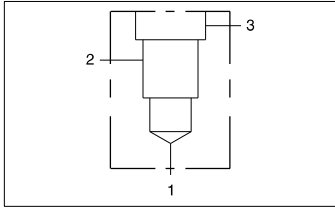

90 degree 2.00" SAE Code 61 flange port body.

2.00" SAE Code 61
4-Bolt Flange Pattern
2 places.

T-19A Cavity
Locating Shoulder
Depth 1.16

Mounting Holes:
(opposite side)
Inch: .375-16 UNC-2B
x .62 deep.
Metric: M10 x 1.50-6H
x .62 deep.
2 places.

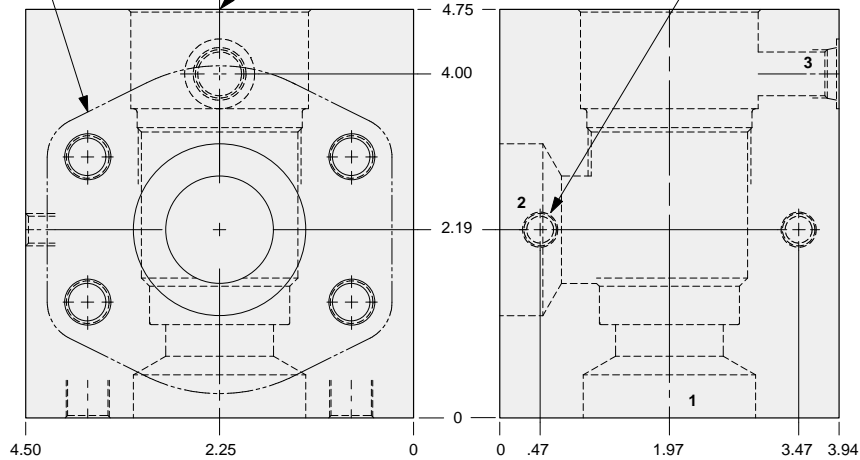

Mounting Hole Dimensions	Port 3	ALUMINUM		DUCTILE IRON	
		Part Number	List Price	Part Number	List Price
Inch	SAE-6	KCS		KCS/S	
Metric	.25 BSPP	KCS/M		KCS/T	

TYPICAL CARTRIDGES USED WITH THIS BODY

RVIA - ***	Page 1.19
RSJC - ***	Page 2.07
SQJB - ***	Page 2.09
RSJE - ***	Page 2.11
SCIA - ***	Page 2.13
PBJB - ***	Page 3.07
PBJC - ***	Page 3.09
CBIA - ***	Page 4.11
CBIG - ***	Page 4.13
CBIH - ***	Page 4.15
CKIB - ***	Page 4.17
LOJC - ***	Page 9.09
LKJC - ***	Page 9.11
LPJC - ***	Page 9.13
LRJC - ***	Page 9.15
COJA - ***	Page 10.13

Instructions for ordering complete cartridge and body assemblies. Page v

Pressure ratings, material specifications. Page 11.02

SAE Specifications Page 11.03

S4
T19A

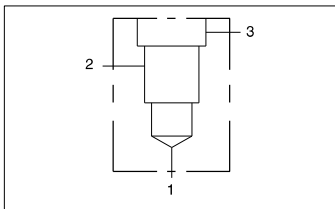

90 degree 2.00" SAE Code 62 flange port body.

2.00" SAE Code 62
4-Bolt Flange Pattern
2 places.

T-19A Cavity
Locating Shoulder
Depth 1.16

Mounting Holes:
(opposite side)
Inch: .375-16 UNC-2B
x .62 deep.
Metric: M10 x 1.50-6H
x .62 deep.
2 places.

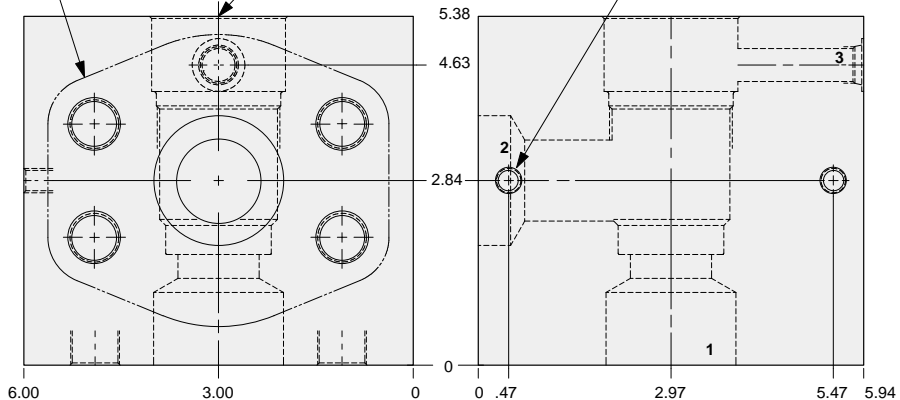

Mounting Hole Dimensions	Port 3	ALUMINUM		DUCTILE IRON	
		Part Number	List Price	Part Number	List Price
Inch	SAE-6	KC8		KC8/S	
Metric	.25 BSPP	KC8/M		KC8/T	

TYPICAL CARTRIDGES USED WITH THIS BODY

RVIA - ***	Page 1.19
RSJC - ***	Page 2.07
SQJB - ***	Page 2.09
RSJE - ***	Page 2.11
SCIA - ***	Page 2.13
PBJB - ***	Page 3.07
PBJC - ***	Page 3.09
CBIA - ***	Page 4.11
CBIG - ***	Page 4.13
CBIH - ***	Page 4.15
CKIB - ***	Page 4.17
LOJC - ***	Page 9.09
LKJC - ***	Page 9.11
LPJC - ***	Page 9.13
LRJC - ***	Page 9.15
COJA - ***	Page 10.13

Instructions for ordering complete cartridge and body assemblies. Page v

Pressure ratings, material specifications. Page 11.02

SAE Specifications Page 11.03



LINE MOUNT BODIES



- Aluminum rated to 3000 psi.
- Ductile Iron rated to 5000 psi.

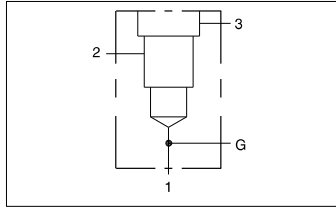

90 degree 2.00" SAE Code 61 flange port body with gage port.

2.00" SAE Code 61
4-Bolt Flange Pattern
2 places.

T-19A Cavity
Locating Shoulder
Depth 1.16

Mounting Holes:
(opposite side)
Inch: .375-16 UNC-2B
x .62 deep.
Metric: M10 x 1.50-6H
x .62 deep.
2 places.

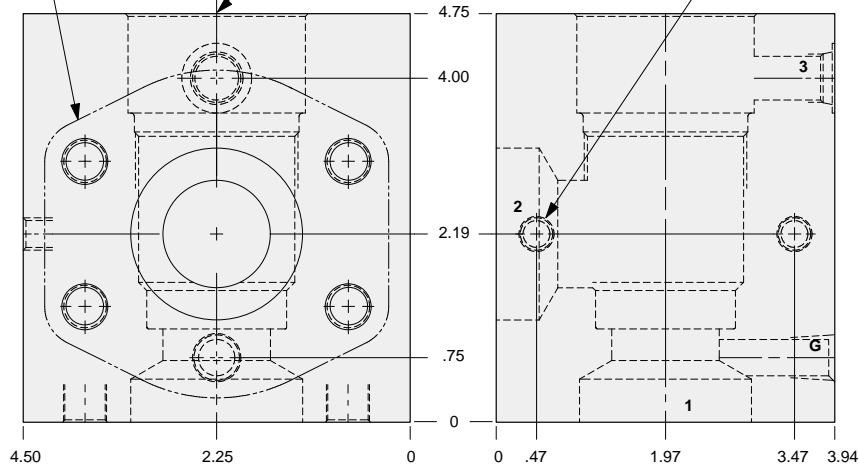

TYPICAL CARTRIDGES USED WITH THIS BODY

RVIA - ***	Page 1.19
RSJC - ***	Page 2.07
SQJB - ***	Page 2.09
RSJE - ***	Page 2.11
SCIA - ***	Page 2.13
PBJB - ***	Page 3.07
PBJC - ***	Page 3.09
CBIA - ***	Page 4.11
CBIG - ***	Page 4.13
CBIH - ***	Page 4.15
CKIB - ***	Page 4.17
LOJC - ***	Page 9.09
LKJC - ***	Page 9.11
LPJC - ***	Page 9.13
LRJC - ***	Page 9.15
COJA - ***	Page 10.13

Instructions for ordering complete cartridge and body assemblies. Page v

Pressure ratings, material specifications. Page 11.02

SAE Specifications Page 11.03

Mounting Hole Dimensions	Port 3	Gage Port	ALUMINUM		DUCTILE IRON	
			Part Number	List Price	Part Number	List Price
Inch	SAE-6	.25 NPTF	KFS		KFS/S	
Metric	.25 BSPP	.25 BSPP	KFS/M		KFS/T	

S4
T19A

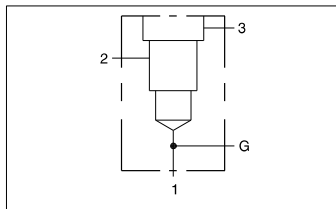

90 degree 2.00" SAE Code 62 flange port body with gage port.

2.00" SAE Code 62
4-Bolt Flange Pattern
2 places.

T-19A Cavity
Locating Shoulder
Depth 1.16

Mounting Holes:
(opposite side)
Inch: .375-16 UNC-2B
x .62 deep.
Metric: M10 x 1.50-6H
x .62 deep.
2 places.

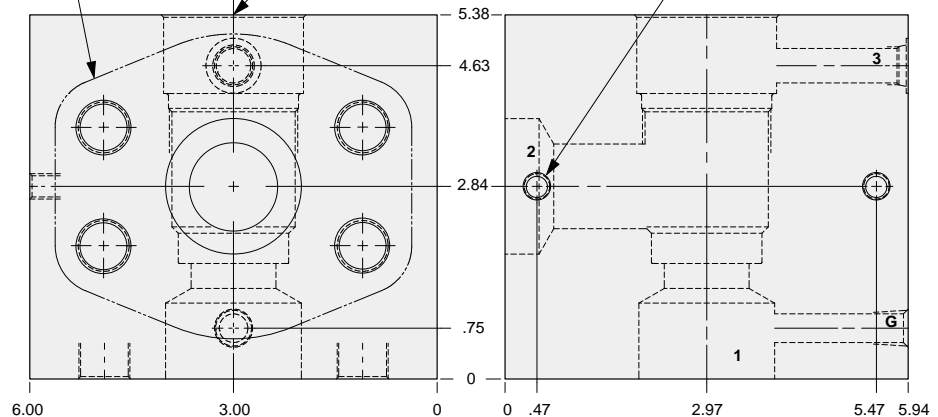

TYPICAL CARTRIDGES USED WITH THIS BODY

RVIA - ***	Page 1.19
RSJC - ***	Page 2.07
SQJB - ***	Page 2.09
RSJE - ***	Page 2.11
SCIA - ***	Page 2.13
PBJB - ***	Page 3.07
PBJC - ***	Page 3.09
CBIA - ***	Page 4.11
CBIG - ***	Page 4.13
CBIH - ***	Page 4.15
CKIB - ***	Page 4.17
LOJC - ***	Page 9.09
LKJC - ***	Page 9.11
LPJC - ***	Page 9.13
LRJC - ***	Page 9.15
COFA - ***	Page 10.12
COJA - ***	Page 10.13

Instructions for ordering complete cartridge and body assemblies. Page v

Pressure ratings, material specifications. Page 11.02

SAE Specifications Page 11.03

Mounting Hole Dimensions	Port 3	Gage Port	ALUMINUM		DUCTILE IRON	
			Part Number	List Price	Part Number	List Price
Inch	SAE-6	.25 NPTF	KF8		KF8/S	
Metric	.25 BSPP	.25 BSPP	KF8/M		KF8/T	



LINE MOUNT BODIES



- Aluminum rated to 3000 psi.
- Ductile Iron rated to 5000 psi.

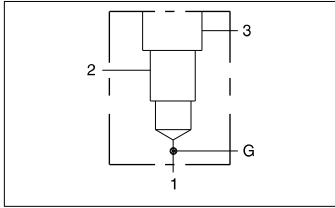

90 degree 2.00" SAE Code 61 flange port body with high capacity port 3 and gage port.

2.00" SAE Code 61
4-Bolt Flange Pattern
2 places.

T-19A Cavity
Locating Shoulder
Depth 2.06

Mounting Holes:
(opposite side)
Inch: .375-16 UNC-2B
x .62 deep.
Metric: M10 x 1.50-6H
x .75 deep.
2 places.

1.50" SAE Code 61
4-Bolt Flange Pattern

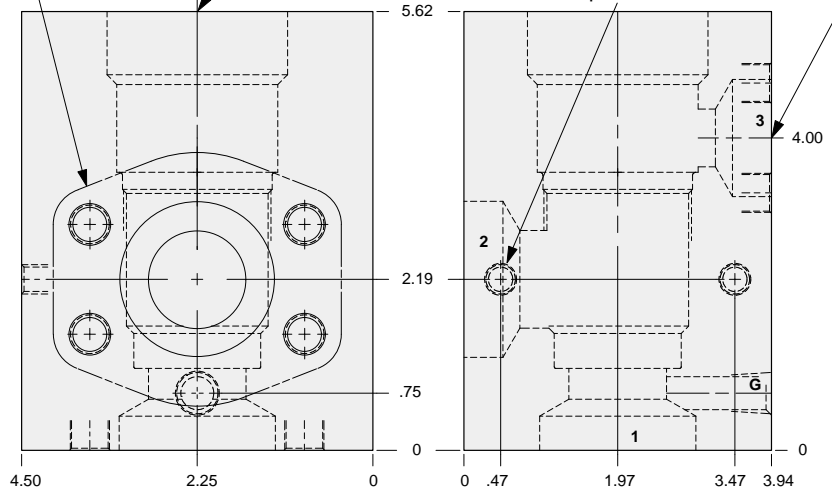

Mounting Hole Dimensions	Port 3 SAE Code 61	Gage Port	ALUMINUM		DUCTILE IRON	
			Part Number	List Price	Part Number	List Price
Inch	1.50"	.25 NPTF	KES		KES/S	
Metric	1.50"	.25 BSPP	KES/M		KES/T	

TYPICAL CARTRIDGES USED WITH THIS BODY

PPJB - *** Page 3.11
PPJC - *** Page 3.13
FRFA - *** Page 6.03

Instructions for ordering complete cartridge and body assemblies. Page v

Pressure ratings, material specifications. Page 11.02

SAE Specifications Page 11.03

S4
T19A

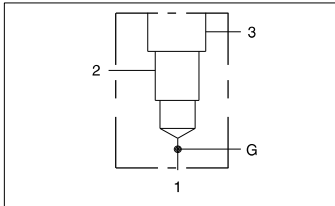

90 degree 2.00" SAE Code 62 flange port body with high capacity port 3 and gage port.

2.00" SAE Code 62
4-Bolt Flange Pattern
2 places.

T-19A Cavity
Locating Shoulder
Depth 2.31

Mounting Holes:
(opposite side)
Inch: .375-16 UNC-2B
x .62 deep.
Metric: M10 x 1.50-6H
x .62 deep.
2 places.

1.50" SAE Code 62
4-Bolt Flange Pattern

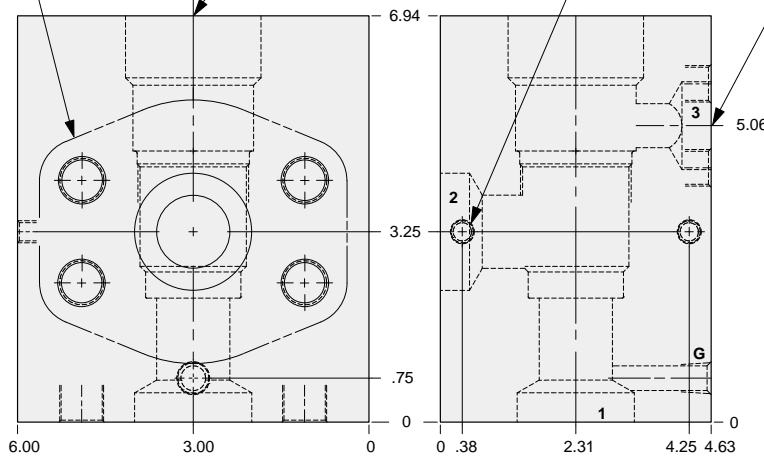

Mounting Hole Dimensions	Port 3 SAE Code 62	Gage Port	ALUMINUM		DUCTILE IRON	
			Part Number	List Price	Part Number	List Price
Inch	1.50"	.25 NPTF	KE8		KE8/S	
Metric	1.50"	.25 BSPP	KE8/M		KE8/T	

TYPICAL CARTRIDGES USED WITH THIS BODY

PPJB - *** Page 3.11
PPJC - *** Page 3.13
FRFA - *** Page 6.03

Instructions for ordering complete cartridge and body assemblies. Page v

Pressure ratings, material specifications. Page 11.02

SAE Specifications Page 11.03



LINE MOUNT BODIES



- Aluminum rated to 3000 psi.
- Ductile Iron rated to 5000 psi.

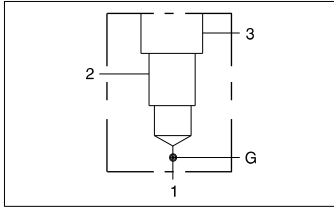

Through port 1.00" SAE Code 61 flange port body with gage port.

1.00" SAE Code 61
4-Bolt Flange Pattern
3 places.

T-19A Cavity
Locating Shoulder
Depth 1.16

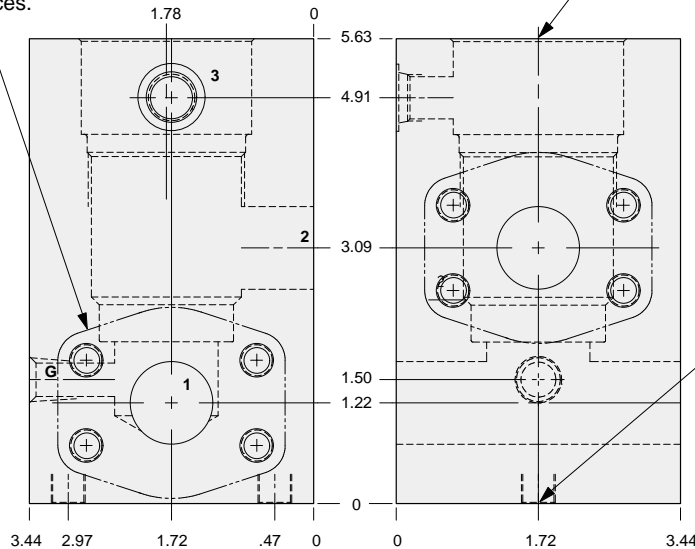

Mounting Holes:
Inch: .375-16 UNC-2B
x .62 deep.
Metric: M10 x 1.50-6H
x .62 deep.
2 places.

TYPICAL CARTRIDGES USED WITH THIS BODY

RVIA - ***	Page 1.19
RSJC - ***	Page 2.07
SQJB - ***	Page 2.09
RSJE - ***	Page 2.11
SCIA - ***	Page 2.13
PBJB - ***	Page 3.07
PBJC - ***	Page 3.09

Instructions for ordering complete cartridge and body assemblies. Page v

Pressure ratings, material specifications. Page 11.02

SAE Specifications Page 11.03

Mounting Hole Dimensions	Port 3	Gage Port	ALUMINUM		DUCTILE IRON	
			Part Number	List Price	Part Number	List Price
Inch	SAE-6	.25 NPTF	KHP		KHP/S	
Metric	.25 BSPP	.25 BSPP	KHP/M		KHP/T	

S4
T19A

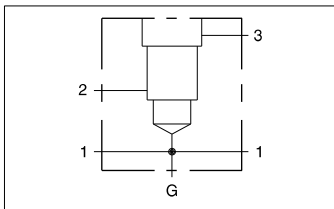

Through port 1.00" SAE Code 62 flange port body with gage port.

1.00" SAE Code 62
4-Bolt Flange Pattern
3 places.

T-19A Cavity
Locating Shoulder
Depth 1.16

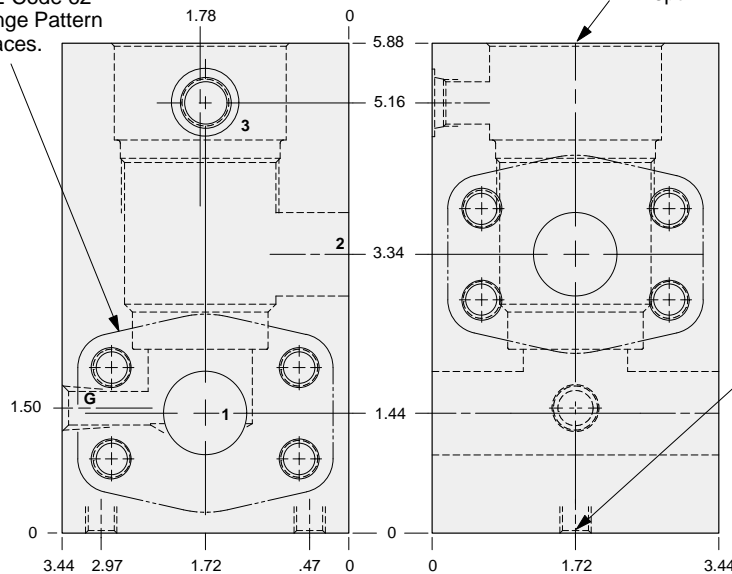

Mounting Holes:
Inch: .375-16 UNC-2B
x .62 deep.
Metric: M10 x 1.50-6H
x .62 deep.
2 places.

TYPICAL CARTRIDGES USED WITH THIS BODY

RVIA - ***	Page 1.19
RSJC - ***	Page 2.07
SQJB - ***	Page 2.09
RSJE - ***	Page 2.11
SCIA - ***	Page 2.13
PBJB - ***	Page 3.07
PBJC - ***	Page 3.09

Instructions for ordering complete cartridge and body assemblies. Page v

Pressure ratings, material specifications. Page 11.02

SAE Specifications Page 11.03

Mounting Hole Dimensions	Port 3	Gage Port	ALUMINUM		DUCTILE IRON	
			Part Number	List Price	Part Number	List Price
Inch	SAE-6	.25 NPTF	KH4		KH4/S	
Metric	.25 BSPP	.25 BSPP	KH4/M		KH4/T	



LINE MOUNT BODIES



- Aluminum rated to 3000 psi.
- Ductile Iron rated to 5000 psi.

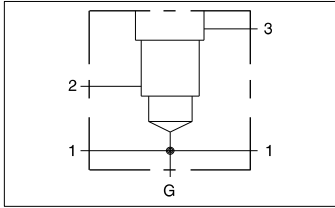

Through port 1.25" SAE Code 61 flange port body with gage port.

1.25" SAE Code 61
4-Bolt Flange Pattern
3 places.

T-19A Cavity
Locating Shoulder
Depth 1.16

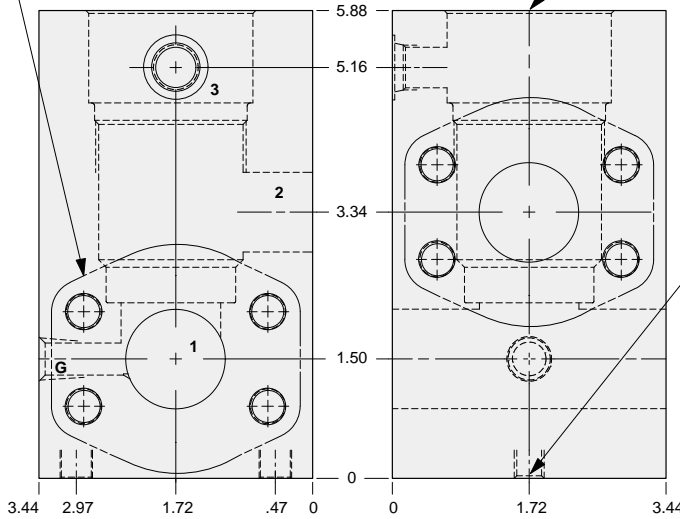

Mounting Holes:
Inch: .375-16 UNC-2B
x .62 deep.
Metric: M10 x 1.50-6H
x .62 deep.
2 places.

TYPICAL CARTRIDGES USED WITH THIS BODY

RVIA - ***	Page 1.19
RSJC - ***	Page 2.07
SQJB - ***	Page 2.09
RSJE - ***	Page 2.11
SCIA - ***	Page 2.13
PBJB - ***	Page 3.07
PBJC - ***	Page 3.09

Instructions for ordering complete cartridge and body assemblies. Page v

Pressure ratings, material specifications. Page 11.02

SAE Specifications Page 11.03

Mounting Hole Dimensions	Port 3	Gage Port	ALUMINUM		DUCTILE IRON	
			Part Number	List Price	Part Number	List Price
Inch	SAE-6	.25 NPTF	KHQ		KHQ/S	
Metric	.25 BSPP	.25 BSPP	KHQ/M		KHQ/T	

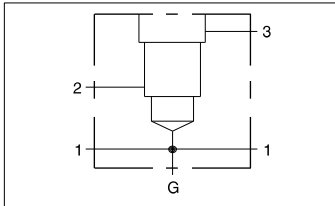

Through port 1.25" SAE Code 62 flange port body with gage port.

1.25" SAE Code 62
4-Bolt Flange Pattern
3 places.

T-19A Cavity
Locating Shoulder
Depth 1.16

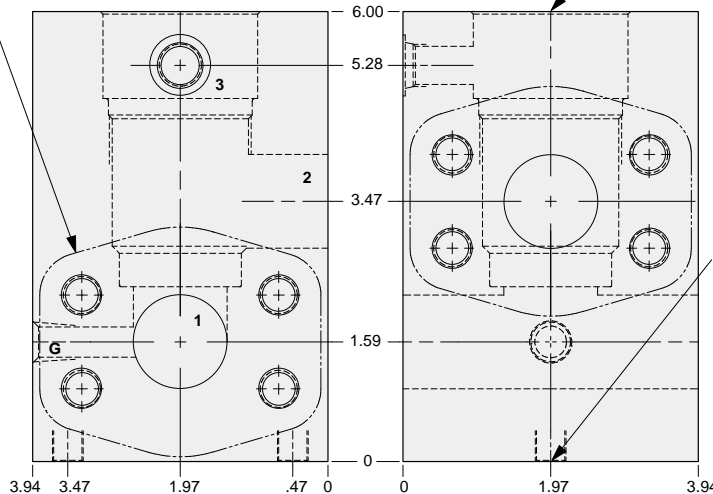

Mounting Holes:
Inch: .375-16 UNC-2B
x .62 deep.
Metric: M10 x 1.50-6H
x .62 deep.
2 places.

TYPICAL CARTRIDGES USED WITH THIS BODY

RVIA - ***	Page 1.19
RSJC - ***	Page 2.07
SQJB - ***	Page 2.09
RSJE - ***	Page 2.11
SCIA - ***	Page 2.13
PBJB - ***	Page 3.07
PBJC - ***	Page 3.09

Instructions for ordering complete cartridge and body assemblies. Page v

Pressure ratings, material specifications. Page 11.02

SAE Specifications Page 11.03

Mounting Hole Dimensions	Port 3	Gage Port	ALUMINUM		DUCTILE IRON	
			Part Number	List Price	Part Number	List Price
Inch	SAE-6	.25 NPTF	KH5		KH5/S	
Metric	.25 BSPP	.25 BSPP	KH5/M		KH5/T	



LINE MOUNT BODIES



- Aluminum rated to 3000 psi.
- Ductile Iron rated to 5000 psi.

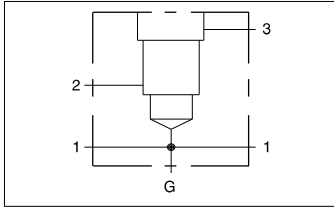

Through port 1.50" SAE Code 61 flange port body with gage port.

1.50" SAE Code 61
4-Bolt Flange Pattern
3 places.

T-19A Cavity
Locating Shoulder
Depth 1.16

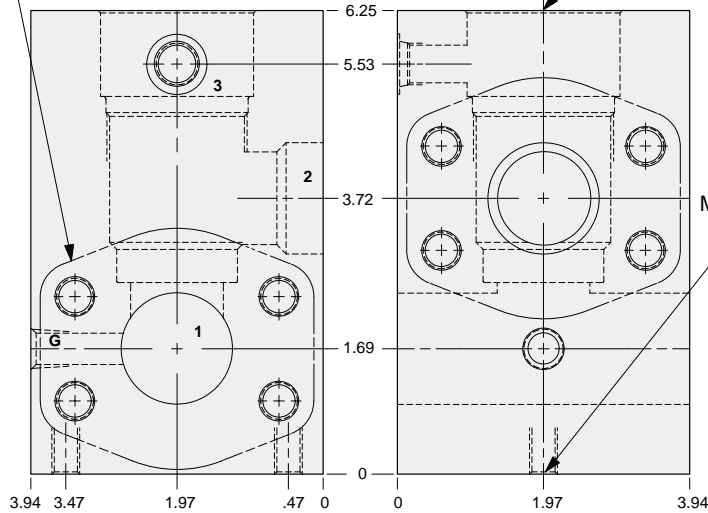

Mounting Holes:
Inch: .375-16 UNC-2B
x .62 deep.
Metric: M10 x 1.50-6H
x .62 deep.
2 places.

TYPICAL CARTRIDGES USED WITH THIS BODY

RVIA - ***	Page 1.19
RSJC - ***	Page 2.07
SQJB - ***	Page 2.09
RSJE - ***	Page 2.11
SCIA - ***	Page 2.13
PBJB - ***	Page 3.07
PBJC - ***	Page 3.09

Instructions for ordering complete cartridge and body assemblies. Page v

Pressure ratings, material specifications. Page 11.02

SAE Specifications Page 11.03

Mounting Hole Dimensions	Port 3	Gage Port	ALUMINUM		DUCTILE IRON	
			Part Number	List Price	Part Number	List Price
Inch	SAE-6	.25 NPTF	KHR		KHR/S	
Metric	.25 BSPP	.25 BSPP	KHR/M		KHR/T	

S4
T19A

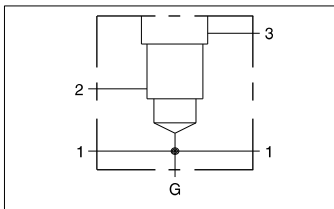

Through port 1.50" SAE Code 62 flange port body with gage port.

1.50" SAE Code 62
4-Bolt Flange Pattern
3 places.

T-19A Cavity
Locating Shoulder
Depth 1.16

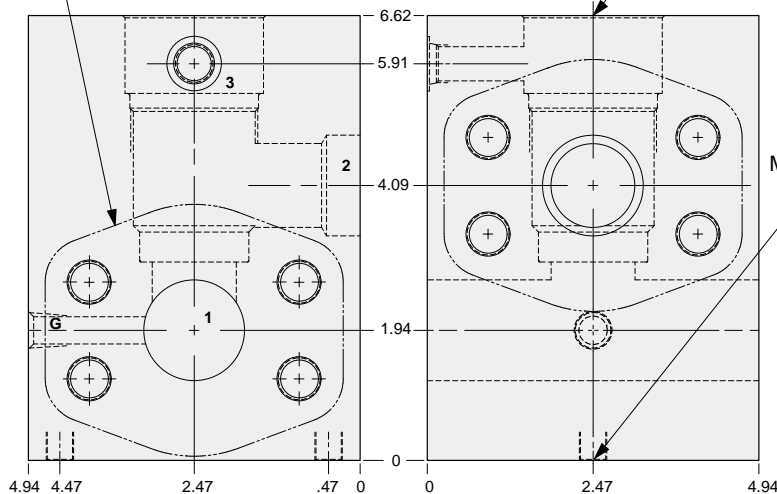

Mounting Holes:
Inch: .375-16 UNC-2B
x .62 deep.
Metric: M10 x 1.50-6H
x .62 deep.
2 places.

TYPICAL CARTRIDGES USED WITH THIS BODY

RVIA - ***	Page 1.19
RSJC - ***	Page 2.07
SQJB - ***	Page 2.09
RSJE - ***	Page 2.11
SCIA - ***	Page 2.13
PBJB - ***	Page 3.07
PBJC - ***	Page 3.09

Instructions for ordering complete cartridge and body assemblies. Page v

Pressure ratings, material specifications. Page 11.02

SAE Specifications Page 11.03

Mounting Hole Dimensions	Port 3	Gage Port	ALUMINUM		DUCTILE IRON	
			Part Number	List Price	Part Number	List Price
Inch	SAE-6	.25 NPTF	KH6		KH6/S	
Metric	.25 BSPP	.25 BSPP	KH6/M		KH6/T	



LINE MOUNT BODIES



- Aluminum rated to 3000 psi.
- Ductile Iron rated to 5000 psi.

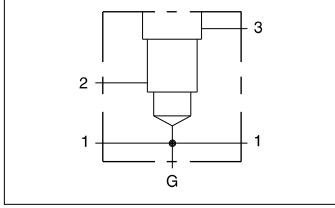

Through port 2.00" SAE Code 61 flange port body with gage port.

2.00" SAE Code 61
4-Bolt Flange Pattern
3 places.

T-19A Cavity
Locating Shoulder
Depth 1.16

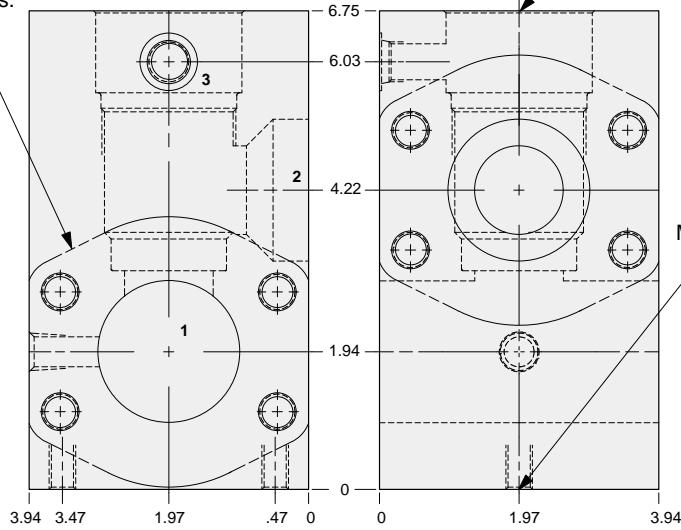

Mounting Holes:
Inch: .375-16 UNC-2B
x .62 deep.
Metric: M10 x 1.50-6H
x .62 deep.
2 places.

TYPICAL CARTRIDGES USED WITH THIS BODY

RVIA - ***	Page 1.19
RSJC - ***	Page 2.07
SQJB - ***	Page 2.09
RSJE - ***	Page 2.11
SCIA - ***	Page 2.13
PBJB - ***	Page 3.07
PBJC - ***	Page 3.09

Instructions for ordering complete cartridge and body assemblies. Page v

Pressure ratings, material specifications. Page 11.02

SAE Specifications Page 11.03

Mounting Hole Dimensions	Port 3	Gage Port	ALUMINUM		DUCTILE IRON	
			Part Number	List Price	Part Number	List Price
Inch	SAE-6	.25 NPTF	KHS		KHS/S	
Metric	.25 BSPP	.25 BSPP	KHS/M		KHS/T	

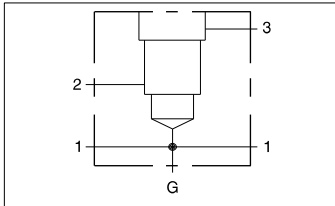

Through port 2.00" SAE Code 62 flange port body with gage port.

2.00" SAE Code 62
4-Bolt Flange Pattern
3 places.

T-19A Cavity
Locating Shoulder
Depth 1.16

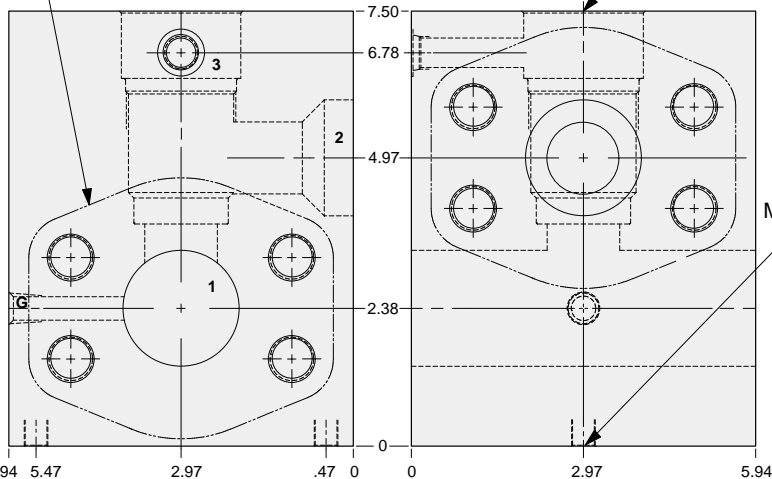

Mounting Holes:
Inch: .375-16 UNC-2B
x .62 deep.
Metric: M10 x 1.50-6H
x .62 deep.
2 places.

TYPICAL CARTRIDGES USED WITH THIS BODY

RVIA - ***	Page 1.19
RSJC - ***	Page 2.07
SQJB - ***	Page 2.09
RSJE - ***	Page 2.11
SCIA - ***	Page 2.13
PBJB - ***	Page 3.07
PBJC - ***	Page 3.09

Instructions for ordering complete cartridge and body assemblies. Page v

Pressure ratings, material specifications. Page 11.02

SAE Specifications Page 11.03

Mounting Hole Dimensions	Port 3	Gage Port	ALUMINUM		DUCTILE IRON	
			Part Number	List Price	Part Number	List Price
Inch	SAE-6	.25 NPTF	KH8		KH8/S	
Metric	.25 BSPP	.25 BSPP	KH8/M		KH8/T	



LINE MOUNT BODIES



- Aluminum rated to 3000 psi.
- Ductile Iron rated to 5000 psi.

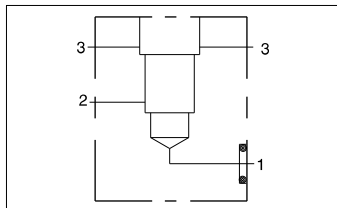

Direct mount 1.25" SAE Code 61 body.

1.25" SAE Code 61
4-Bolt Flange Pattern
2 places.
2 holes tapped
4 holes through

T-19A Cavity
Locating Shoulder
Depth 1.19

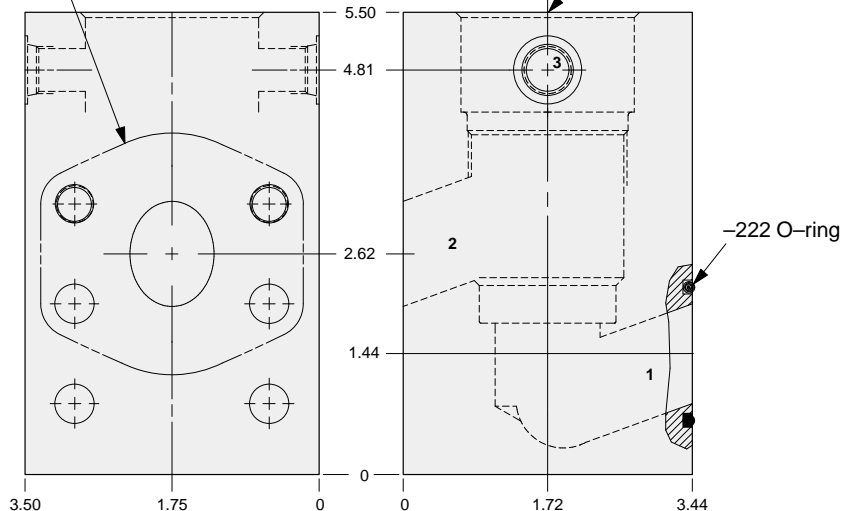

TYPICAL CARTRIDGES USED WITH THIS BODY

RVIA - ***	Page 1.19
RSJC - ***	Page 2.07
SQJB - ***	Page 2.09
RSJE - ***	Page 2.11
SCIA - ***	Page 2.13
CBIA - ***	Page 4.11
CBIG - ***	Page 4.13
CBIH - ***	Page 4.15
CKIB - ***	Page 4.17
LOJC - ***	Page 9.09
LKJC - ***	Page 9.11
LPJC - ***	Page 9.13
LRJC - ***	Page 9.15
COJA - ***	Page 10.13

Cartridge seal type determines O-ring type.

Instructions for ordering complete cartridge and body assemblies. Page v

Pressure ratings, material specifications. Page 11.02

SAE Specifications Page 11.03

Mounting Hole Dimensions	Port 3	ALUMINUM		DUCTILE IRON	
		Part Number	List Price	Part Number	List Price
Inch	SAE-6	ZNX		ZNX/S	
Metric	.25 BSPP	ZNX/M		ZNX/T	

S4
T19A

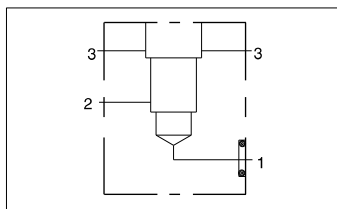

Direct mount 1.25" SAE Code 62 body.

1.25" SAE Code 62
4-Bolt Flange Pattern
2 places.
2 holes tapped
4 holes through

T-19A Cavity
Locating Shoulder
Depth 1.19

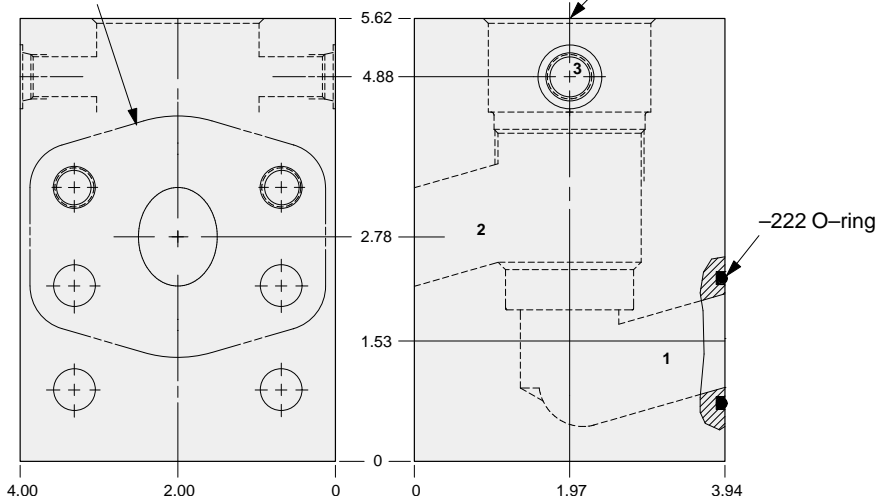

TYPICAL CARTRIDGES USED WITH THIS BODY

RVIA - ***	Page 1.19
RSJC - ***	Page 2.07
SQJB - ***	Page 2.09
RSJE - ***	Page 2.11
SCIA - ***	Page 2.13
CBIA - ***	Page 4.11
CBIG - ***	Page 4.13
CBIH - ***	Page 4.15
CKIB - ***	Page 4.17
LOJC - ***	Page 9.09
LKJC - ***	Page 9.11
LPJC - ***	Page 9.13
LRJC - ***	Page 9.15
COJA - ***	Page 10.13

Cartridge seal type determines O-ring type.

Instructions for ordering complete cartridge and body assemblies. Page v

Pressure ratings, material specifications. Page 11.02

SAE Specifications Page 11.03

Mounting Hole Dimensions	Port 3	ALUMINUM		DUCTILE IRON	
		Part Number	List Price	Part Number	List Price
Inch	SAE-6	ZFD		ZFD/S	
Metric	.25 BSPP	ZFD/M		ZFD/T	



LINE MOUNT BODIES



- Aluminum rated to 3000 psi.
- Ductile Iron rated to 5000 psi.

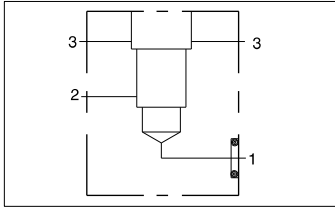

Direct mount 1.50" SAE Code 61 body.

1.50" SAE Code 61
4-Bolt Flange Pattern
2 places.
2 holes tapped
4 holes through

T-19A Cavity
Locating Shoulder
Depth 1.22

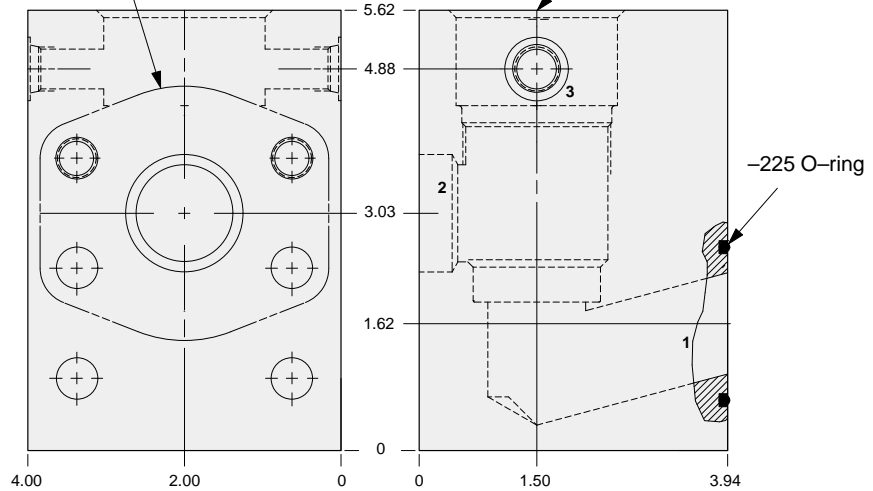

TYPICAL CARTRIDGES USED WITH THIS BODY

RVIA - ***	Page 1.19
RSJC - ***	Page 2.07
SQJB - ***	Page 2.09
RSJE - ***	Page 2.11
SCIA - ***	Page 2.13
CBIA - ***	Page 4.11
CBIG - ***	Page 4.13
CBIH - ***	Page 4.15
CKIB - ***	Page 4.17
LOJC - ***	Page 9.09
LKJC - ***	Page 9.11
LPJC - ***	Page 9.13
LRJC - ***	Page 9.15
COJA - ***	Page 10.13

Cartridge seal type determines O-ring type.

Instructions for ordering complete cartridge and body assemblies. Page v

Pressure ratings, material specifications. Page 11.02

SAE Specifications Page 11.03

Mounting Hole Dimensions	Port 3	ALUMINUM		DUCTILE IRON	
		Part Number	List Price	Part Number	List Price
Inch	SAE-6	ZNY		ZNY/S	
Metric	.25 BSPP	ZNY/M		ZNY/T	

S4
T19A

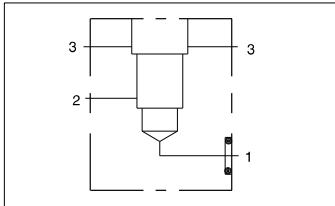

Direct mount 1.50" SAE Code 62 body.

1.50" SAE Code 62
4-Bolt Flange Pattern
2 places.
2 holes tapped
4 holes through

T-19A Cavity
Locating Shoulder
Depth 1.34

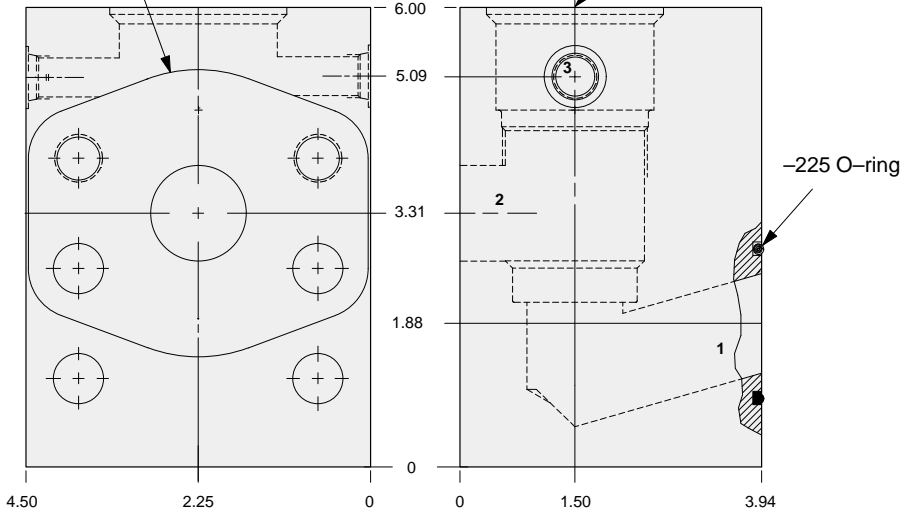

TYPICAL CARTRIDGES USED WITH THIS BODY

RVIA - ***	Page 1.19
RSJC - ***	Page 2.07
SQJB - ***	Page 2.09
RSJE - ***	Page 2.11
SCIA - ***	Page 2.13
CBIA - ***	Page 4.11
CBIG - ***	Page 4.13
CBIH - ***	Page 4.15
CKIB - ***	Page 4.17
LOJC - ***	Page 9.09
LKJC - ***	Page 9.11
LPJC - ***	Page 9.13
LRJC - ***	Page 9.15
COJA - ***	Page 10.13

Cartridge seal type determines O-ring type.

Instructions for ordering complete cartridge and body assemblies. Page v

Pressure ratings, material specifications. Page 11.02

SAE Specifications Page 11.03

Mounting Hole Dimensions	Port 3	ALUMINUM		DUCTILE IRON	
		Part Number	List Price	Part Number	List Price
Inch	SAE-6	ZDQ		ZDQ/S	
Metric	.25 BSPP	ZDQ/M		ZDQ/T	



LINE MOUNT BODIES



- Aluminum rated to 3000 psi.
- Ductile Iron rated to 5000 psi.

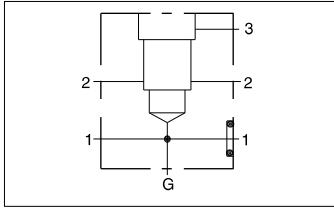

Sandwich mount through port 1.50" SAE Code 61 body with gage port.

1.50" SAE Code 61
4-Bolt Flange Pattern
2 places.

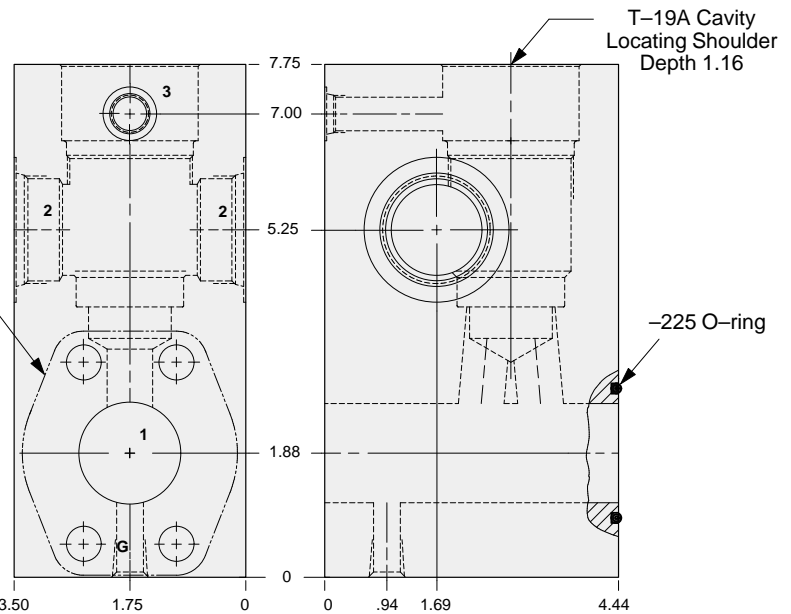

TYPICAL CARTRIDGES USED WITH THIS BODY

- RVIA - *** Page 1.19
- RSJC - *** Page 2.07
- SQJB - *** Page 2.09
- RSJE - *** Page 2.11
- SCIA - *** Page 2.13

Cartridge seal type determines O-ring type.

Instructions for ordering complete cartridge and body assemblies. Page v

Pressure ratings, material specifications. Page 11.02

SAE Specifications Page 11.03

Mounting Hole Dimensions	Port 2	Port 3	Gage Port	ALUMINUM		DUCTILE IRON	
				Part Number	List Price	Part Number	List Price
Inch	1.25 NPTF	.25 NPTF	.25 NPTF	ZMW		ZMW/S	
Inch	SAE-20	SAE-6	.25 NPTF	ZMX		ZMX/S	
Metric	1.25 BSPP	.25 BSPP	.25 BSPP	ZMY/M		ZMY/T	

S4
T19A

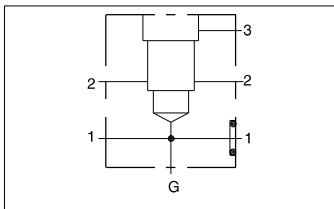

Sandwich mount through port 1.50" SAE Code 62 body with gage port.

1.50" SAE Code 62
4-Bolt Flange Pattern
2 places.

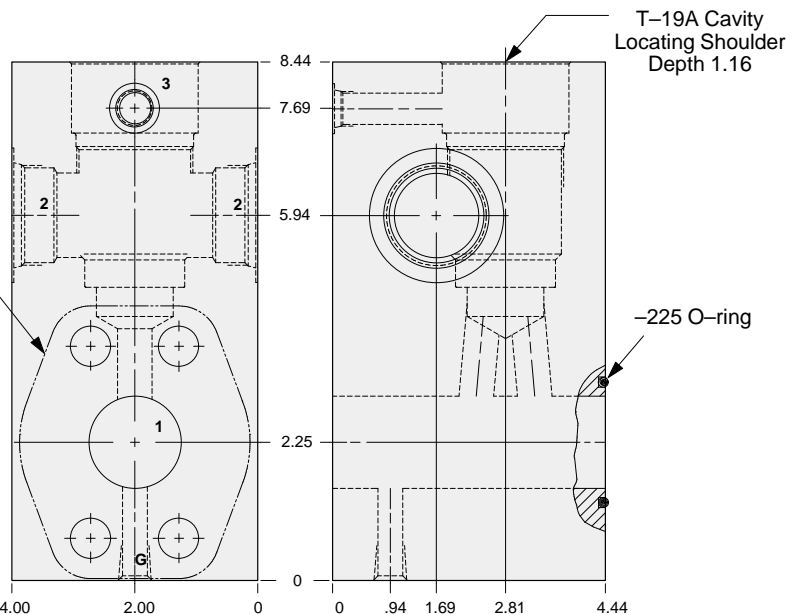

TYPICAL CARTRIDGES USED WITH THIS BODY

- RVIA - *** Page 1.19
- RSJC - *** Page 2.07
- SQJB - *** Page 2.09
- RSJE - *** Page 2.11
- SCIA - *** Page 2.13

Cartridge seal type determines O-ring type.

Instructions for ordering complete cartridge and body assemblies. Page v

Pressure ratings, material specifications. Page 11.02

SAE Specifications Page 11.03

Mounting Hole Dimensions	Port 2	Port 3	Gage Port	ALUMINUM		DUCTILE IRON	
				Part Number	List Price	Part Number	List Price
Inch	1.25 NPTF	.25 NPTF	.25 NPTF	WXT		WXT/S	
Inch	SAE-20	SAE-6	.25 NPTF	WXS		WXS/S	
Metric	1.25 BSPP	.25 BSPP	.25 BSPP	WXR/M		WXR/T	



LINE MOUNT BODIES



- Aluminum rated to 3000 psi.
- Ductile Iron rated to 5000 psi.

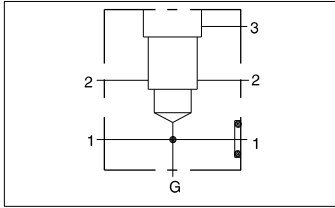

Sandwich mount through flange port 1.50" SAE Code 61 body with gage port.

1.50" SAE Code 61
4-Bolt Flange Pattern
4 places.
Port 1 through hole
Port 2 tapped hole

T-19A Cavity
Locating Shoulder
Depth 1.16

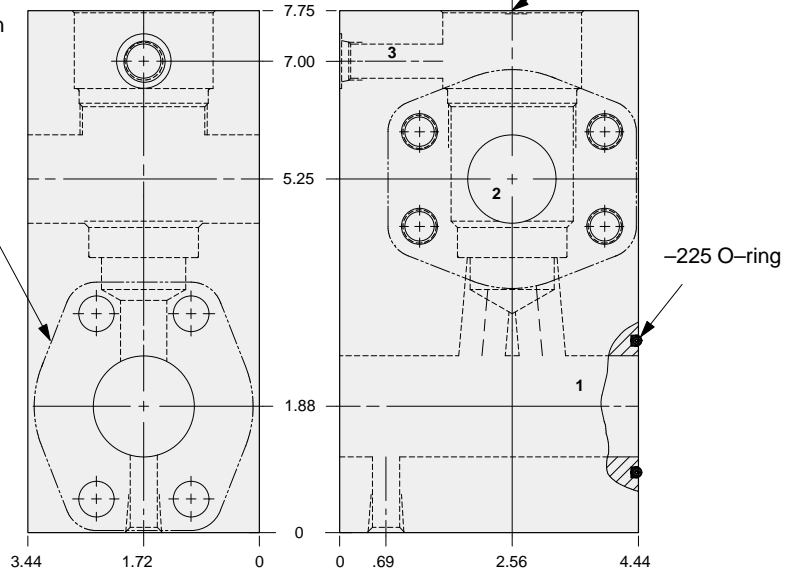

TYPICAL CARTRIDGES USED WITH THIS BODY

RVIA - ***	Page 1.19
RSJC - ***	Page 2.07
SQJB - ***	Page 2.09
RSJE - ***	Page 2.11
SCIA - ***	Page 2.13

Cartridge seal type determines O-ring type.

Instructions for ordering complete cartridge and body assemblies. Page v

Pressure ratings, material specifications. Page 11.02

SAE Specifications Page 11.03

Mounting Hole Dimensions	Port 3	Gage Port	ALUMINUM		DUCTILE IRON	
			Part Number	List Price	Part Number	List Price
Inch	SAE-6	.25 NPTF	ZMZ		ZMZ/S	
Metric	.25 BSPP	.25 BSPP	ZMZ/M		ZMZ/T	

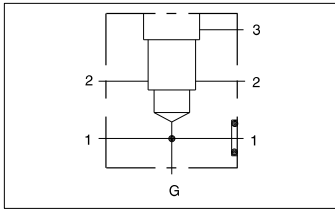

Sandwich mount through flange port 1.50" SAE Code 62 body with gage port.

1.50" SAE Code 62
4-Bolt Flange Pattern
4 places.
Port 1 through hole
Port 2 tapped hole

T-19A Cavity
Locating Shoulder
Depth 1.16

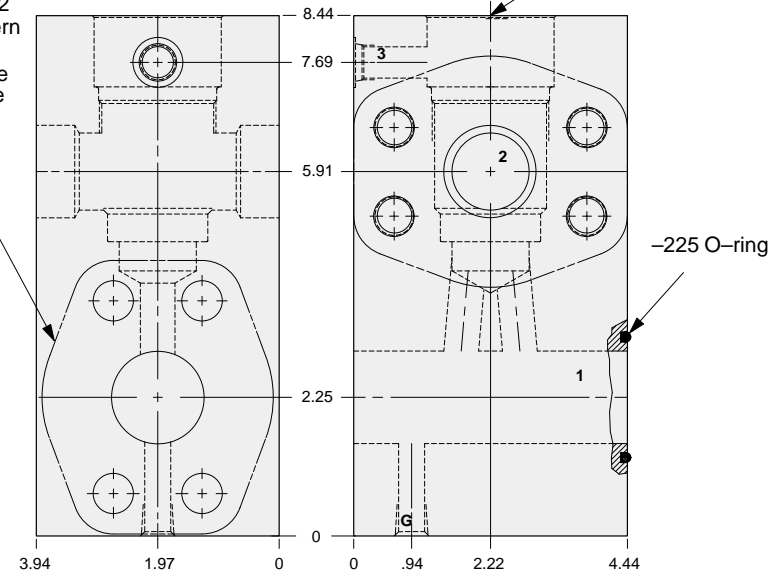

TYPICAL CARTRIDGES USED WITH THIS BODY

RVIA - ***	Page 1.19
RSJC - ***	Page 2.07
SQJB - ***	Page 2.09
RSJE - ***	Page 2.11
SCIA - ***	Page 2.13

Cartridge seal type determines O-ring type.

Instructions for ordering complete cartridge and body assemblies. Page v

Pressure ratings, material specifications. Page 11.02

SAE Specifications Page 11.03

Mounting Hole Dimensions	Port 3	Gage Port	ALUMINUM		DUCTILE IRON	
			Part Number	List Price	Part Number	List Price
Inch	SAE-6	.25 NPTF	WYA		WYA/S	
Metric	.25 BSPP	.25 BSPP	WYA/M		WYA/T	



LINE MOUNT BODIES



- Aluminum rated to 3000 psi.
- Ductile Iron rated to 5000 psi.

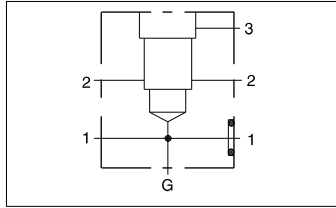

TYPICAL CARTRIDGES USED WITH THIS BODY

- | | |
|------------|-----------|
| RVIA - *** | Page 1.19 |
| RSJC - *** | Page 2.07 |
| SQJB - *** | Page 2.09 |
| RSJE - *** | Page 2.11 |
| SCIA - *** | Page 2.13 |

Cartridge seal type determines O-ring type.

Instructions for ordering complete cartridge and body assemblies. Page v

Pressure ratings, material specifications. Page 11.02

SAE Specifications Page 11.03

Flange mount through port 1.50" SAE Code 61 body with threaded outlet and gage port.

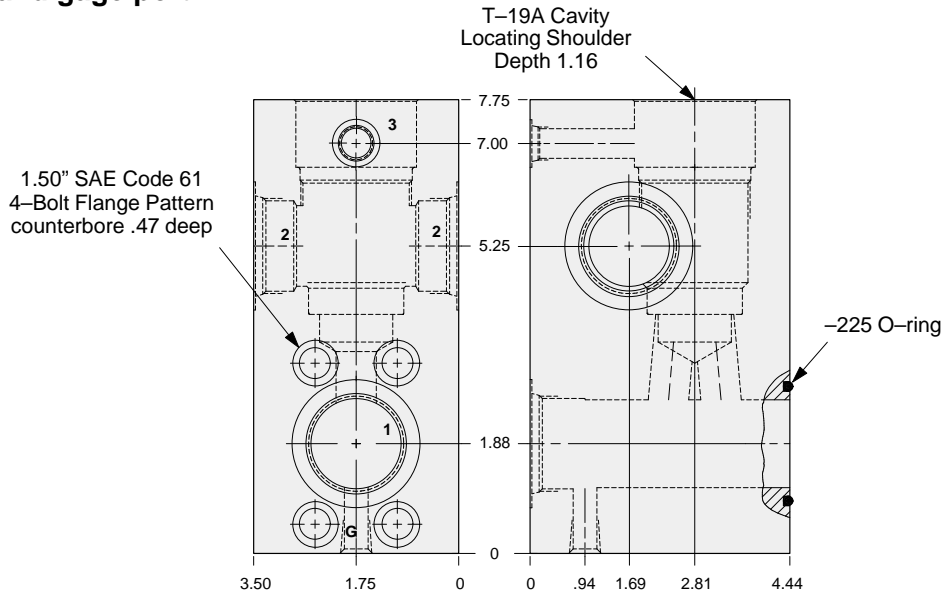

Mounting Hole Dimensions	Ports 1 & 2	Port 3	Gage Port	ALUMINUM		DUCTILE IRON	
				Part Number	List Price	Part Number	List Price
Inch	1.25 NPTF	.25 NPTF	.25 NPTF	WYQ		WYQ/S	
Inch	SAE-20	SAE-6	.25 NPTF	WYP		WYP/S	
Metric	1.25 BSPP	.25 BSPP	.25 BSPP	WYO/M		WYO/T	

S4
T19A

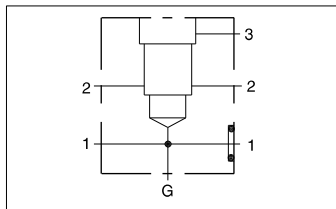

TYPICAL CARTRIDGES USED WITH THIS BODY

- | | |
|------------|-----------|
| RVIA - *** | Page 1.19 |
| RSJC - *** | Page 2.07 |
| SQJB - *** | Page 2.09 |
| RSJE - *** | Page 2.11 |
| SCIA - *** | Page 2.13 |

Cartridge seal type determines O-ring type.

Instructions for ordering complete cartridge and body assemblies. Page v

Pressure ratings, material specifications. Page 11.02

SAE Specifications Page 11.03

Flange mount through port 1.50" SAE Code 62 body with threaded outlet and gage port.

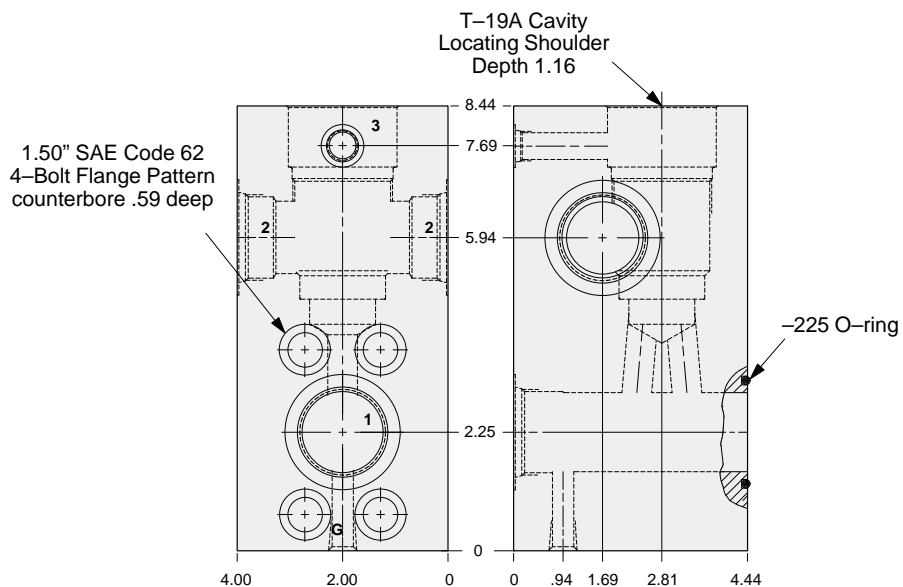

Mounting Hole Dimensions	Ports 1 & 2	Port 3	Gage Port	ALUMINUM		DUCTILE IRON	
				Part Number	List Price	Part Number	List Price
Inch	1.25 NPTF	.25 NPTF	.25 NPTF	WXQ		WXQ/S	
Inch	SAE-20	SAE-6	.25 NPTF	WXP		WXP/S	
Metric	1.25 BSPP	.25 BSPP	.25 BSPP	WXO/M		WXO/T	



LINE MOUNT BODIES



- Aluminum rated to 3000 psi.
- Ductile Iron rated to 5000 psi.

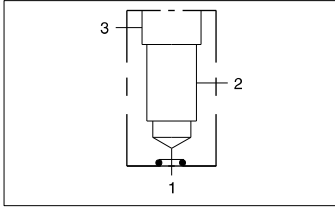

Direct mount 90 degree 2.00" SAE Code 61 flange port body.

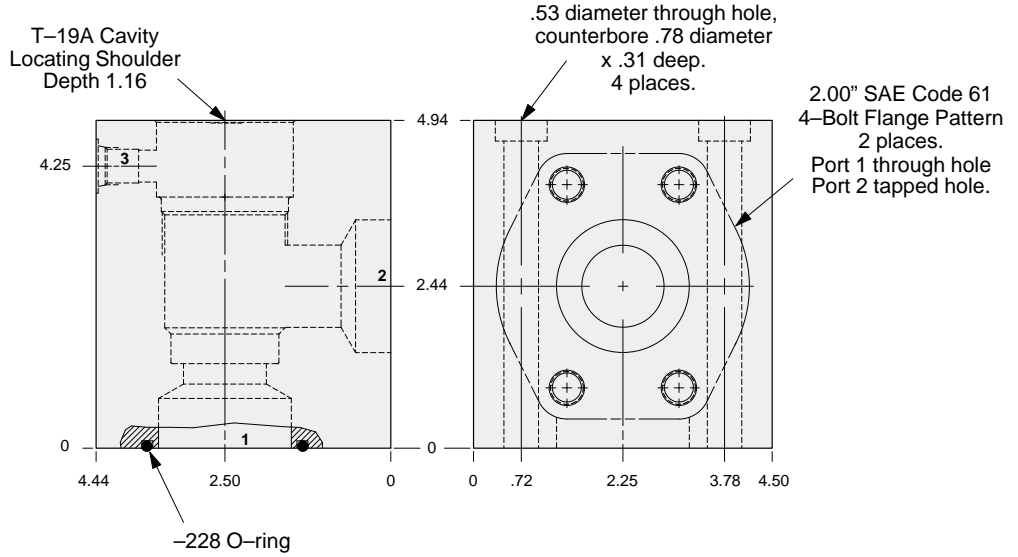

TYPICAL CARTRIDGES USED WITH THIS BODY

- CBIA - *** Page 4.11
- CBIG - *** Page 4.13
- CBIH - *** Page 4.15
- CKIB - *** Page 4.17

Cartridge seal type determines O-ring type.

Instructions for ordering complete cartridge and body assemblies. Page v

Pressure ratings, material specifications. Page 11.02

SAE Specifications Page 11.03

S4
T19A

Mounting Hole Dimensions	Port 3	ALUMINUM		DUCTILE IRON	
		Part Number	List Price	Part Number	List Price
Inch	SAE-6	ZGV		ZGV/S	
Metric	.25 BSPP	ZGV/M		ZGV/T	



LINE MOUNT BODIES



- Aluminum rated to 3000 psi.
- Ductile Iron rated to 5000 psi.

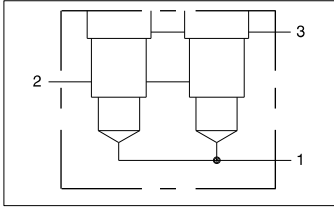

Two cavity 2.00" SAE Code 61 flange port high capacity body.

T-19A Cavity
Locating Shoulder
Depth 1.16
2 places.

2.00" SAE Code 61
4-Bolt Flange Pattern
2 places.

Mounting Holes:
Inch: .375-16 UNC-2B
x .62 deep.
Metric: M10 x 1.50-6H
x .62 deep.
2 places.

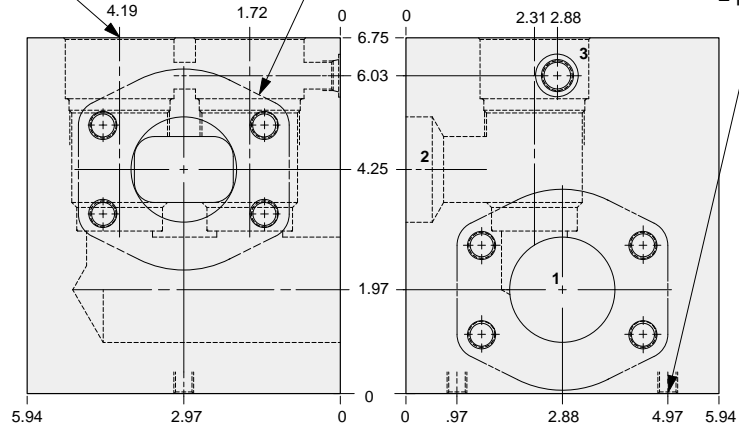

TYPICAL CARTRIDGES USED WITH THIS BODY

- CBIA - *** Page 4.11
- CBIG - *** Page 4.13
- CBIH - *** Page 4.15
- CKIB - *** Page 4.17

Instructions for ordering complete cartridge and body assemblies. Page v

Pressure ratings, material specifications. Page 11.02

SAE Specifications Page 11.03

Mounting Hole Dimensions	Port 3	ALUMINUM		DUCTILE IRON	
		Part Number	List Price	Part Number	List Price
Inch	SAE-6	XZZ		XZZ/S	
Metric	.25 BSPP	XZZ/M		XZZ/T	

S4
T19A

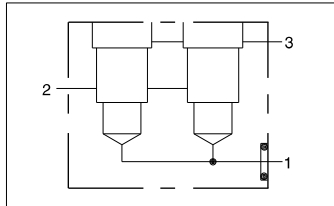

Two cavity direct mount 2.00" SAE Code 61 flange port high capacity body.

.53 diameter through hole
counterbore .78 diameter
x .44 deep.

T-19A Cavity
Locating Shoulder
Depth 1.16
2 places.

2.00" SAE Code 61
4-Bolt Flange Pattern
2 places.
Port 1 through hole
Port 2 tapped hole.

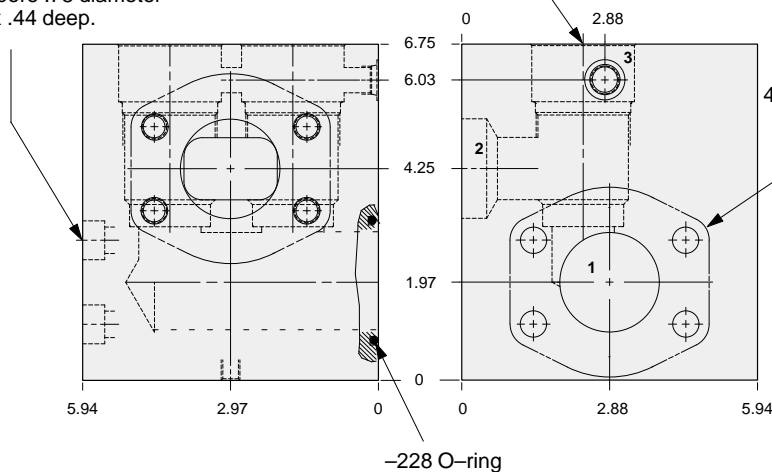

TYPICAL CARTRIDGES USED WITH THIS BODY

- CBIA - *** Page 4.11
- CBIG - *** Page 4.13
- CBIH - *** Page 4.15
- CKIB - *** Page 4.17

Cartridge seal type determines O-ring type.

Instructions for ordering complete cartridge and body assemblies. Page v

Pressure ratings, material specifications. Page 11.02

SAE Specifications Page 11.03

Mounting Hole Dimensions	Port 3	ALUMINUM		DUCTILE IRON	
		Part Number	List Price	Part Number	List Price
Inch	SAE-6	XVD		XVD/S	
Metric	.25 BSPP	XVD/M		XVD/T	



LINE MOUNT BODIES



- Aluminum rated to 3000 psi.
- Ductile Iron rated to 5000 psi.

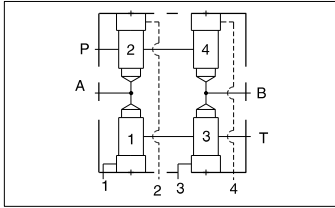

Four cavity four-way 1.50" SAE Code 61 flange port logic body for directional applications.

TYPICAL CARTRIDGES USED WITH THIS BODY

LOJC - ***	Page 9.09
LKJC - ***	Page 9.11
LPJC - ***	Page 9.13
LRJC - ***	Page 9.15

Instructions for ordering complete cartridge and body assemblies. Page v

Pressure ratings, material specifications. Page 11.02

SAE Specifications Page 11.03

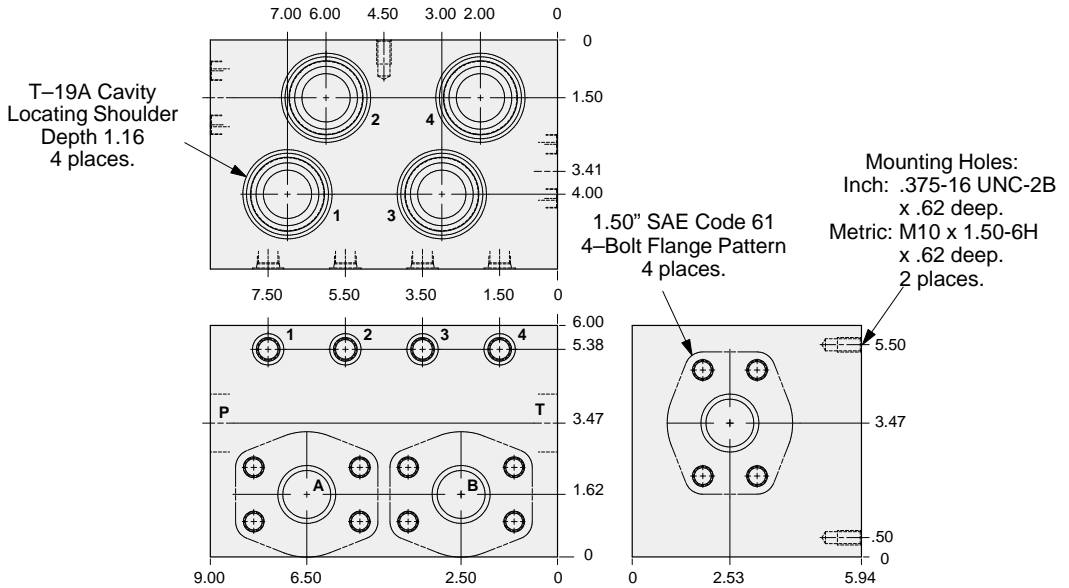

Mounting Hole Dimensions	Ports 1 & 2, 3 & 4	ALUMINUM		DUCTILE IRON	
		Part Number	List Price	Part Number	List Price
Inch	SAE-6	YRD		YRD/S	
Metric	.25 BSPP	YRD/M		YRD/T	

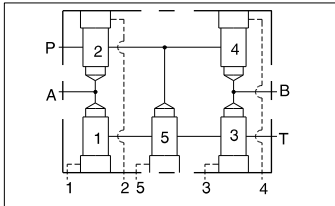

Five cavity four-way 1.50" SAE Code 61 flange port logic body for directional applications.

TYPICAL CARTRIDGES USED WITH THIS BODY

LOJC - ***	Page 9.09
LKJC - ***	Page 9.11
LPJC - ***	Page 9.13
LRJC - ***	Page 9.15

Instructions for ordering complete cartridge and body assemblies. Page v

Pressure ratings, material specifications. Page 11.02

SAE Specifications Page 11.03

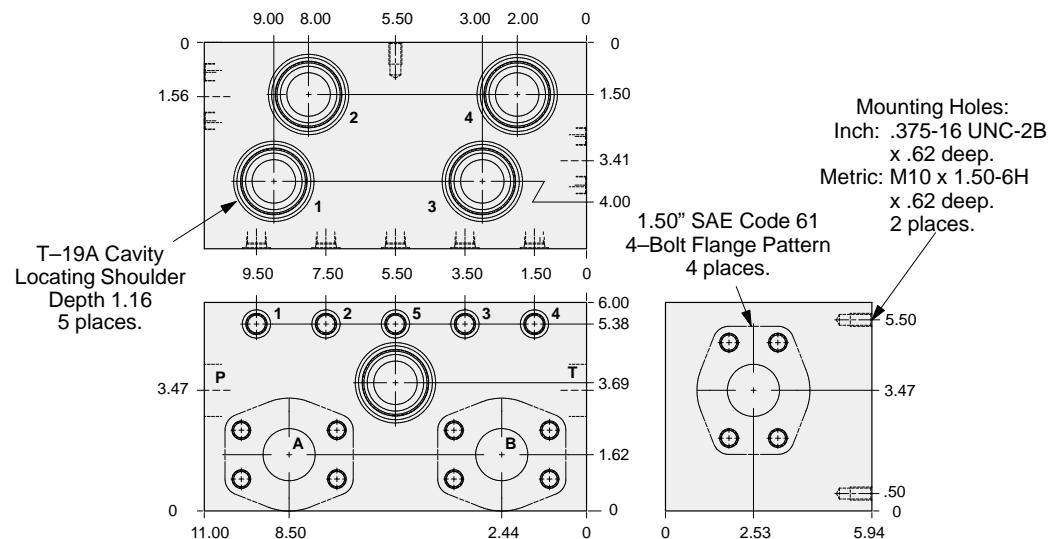

Mounting Hole Dimensions	Ports 1, 2, 3, 4, & 5	ALUMINUM		DUCTILE IRON	
		Part Number	List Price	Part Number	List Price
Inch	SAE-6	YQD		YQD/S	
Metric	.25 BSPP	YQD/M		YQD/T	



LINE MOUNT BODIES



- Aluminum rated to 3000 psi.
- Ductile Iron rated to 5000 psi.

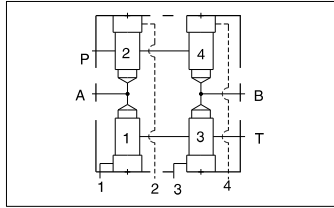

Four cavity four-way 2.00" SAE Code 61 flange port logic body for directional applications.

T-19A Cavity Locating Shoulder Depth 1.16
4 places.

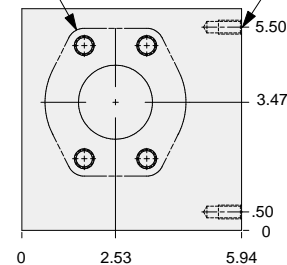
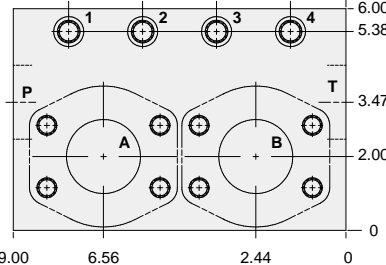
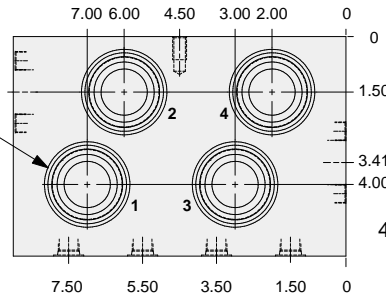

Mounting Holes:
Inch: .375-16 UNC-2B x .62 deep.
Metric: M10 x 1.50-6H x .62 deep.
2 places.

2.00" SAE Code 61 4-Bolt Flange Pattern
4 places.

TYPICAL CARTRIDGES USED WITH THIS BODY

- LOJC - *** Page 9.09
- LKJC - *** Page 9.11
- LPJC - *** Page 9.13
- LRJC - *** Page 9.15

Instructions for ordering complete cartridge and body assemblies. Page v

Pressure ratings, material specifications. Page 11.02

SAE Specifications Page 11.03

Mounting Hole Dimensions	Ports 1 & 2, 3 & 4	ALUMINUM		DUCTILE IRON	
		Part Number	List Price	Part Number	List Price
Inch	SAE-6	YRC		YRC/S	
Metric	.25 BSPP	YRC/M		YRC/T	

S4
T19A

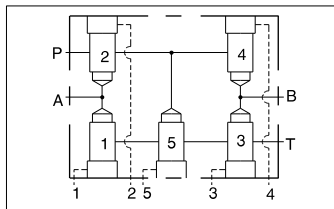

Five cavity four-way 2.00" SAE Code 61 flange port logic body for directional applications.

T-19A Cavity Locating Shoulder Depth 1.16
5 places.

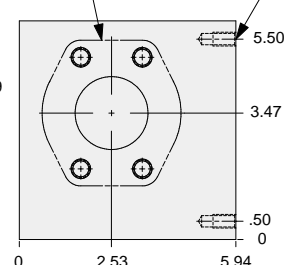
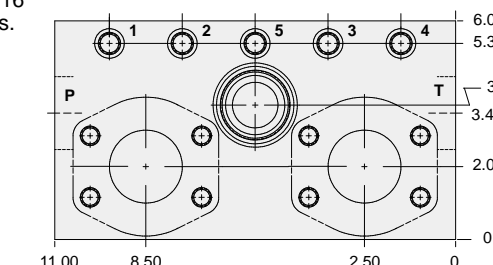
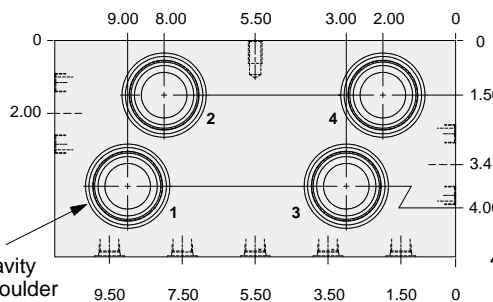

Mounting Holes:
Inch: .375-16 UNC-2B x .62 deep.
Metric: M10 x 1.50-6H x .62 deep.
2 places.

2.00" SAE Code 61 4-Bolt Flange Pattern
4 places.

TYPICAL CARTRIDGES USED WITH THIS BODY

- LOJC - *** Page 9.09
- LKJC - *** Page 9.11
- LPJC - *** Page 9.13
- LRJC - *** Page 9.15

Instructions for ordering complete cartridge and body assemblies. Page v

Pressure ratings, material specifications. Page 11.02

SAE Specifications Page 11.03

Mounting Hole Dimensions	Ports 1, 2, 3, 4, & 5	ALUMINUM		DUCTILE IRON	
		Part Number	List Price	Part Number	List Price
Inch	SAE-6	YQC		YQC/S	
Metric	.25 BSPP	YQC/M		YQC/T	



LINE MOUNT BODIES



- Aluminum rated to 3000 psi.
- Ductile Iron rated to 5000 psi.

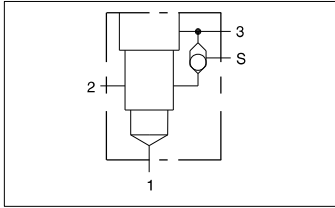

90 degree 1.50" SAE Code 61 flange port body with shuttle.

Mounting Holes:
 Inch: .375-16 UNC-2B
 x .62 deep.
 Metric: M10 x 1.50-6H
 x .62 deep.
 2 places.

1.50" SAE Code 61
 4-Bolt Flange Pattern
 2 places.

T-19A Cavity
 Locating Shoulder
 Depth 1.19
 2 places.

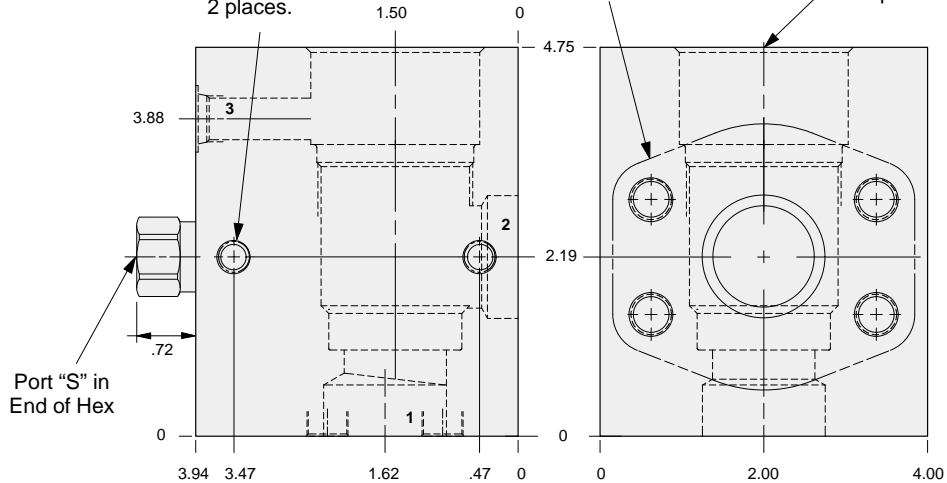

TYPICAL CARTRIDGES USED WITH THIS BODY

- CBIA - *** Page 4.11
 CBIG - *** Page 4.13
 CBIH - *** Page 4.15
 CKIB - *** Page 4.17

Cartridge seal type determines O-ring type.

Instructions for ordering complete cartridge and body assemblies. Page v

Pressure ratings, material specifications. Page 11.02

SAE Specifications Page 11.03

Mounting Hole Dimensions	Port 3	Shuttle Cartridge	Port S	ALUMINUM		DUCTILE IRON	
				Part Number	List Price	Part Number	List Price
Inch	SAE-6	CSAA - EXN	SAE-4	KGR		KGR/S	
Metric	.25 BSPP	CSAA - BXN	.25 BSPP	KGR/M		KGR/T	

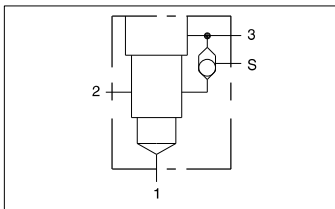

90 degree 1.50" SAE Code 62 flange port body with shuttle.

Mounting Holes:
 Inch: .375-16 UNC-2B
 x .62 deep.
 Metric: M10 x 1.50-6H
 x .62 deep.
 2 places.

1.50" SAE Code 62
 4-Bolt Flange Pattern
 2 places.

T-19A Cavity
 Locating Shoulder
 Depth 1.19

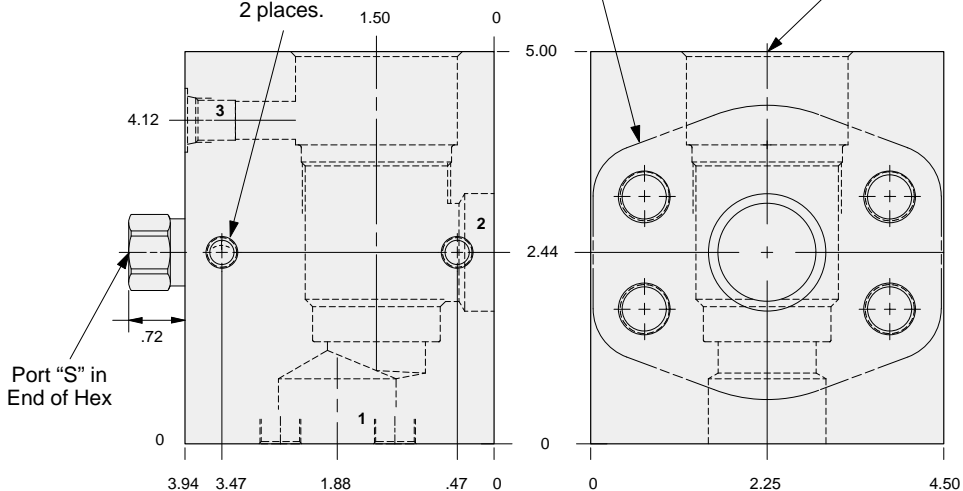

TYPICAL CARTRIDGES USED WITH THIS BODY

- CBIA - *** Page 4.11
 CBIG - *** Page 4.13
 CBIH - *** Page 4.15
 CKIB - *** Page 4.17

Cartridge seal type determines O-ring type.

Instructions for ordering complete cartridge and body assemblies. Page v

Pressure ratings, material specifications. Page 11.02

SAE Specifications Page 11.03

Mounting Hole Dimensions	Port 3	Shuttle Cartridge	Port S	ALUMINUM		DUCTILE IRON	
				Part Number	List Price	Part Number	List Price
Inch	SAE-6	CSAA - EXN	SAE-4	KG6		KG6/S	
Metric	.25 BSPP	CSAA - BXN	.25 BSPP	KG6/M		KG6/T	



LINE MOUNT BODIES

- Aluminum rated to 3000 psi.
- Ductile Iron rated to 5000 psi.

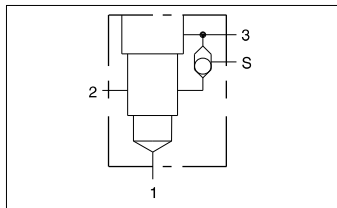

90 degree 2.00" SAE Code 61 flange port body with shuttle.

Mounting Holes:
 Inch: .375-16 UNC-2B
 x .62 deep.
 Metric: M10 x 1.50-6H
 x .62 deep.
 2 places.

T-19A Cavity
 Locating Shoulder
 Depth 1.19

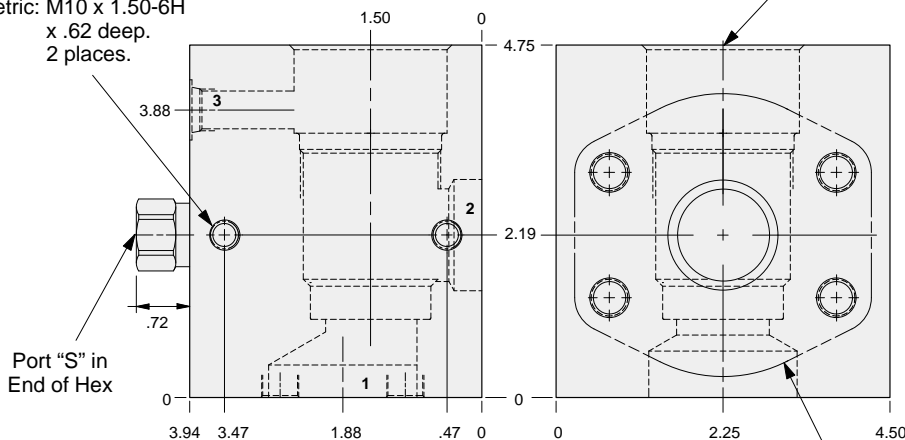

Port "S" in
 End of Hex

2.00" SAE Code 61
 4-Bolt Flange Pattern
 2 places.

TYPICAL CARTRIDGES USED WITH THIS BODY

- CBIA - *** Page 4.11
- CBIG - *** Page 4.13
- CBIH - *** Page 4.15
- CKIB - *** Page 4.17

Cartridge seal type determines O-ring type.

Instructions for ordering complete cartridge and body assemblies. Page v

Pressure ratings, material specifications. Page 11.02

SAE Specifications Page 11.03

Mounting Hole Dimensions	Port 3	Shuttle Cartridge	Port S	ALUMINUM		DUCTILE IRON	
				Part Number	List Price	Part Number	List Price
Inch	SAE-6	CSAA - EXN	SAE-4	KGS		KGS/S	
Metric	.25 BSPP	CSAA - BXN	.25 BSPP	KGS/M		KGS/T	

S4
T19A

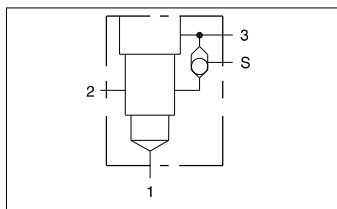

90 degree 2.00" SAE Code 62 flange port body with shuttle.

Mounting Holes:
 Inch: .375-16 UNC-2B
 x .62 deep.
 Metric: M10 x 1.50-6H
 x .62 deep.
 2 places.

2.00" SAE Code 62
 4-Bolt Flange Pattern
 2 places.

T-19A Cavity
 Locating Shoulder
 Depth 1.16

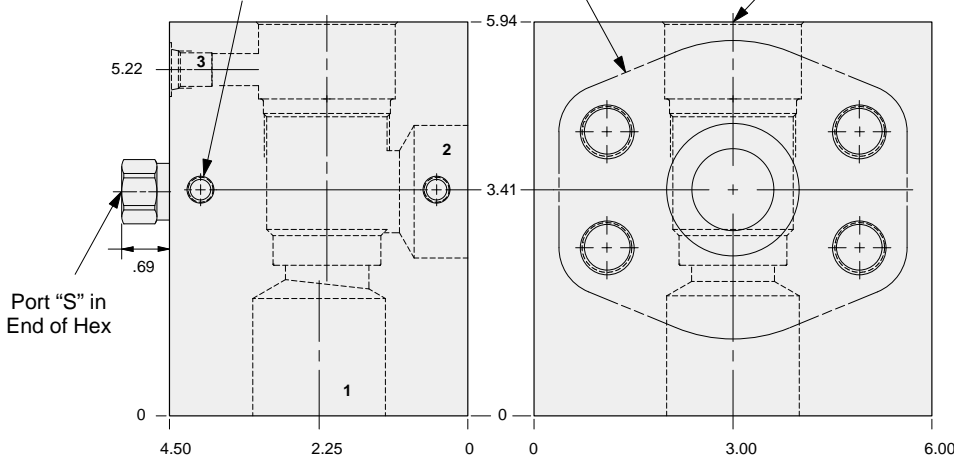

Port "S" in
 End of Hex

TYPICAL CARTRIDGES USED WITH THIS BODY

- CBIA - *** Page 4.11
- CBIG - *** Page 4.13
- CBIH - *** Page 4.15
- CKIB - *** Page 4.17

Cartridge seal type determines O-ring type.

Instructions for ordering complete cartridge and body assemblies. Page v

Pressure ratings, material specifications. Page 11.02

SAE Specifications Page 11.03

Mounting Hole Dimensions	Port 3	Shuttle Cartridge	Port S	ALUMINUM		DUCTILE IRON	
				Part Number	List Price	Part Number	List Price
Inch	SAE-6	CSAA - EXN	SAE-4	KG8		KG8/S	
Metric	.25 BSPP	CSAA - BXN	.25 BSPP	KG8/M		KG8/T	



LINE MOUNT BODIES



- Aluminum rated to 3000 psi.
- Ductile Iron rated to 5000 psi.

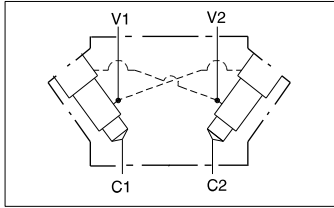

Two cavity cross-piloted inline 1.50" SAE Code 61 flange port body for load control applications.

TYPICAL CARTRIDGES USED WITH THIS BODY

- CBIA - *** Page 4.11
- CBIG - *** Page 4.13
- CBIH - *** Page 4.15
- CKIB - *** Page 4.17

Instructions for ordering complete cartridge and body assemblies. Page v

Pressure ratings, material specifications. Page 11.02

SAE Specifications Page 11.03

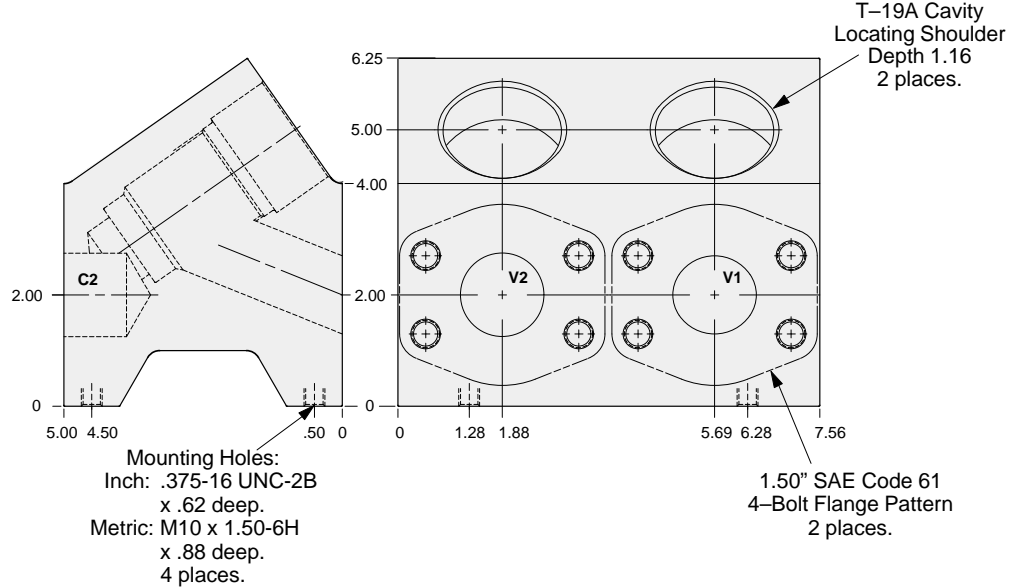

Mounting Hole Dimensions	ALUMINUM		DUCTILE IRON	
	Part Number	List Price	Part Number	List Price
Inch	XZP		XZP/S	
Metric	XZP/M		XZP/T	

S4
T19A

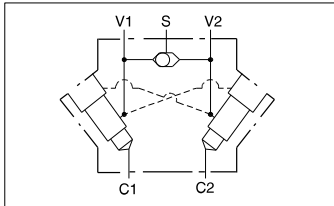

Two cavity cross-piloted inline 1.50" SAE Code 61 flange port body with shuttle for load control applications.

TYPICAL CARTRIDGES USED WITH THIS BODY

- CBIA - *** Page 4.11
- CBIG - *** Page 4.13
- CBIH - *** Page 4.15
- CKIB - *** Page 4.17

Cartridge seal type determines O-ring type.

Instructions for ordering complete cartridge and body assemblies. Page v

Pressure ratings, material specifications. Page 11.02

SAE Specifications Page 11.03

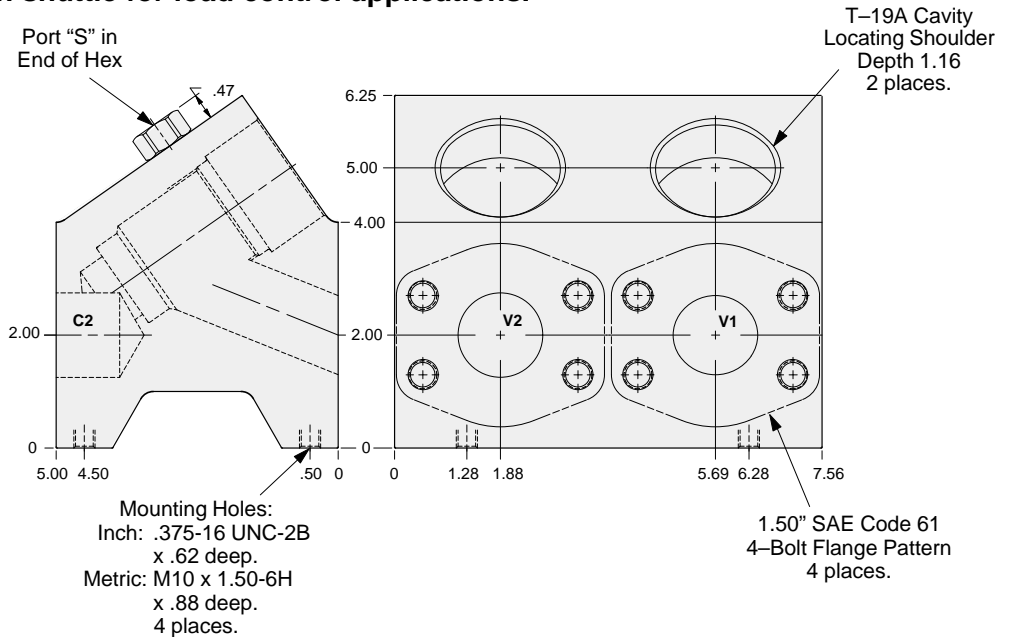

Mounting Hole Dimensions	Shuttle Cartridge	Port S	ALUMINUM		DUCTILE IRON	
			Part Number	List Price	Part Number	List Price
Inch	CSAA - EXN	SAE-4	XZQ		XZQ/S	
Metric	CSAA - BXN	.25 BSPP	XZQ/M		XZQ/T	



LINE MOUNT BODIES



- Aluminum rated to 3000 psi.
- Ductile Iron rated to 5000 psi.

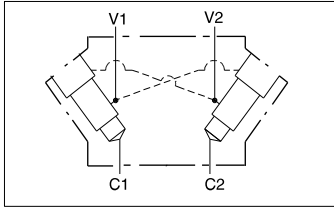

Two cavity cross-piloted inline 2.00" SAE Code 61 flange port body for load control applications.

Mounting Holes:
 Inch: .375-16 UNC-2B
 x .62 deep.
 Metric: M10 x 1.50-6H
 x .88 deep.
 4 places.

T-19A Cavity Locating Shoulder
 Depth 1.16
 2 places.
 2.00" SAE Code 61
 4-Bolt Flange Pattern
 4 places.

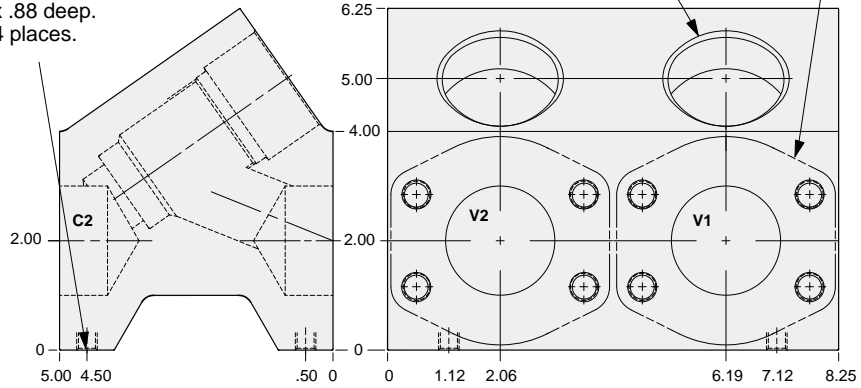

TYPICAL CARTRIDGES USED WITH THIS BODY

- CBIA - *** Page 4.11
 CBIG - *** Page 4.13
 CBIH - *** Page 4.15
 CKIB - *** Page 4.17

Instructions for ordering complete cartridge and body assemblies. Page v

Pressure ratings, material specifications. Page 11.02

SAE Specifications Page 11.03

Mounting Hole Dimensions	ALUMINUM		DUCTILE IRON	
	Part Number	List Price	Part Number	List Price
Inch	XZR		XZR/S	
Metric	XZR/M		XZR/T	

S4
T19A

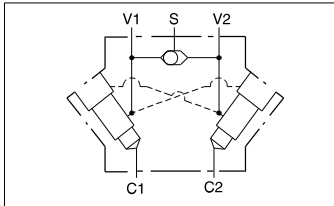

Two cavity cross-piloted inline 2.00" SAE Code 61 flange port body with shuttle for load control applications.

Mounting Holes:
 Inch: .375-16 UNC-2B
 x .62 deep.
 Metric: M10 x 1.50-6H
 x .88 deep.
 4 places.

Port "S" in End of Hex

T-19A Cavity Locating Shoulder
 Depth 1.16
 2 places.
 2.00" SAE Code 61
 4-Bolt Flange Pattern
 4 places.

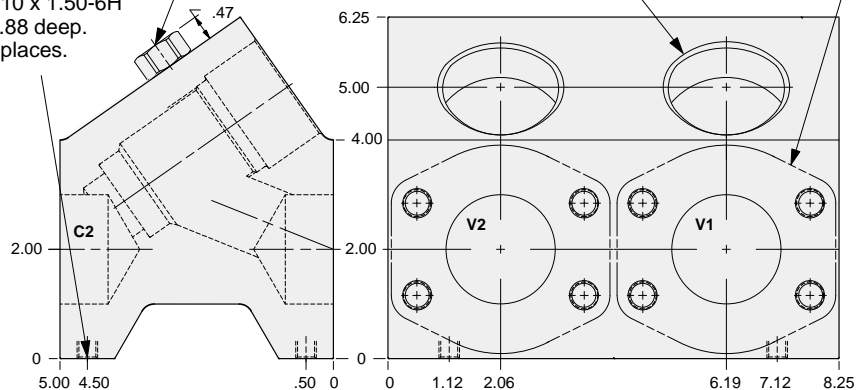

TYPICAL CARTRIDGES USED WITH THIS BODY

- CBIA - *** Page 4.11
 CBIG - *** Page 4.13
 CBIH - *** Page 4.15
 CKIB - *** Page 4.17

Cartridge seal type determines O-ring type.

Instructions for ordering complete cartridge and body assemblies. Page v

Pressure ratings, material specifications. Page 11.02

SAE Specifications Page 11.03

Mounting Hole Dimensions	Shuttle Cartridge	Port S	ALUMINUM		DUCTILE IRON	
			Part Number	List Price	Part Number	List Price
Inch	CSAA - EXN	SAE-4	XZS		XZS/S	
Metric	CSAA - BXN	.25 BSPP	XZS/M		XZS/T	



LINE MOUNT BODIES



- Aluminum rated to 3000 psi.
- Ductile Iron rated to 5000 psi.

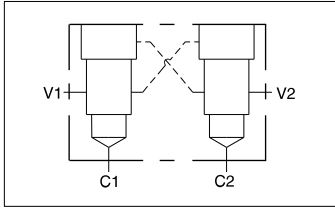

Two cavity 90 degree cross-piloted 1.50" SAE Code 61 flange port body for load control applications.

1.50" SAE Code 61
4-Bolt Flange Pattern
4 places.

T-19A Cavity
Locating Shoulder
Depth 1.19
2 places.

Mounting Holes:
(opposite side)
Inch: .375-16 UNC-2B
x .62 deep.
Metric: M10 x 1.50-6H
x .62 deep.
2 places.

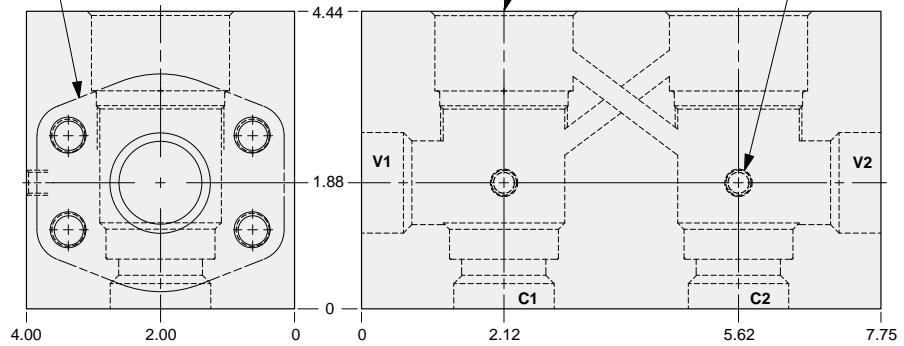

TYPICAL CARTRIDGES USED WITH THIS BODY

CBIA - ***	Page 4.11
CBIG - ***	Page 4.13
CBIH - ***	Page 4.15
CKIB - ***	Page 4.17

Instructions for ordering
complete cartridge and body
assemblies. Page v

Pressure ratings, material
specifications. Page 11.02

SAE Specifications Page 11.03

Mounting Hole Dimensions	ALUMINUM		DUCTILE IRON	
	Part Number	List Price	Part Number	List Price
Inch	YMR		YMR/S	
Metric	YMR/M		YMR/T	

S4
T19A

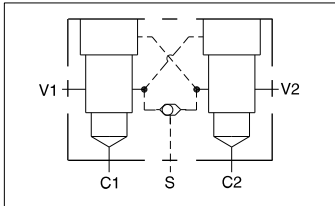

Two cavity 90 degree cross-piloted 1.50" SAE Code 61 flange port body with shuttle for load control applications.

1.50" SAE Code 61
4-Bolt Flange Pattern
4 places.

T-19A Cavity
Locating Shoulder
Depth 1.19
2 places.

Mounting Holes:
(opposite side)
Inch: .375-16 UNC-2B
x .62 deep.
Metric: M10 x 1.50-6H
x .62 deep.
2 places.

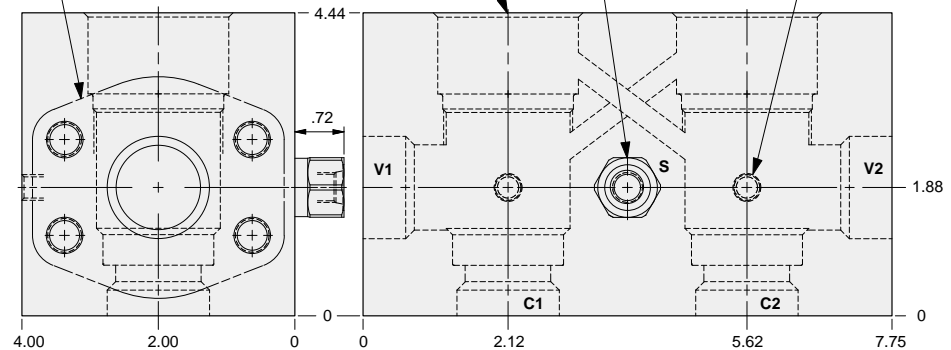

TYPICAL CARTRIDGES USED WITH THIS BODY

CBIA - ***	Page 4.11
CBIG - ***	Page 4.13
CBIH - ***	Page 4.15
CKIB - ***	Page 4.17

Cartridge seal type determines
O-ring type.

Instructions for ordering
complete cartridge and body
assemblies. Page v

Pressure ratings, material
specifications. Page 11.02

SAE Specifications Page 11.03

Mounting Hole Dimensions	Shuttle Cartridge	Port S	ALUMINUM		DUCTILE IRON	
			Part Number	List Price	Part Number	List Price
Inch	CSAA - EXN	SAE-4	YNR		YNR/S	
Metric	CSAA - BXN	.25 BSPF	YNR/M		YNR/T	



LINE MOUNT BODIES



- Aluminum rated to 3000 psi.
- Ductile Iron rated to 5000 psi.

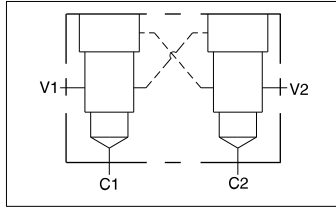

Two cavity 90 degree cross-piloted 1.50" SAE Code 62 flange port body for load control applications.

TYPICAL CARTRIDGES USED WITH THIS BODY

CBIA - ***	Page 4.11
CBIG - ***	Page 4.13
CBIH - ***	Page 4.15
CKIB - ***	Page 4.17

Instructions for ordering complete cartridge and body assemblies. Page v

Pressure ratings, material specifications. Page 11.02

SAE Specifications Page 11.03

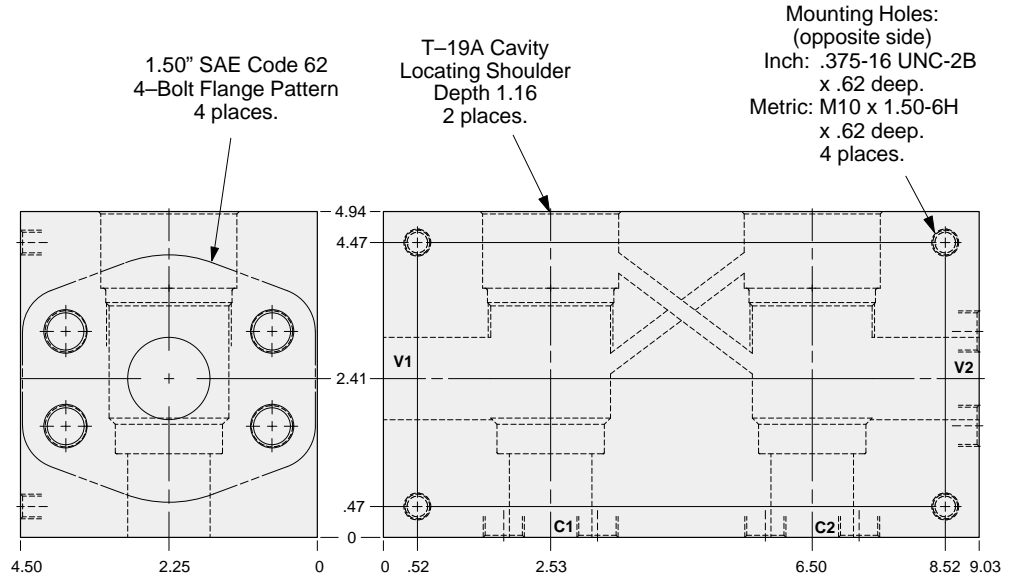

Mounting Hole Dimensions	ALUMINUM		DUCTILE IRON	
	Part Number	List Price	Part Number	List Price
Inch	YM6		YM6/S	
Metric	YM6/M		YM6/T	

S4
T19A

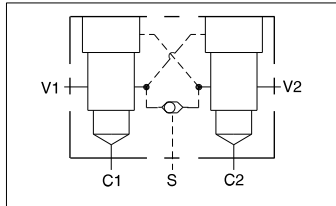

Two cavity 90 degree cross-piloted 1.50" SAE Code 62 flange port body with shuttle for load control applications.

TYPICAL CARTRIDGES USED WITH THIS BODY

CBIA - ***	Page 4.11
CBIG - ***	Page 4.13
CBIH - ***	Page 4.15
CKIB - ***	Page 4.17

Cartridge seal type determines O-ring type.

Instructions for ordering complete cartridge and body assemblies. Page v

Pressure ratings, material specifications. Page 11.02

SAE Specifications Page 11.03

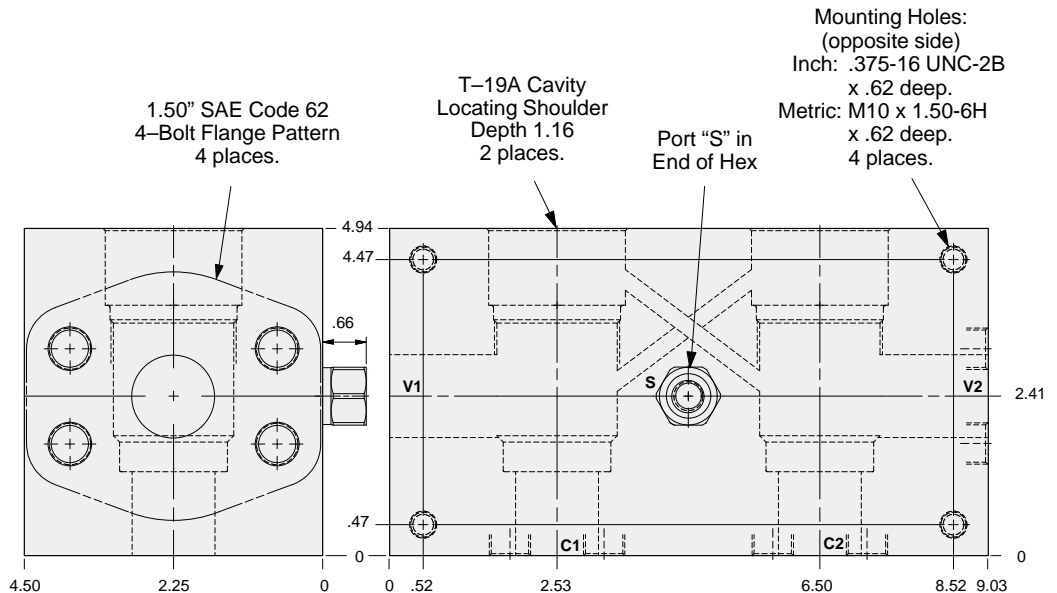

Mounting Hole Dimensions	Shuttle Cartridge	Port S	ALUMINUM		DUCTILE IRON	
			Part Number	List Price	Part Number	List Price
Inch	CSAA - EXN	SAE-4	YN6		YN6/S	
Metric	CSAA - BXN	.25 BSPP	YN6/M		YN6/T	



LINE MOUNT BODIES



- Aluminum rated to 3000 psi.
- Ductile Iron rated to 5000 psi.

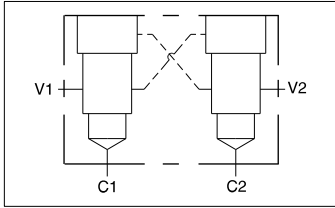

Two cavity 90 degree cross-piloted 2.00" SAE Code 61 flange port body for load control applications.

TYPICAL CARTRIDGES USED WITH THIS BODY

CBIA - ***	Page 4.11
CBIG - ***	Page 4.13
CBIH - ***	Page 4.15
CKIB - ***	Page 4.17

Instructions for ordering complete cartridge and body assemblies. Page v

Pressure ratings, material specifications. Page 11.02

SAE Specifications Page 11.03

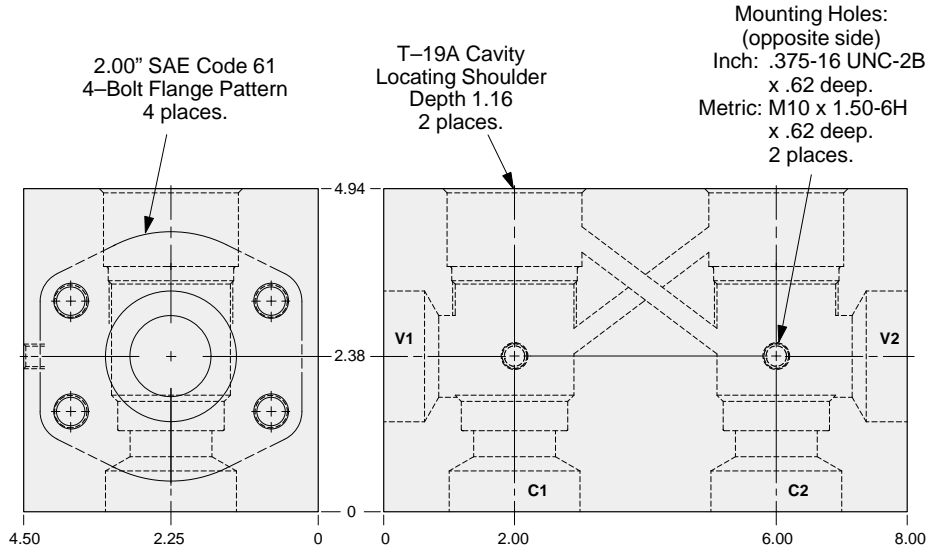

Mounting Hole Dimensions	ALUMINUM		DUCTILE IRON	
	Part Number	List Price	Part Number	List Price
Inch	YMS		YMS/S	
Metric	YMS/M		YMS/T	

S4
T19A

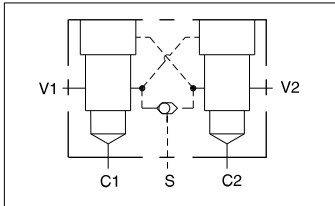

Two cavity 90 degree cross-piloted 2.00" SAE Code 61 flange port body with shuttle for load control applications.

TYPICAL CARTRIDGES USED WITH THIS BODY

CBIA - ***	Page 4.11
CBIG - ***	Page 4.13
CBIH - ***	Page 4.15
CKIB - ***	Page 4.17

Cartridge seal type determines O-ring type.

Instructions for ordering complete cartridge and body assemblies. Page v

Pressure ratings, material specifications. Page 11.02

SAE Specifications Page 11.03

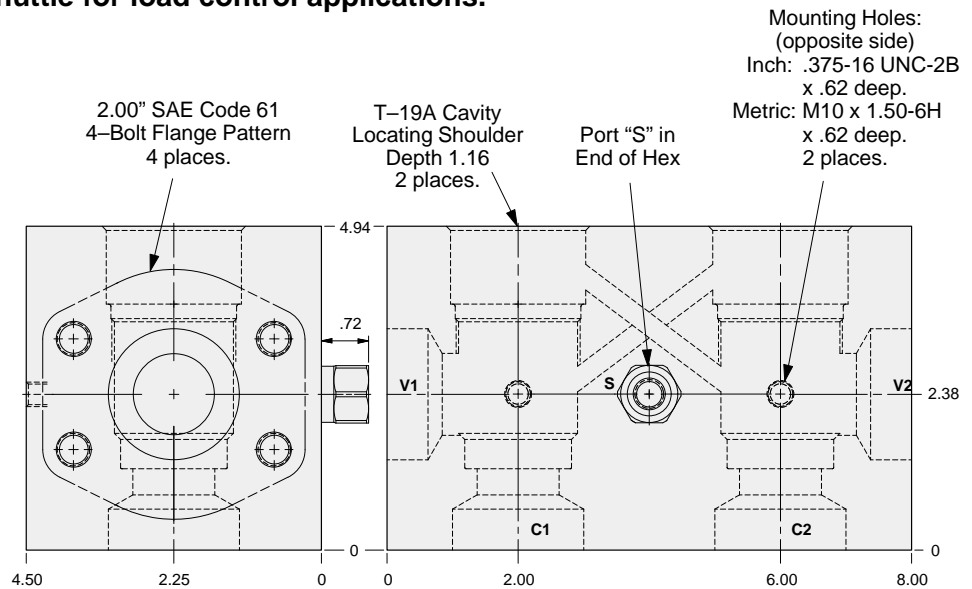

Mounting Hole Dimensions	Shuttle Cartridge	Port S	ALUMINUM		DUCTILE IRON	
			Part Number	List Price	Part Number	List Price
Inch	CSAA - EXN	SAE-4	YNS		YNS/S	
Metric	CSAA - BXN	.25 B5PP	YNS/M		YNS/T	



LINE MOUNT BODIES



- Aluminum rated to 3000 psi.
- Ductile Iron rated to 5000 psi.

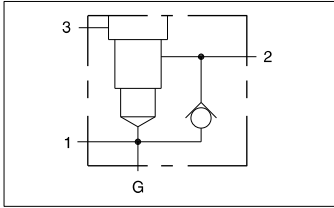

Body with reverse free flow check and gage port.

Mounting Holes:
.42 diameter through hole.
2 places.

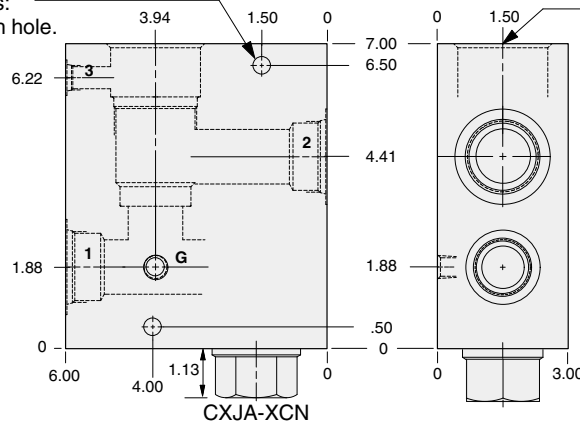

TYPICAL CARTRIDGES USED WITH THIS BODY

- | | |
|------------|-----------|
| RVIA - *** | Page 1.19 |
| RSJC - *** | Page 2.07 |
| SQJB - *** | Page 2.09 |
| RSJE - *** | Page 2.11 |

Cartridge seal type determines check valve seal type.

Instructions for ordering complete cartridge and body assemblies. Page v

Pressure ratings, material specifications. Page 11.02

Ports 1 & 2	Port 3	Gage Port	ALUMINUM		DUCTILE IRON	
			Part Number	List Price	Part Number	List Price
.75 NPTF	.25 NPTF	.25 NPTF	K6D		K6D/S	
1.00 NPTF	.25 NPTF	.25 NPTF	K6E		K6E/S	
1.25 NPTF	.25 NPTF	.25 NPTF	K6F		K6F/S	
SAE-12	SAE-6	.25 NPTF	K6L		K6L/S	
SAE-16	SAE-6	.25 NPTF	K6M		K6M/S	
SAE-20	SAE-6	.25 NPTF	K6N		K6N/S	
.75 BSPP	.25 BSPP	.25 BSPP	K6W		K6W/S	
1.00 BSPP	.25 BSPP	.25 BSPP	K6X		K6X/S	
1.25 BSPP	.25 BSPP	.25 BSPP	K6Y		K6Y/S	

S4
T19A



LINE MOUNT BODIES



- Aluminum rated to 3000 psi.
- Ductile Iron rated to 5000 psi.

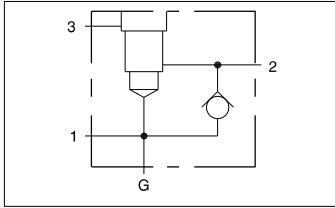

1.25" SAE Code 61 flange port body with reverse free flow check and gage port.

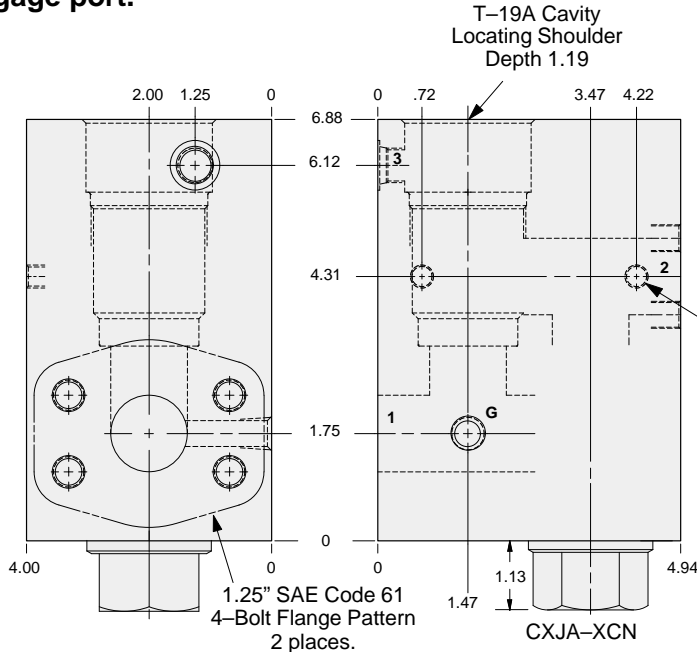

Mounting Holes:
(opposite side)
Inch: .375-16 UNC-2B
x .38 deep.
Metric: M10 x 1.50-6H
x .38 deep.
2 places.

TYPICAL CARTRIDGES USED WITH THIS BODY

RVIA - ***	Page 1.19
RSJC - ***	Page 2.07
SQJB - ***	Page 2.09
RSJE - ***	Page 2.11

Cartridge seal type determines check valve seal type.

Instructions for ordering complete cartridge and body assemblies. Page v

Pressure ratings, material specifications. Page 11.02

SAE Specifications Page 11.03

Mounting Hole Dimensions	Port 3	Gage Port	ALUMINUM		DUCTILE IRON	
			Part Number	List Price	Part Number	List Price
Inch	SAE-6	.25 NPTF	K6Q		K6Q/S	
Metric	.25 BSPP	.25 BSPP	K6Q/M		K6Q/T	

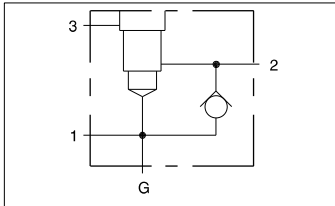

1.25" SAE Code 62 flange port body with reverse free flow check and gage port.

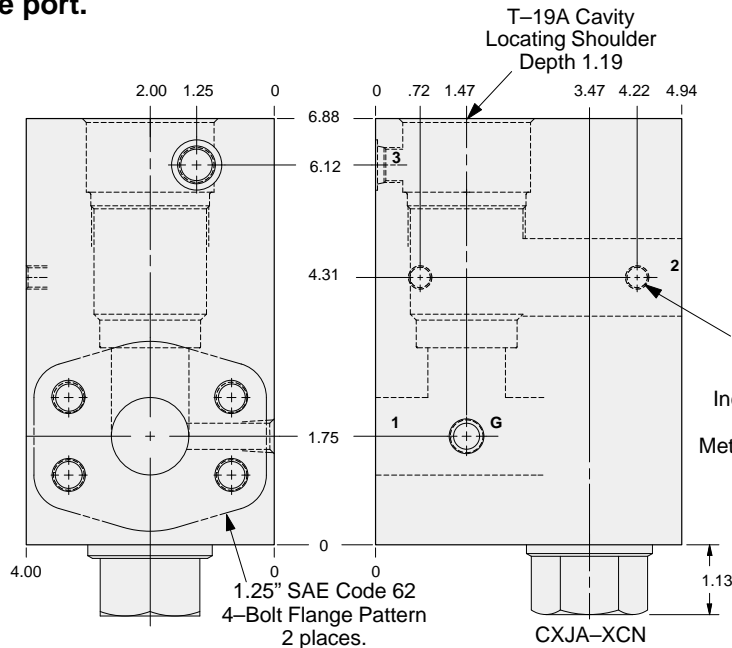

Mounting Holes:
(opposite side)
Inch: .375-16 UNC-2B
x .62 deep.
Metric: M10 x 1.50-6H
x .62 deep.
2 places.

TYPICAL CARTRIDGES USED WITH THIS BODY

RVIA - ***	Page 1.19
RSJC - ***	Page 2.07
SQJB - ***	Page 2.09
RSJE - ***	Page 2.11

Cartridge seal type determines check valve seal type.

Instructions for ordering complete cartridge and body assemblies. Page v

Pressure ratings, material specifications. Page 11.02

SAE Specifications Page 11.03

Mounting Hole Dimensions	Port 3	Gage Port	ALUMINUM		DUCTILE IRON	
			Part Number	List Price	Part Number	List Price
Inch	SAE-6	.25 NPTF	K65		K65/S	
Metric	.25 BSPP	.25 BSPP	K65/M		K65/T	



LINE MOUNT BODIES



- Aluminum rated to 3000 psi.
- Ductile Iron rated to 5000 psi.

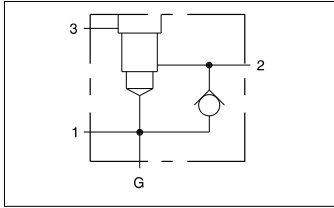

1.50" SAE Code 61 flange port body with reverse free flow check and gage port.

1.50" SAE Code 61
4-Bolt Flange Pattern
2 places.

T-19A Cavity
Locating Shoulder
Depth 1.19

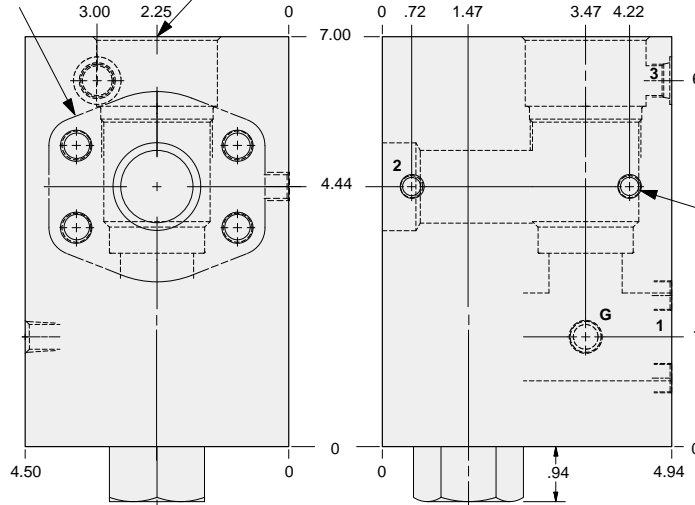

Mounting Holes:
Inch: .375-16 UNC-2B
x .62 deep.
Metric: M10 x 1.50-6H
x .62 deep.
2 places.

CXJA-XCN

TYPICAL CARTRIDGES USED WITH THIS BODY

RVIA - ***	Page 1.19
RSJC - ***	Page 2.07
SQJB - ***	Page 2.09
RSJE - ***	Page 2.11

Cartridge seal type determines check valve seal type.

Instructions for ordering complete cartridge and body assemblies. Page v

Pressure ratings, material specifications. Page 11.02

SAE Specifications Page 11.03

Mounting Hole Dimensions	Port 3	Gage Port	ALUMINUM		DUCTILE IRON	
			Part Number	List Price	Part Number	List Price
Inch	SAE-6	.25 NPTF	K6R		K6R/S	
Metric	.25 BSPP	.25 BSPP	K6R/M		K6R/T	

S4
T19A

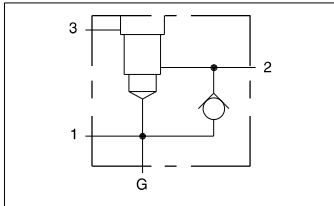

1.50" SAE Code 62 flange port body with reverse free flow check and gage port.

1.50" SAE Code 62
4-Bolt Flange Pattern
2 places.

T-19A Cavity
Locating Shoulder
Depth 1.19

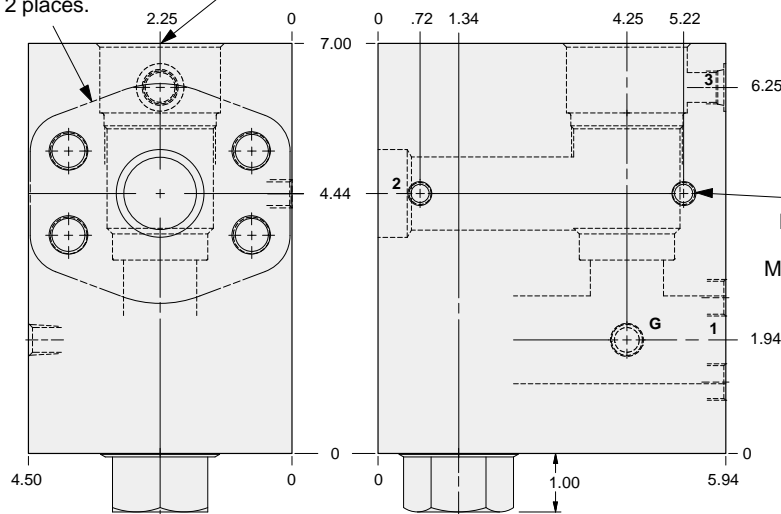

Mounting Holes:
Inch: .375-16 UNC-2B
x .62 deep.
Metric: M10 x 1.50-6H
x .62 deep.
2 places.

CXJA-XCN

TYPICAL CARTRIDGES USED WITH THIS BODY

RVIA - ***	Page 1.19
RSJC - ***	Page 2.07
SQJB - ***	Page 2.09
RSJE - ***	Page 2.11

Cartridge seal type determines check valve seal type.

Instructions for ordering complete cartridge and body assemblies. Page v

Pressure ratings, material specifications. Page 11.02

SAE Specifications Page 11.03

Mounting Hole Dimensions	Port 3	Gage Port	ALUMINUM		DUCTILE IRON	
			Part Number	List Price	Part Number	List Price
Inch	SAE-6	.25 NPTF	K66		K66/S	
Metric	.25 BSPP	.25 BSPP	K66/M		K66/T	



LINE MOUNT BODIES



- Aluminum rated to 3000 psi.
- Ductile Iron rated to 5000 psi.

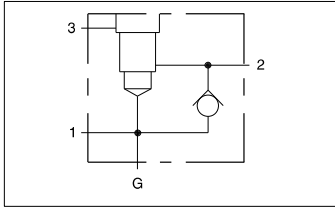

2.00" SAE Code 61 flange port body with reverse free flow check and gage port.

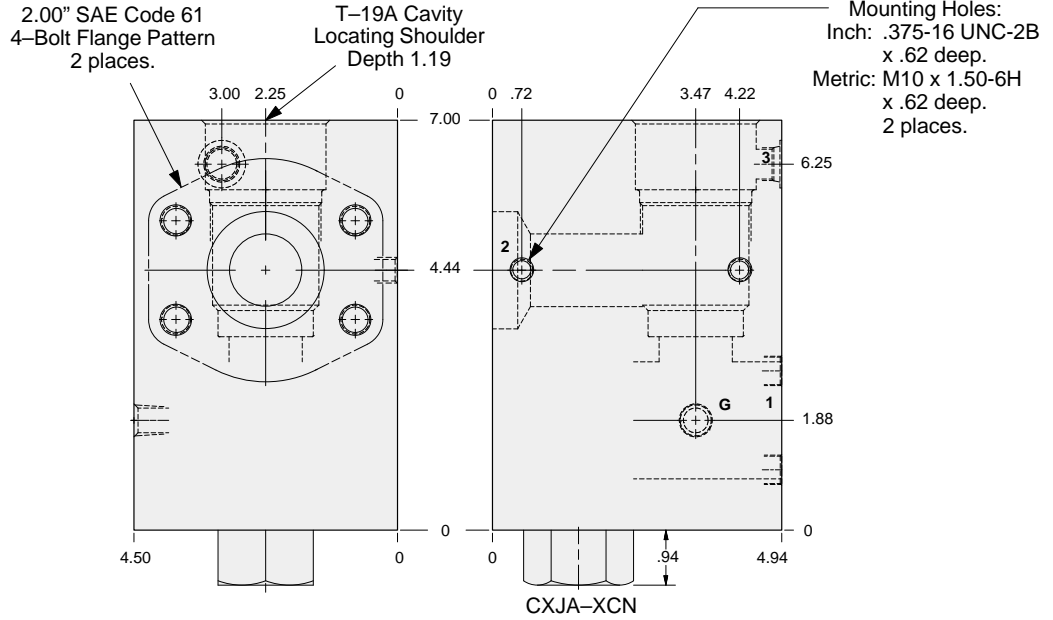

TYPICAL CARTRIDGES USED WITH THIS BODY

RVIA - ***	Page 1.19
RSJC - ***	Page 2.07
SQJB - ***	Page 2.09
RSJE - ***	Page 2.11

Cartridge seal type determines check valve seal type.

Instructions for ordering complete cartridge and body assemblies. Page v

Pressure ratings, material specifications. Page 11.02

SAE Specifications Page 11.03

Mounting Hole Dimensions	Port 3	Gage Port	ALUMINUM		DUCTILE IRON	
			Part Number	List Price	Part Number	List Price
Inch	SAE-6	.25 NPTF	K6S		K6S/S	
Metric	.25 BSPP	.25 BSPP	K6S/M		K6S/T	

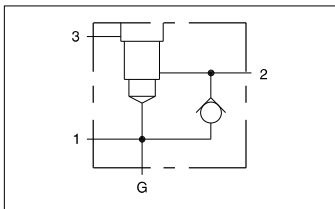

2.00" SAE Code 62 flange port body with reverse free flow check and gage port.

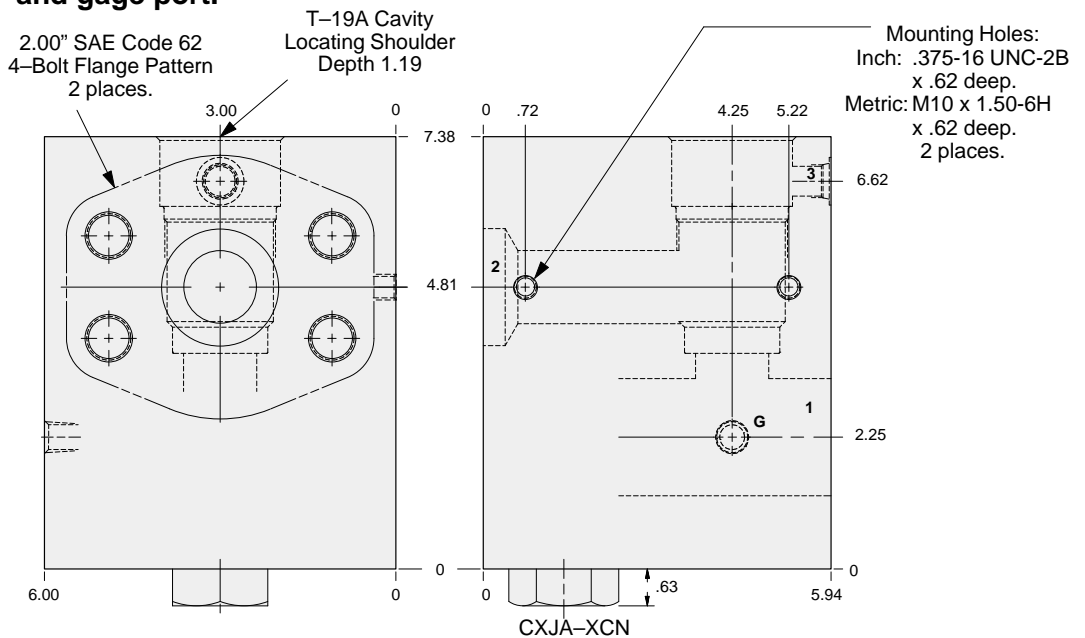

TYPICAL CARTRIDGES USED WITH THIS BODY

RVIA - ***	Page 1.19
RSJC - ***	Page 2.07
SQJB - ***	Page 2.09
RSJE - ***	Page 2.11

Cartridge seal type determines check valve seal type.

Instructions for ordering complete cartridge and body assemblies. Page v

Pressure ratings, material specifications. Page 11.02

SAE Specifications Page 11.03

Mounting Hole Dimensions	Port 3	Gage Port	ALUMINUM		DUCTILE IRON	
			Part Number	List Price	Part Number	List Price
Inch	SAE-6	.25 NPTF	K68		K68/S	
Metric	.25 BSPP	.25 BSPP	K68/M		K68/T	



LINE MOUNT BODIES



- Aluminum rated to 3000 psi.
- Ductile Iron rated to 5000 psi.

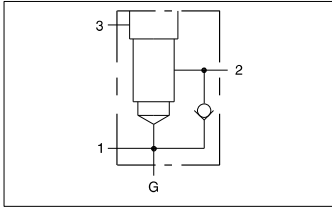

TYPICAL CARTRIDGES USED WITH THIS BODY

PBJB - *** Page 3.07
 PBJC - *** Page 3.09

Cartridge seal type determines check valve seal type.

Instructions for ordering complete cartridge and body assemblies. Page v

Pressure ratings, material specifications. Page 11.02

Body with reverse free flow check and gage port for reducing applications.

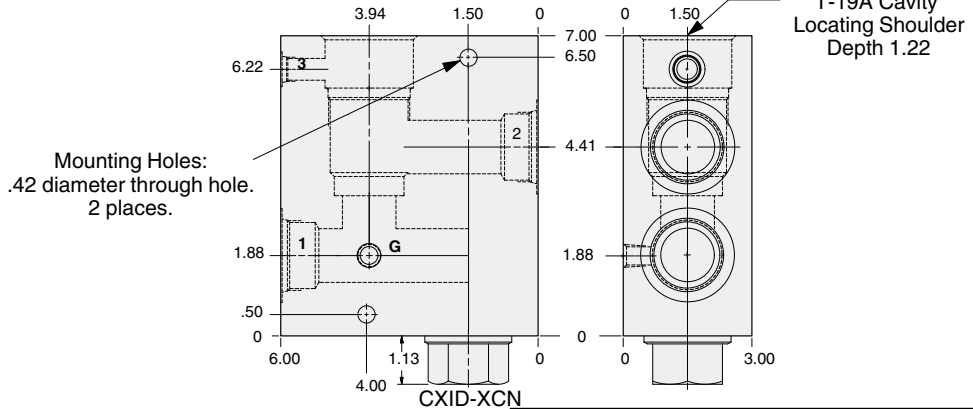

Ports 1 & 2	Port 3	Gage Port	ALUMINUM		DUCTILE IRON	
			Part Number	List Price	Part Number	List Price
.75 NPTF	.25 NPTF	.25 NPTF	K2D		K2D/S	
1.00 NPTF	.25 NPTF	.25 NPTF	K2E		K2E/S	
1.25 NPTF	.25 NPTF	.25 NPTF	K2F		K2F/S	
SAE-12	SAE-6	.25 NPTF	K2L		K2L/S	
SAE-16	SAE-6	.25 NPTF	K2M		K2M/S	
SAE-20	SAE-6	.25 NPTF	K2N		K2N/S	
.75 BSPP	.25 BSPP	.25 BSPP	K2W		K2W/S	
1.00 BSPP	.25 BSPP	.25 BSPP	K2X		K2X/S	
1.25 BSPP	.25 BSPP	.25 BSPP	K2Y		K2Y/S	

S4
T19A

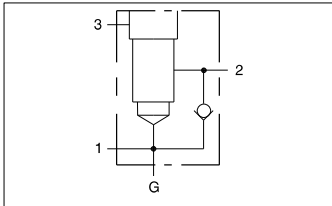

TYPICAL CARTRIDGES USED WITH THIS BODY

PBJB - *** Page 3.11
 PBJC - *** Page 3.13

Cartridge seal type determines check valve seal type.

Instructions for ordering complete cartridge and body assemblies. Page v

Pressure ratings, material specifications. Page 11.02

Body with high capacity port 3 reverse free flow check and gage port for reducing/relieving applications.

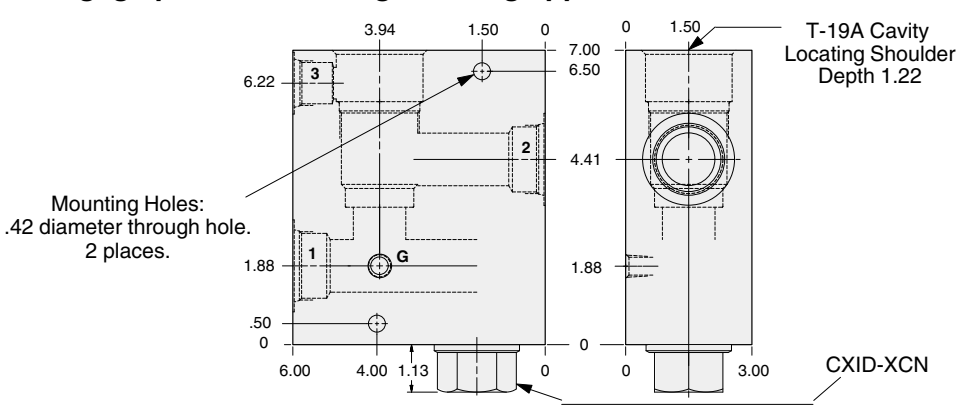

Ports 1 & 2	Port 3	Gage Port	ALUMINUM		DUCTILE IRON	
			Part Number	List Price	Part Number	List Price
.75 NPTF	.75 NPTF	.25 NPTF	K4D		K4D/S	
1.00 NPTF	.75 NPTF	.25 NPTF	K4E		K4E/S	
1.25 NPTF	.75 NPTF	.25 NPTF	K4F		K4F/S	
SAE-12	SAE-12	.25 NPTF	K4L		K4L/S	
SAE-16	SAE-12	.25 NPTF	K4M		K4M/S	
SAE-20	SAE-12	.25 NPTF	K4N		K4N/S	
.75 BSPP	.75 BSPP	.25 BSPP	K4W		K4W/S	
1.00 BSPP	.75 BSPP	.25 BSPP	K4X		K4X/S	
1.25 BSPP	.75 BSPP	.25 BSPP	K4Y		K4Y/S	



LINE MOUNT BODIES



- Aluminum rated to 3000 psi.
- Ductile Iron rated to 5000 psi.

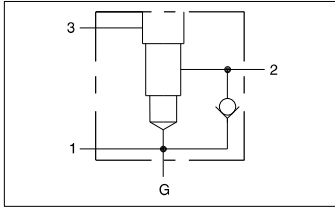

1.25" SAE Code 61 flange port body with reverse free flow check and gage port for reducing applications.

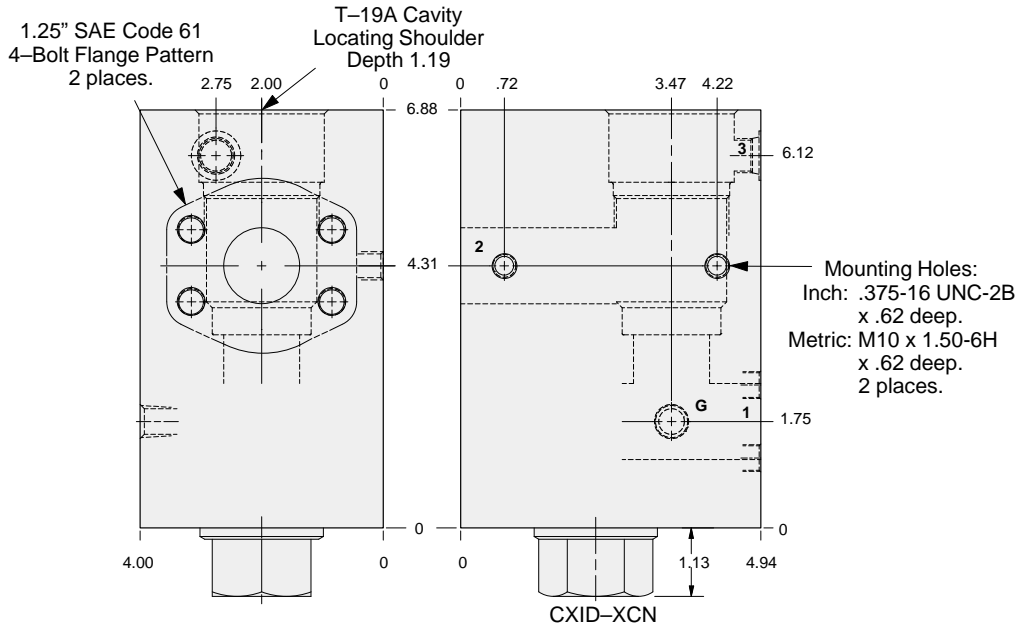

Mounting Hole Dimensions	Port 3	Gage Port	ALUMINUM		DUCTILE IRON	
			Part Number	List Price	Part Number	List Price
Inch	SAE-6	.25 NPTF	K2Q		K2Q/S	
Metric	.25 BSPP	.25 BSPP	K2Q/M		K2Q/T	

TYPICAL CARTRIDGES USED WITH THIS BODY

PBJB - *** Page 3.07
 PBJC - *** Page 3.09

Cartridge seal type determines check valve seal type.

Instructions for ordering complete cartridge and body assemblies. Page v

Pressure ratings, material specifications. Page 11.02

SAE Specifications Page 11.03

S4
T19A

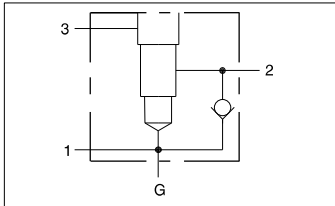

1.25" SAE Code 62 flange port body with reverse free flow check and gage port for reducing applications.

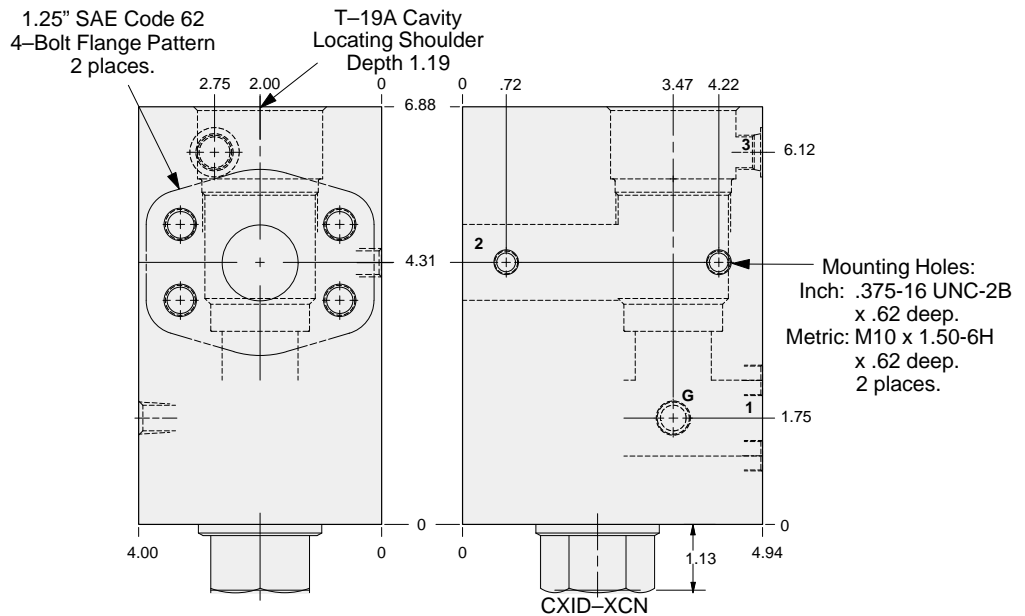

Mounting Hole Dimensions	Port 3	Gage Port	ALUMINUM		DUCTILE IRON	
			Part Number	List Price	Part Number	List Price
Inch	SAE-6	.25 NPTF	K25		K25/S	
Metric	.25 BSPP	.25 BSPP	K25/M		K25/T	

TYPICAL CARTRIDGES USED WITH THIS BODY

PBJB - *** Page 3.07
 PBJC - *** Page 3.09

Cartridge seal type determines check valve seal type.

Instructions for ordering complete cartridge and body assemblies. Page v

Pressure ratings, material specifications. Page 11.02

SAE Specifications Page 11.03



LINE MOUNT BODIES



- Aluminum rated to 3000 psi.
- Ductile Iron rated to 5000 psi.

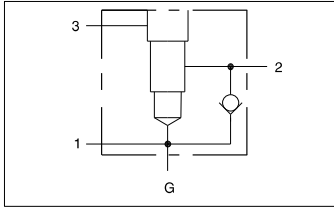

1.50" SAE Code 61 flange port body with reverse free flow check and gage port for reducing applications.

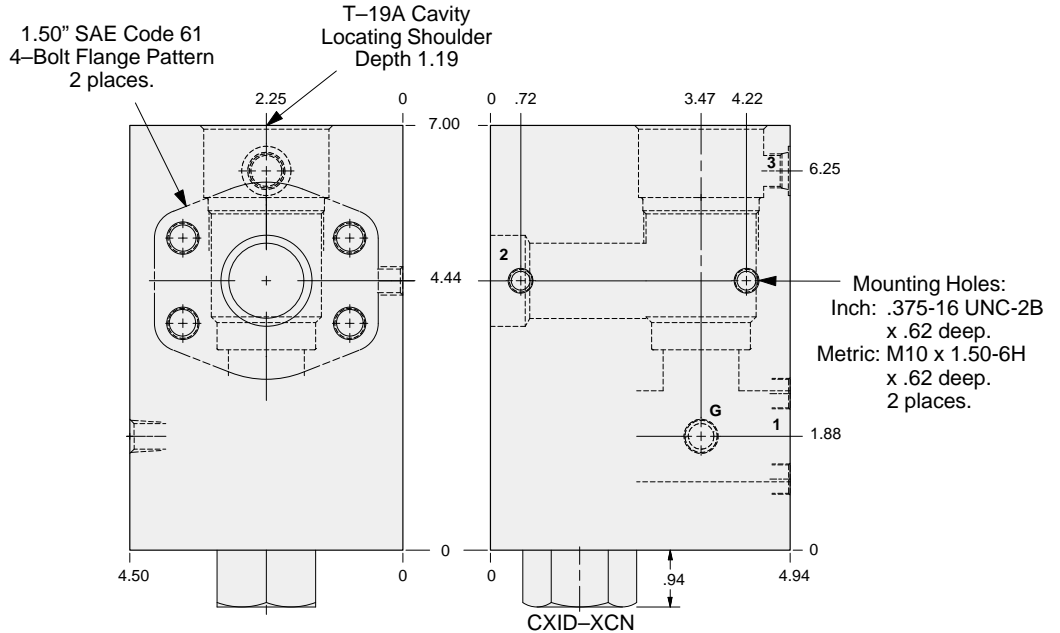

TYPICAL CARTRIDGES USED WITH THIS BODY

PBJB - *** Page 3.07
PBJC - *** Page 3.09

Cartridge seal type determines check valve seal type.

Instructions for ordering complete cartridge and body assemblies. Page v

Pressure ratings, material specifications. Page 11.02

SAE Specifications Page 11.03

Mounting Hole Dimensions	Port 3	Gage Port	ALUMINUM		DUCTILE IRON	
			Part Number	List Price	Part Number	List Price
Inch	SAE-6	.25 NPTF	K2R		K2R/S	
Metric	.25 BSPP	.25 BSPP	K2R/M		K2R/T	

S4
T19A

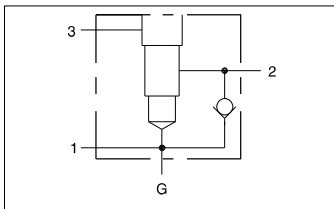

1.50" SAE Code 62 flange port body with reverse free flow check and gage port for reducing applications.

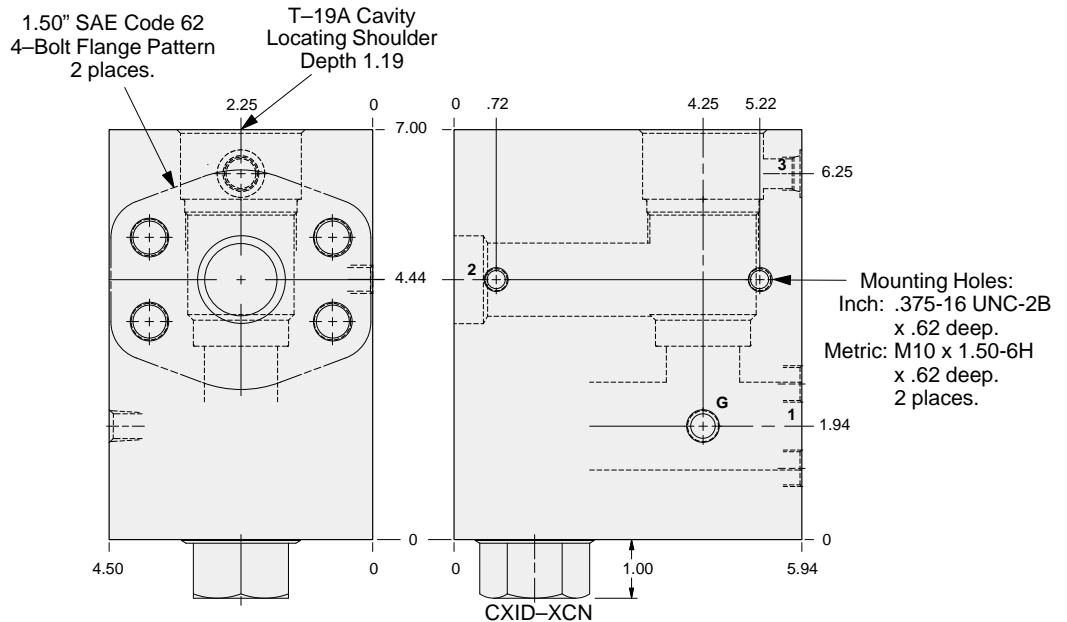

TYPICAL CARTRIDGES USED WITH THIS BODY

PBJB - *** Page 3.07
PBJC - *** Page 3.09

Cartridge seal type determines check valve seal type.

Instructions for ordering complete cartridge and body assemblies. Page v

Pressure ratings, material specifications. Page 11.02

SAE Specifications Page 11.03

Mounting Hole Dimensions	Port 3	Gage Port	ALUMINUM		DUCTILE IRON	
			Part Number	List Price	Part Number	List Price
Inch	SAE-6	.25 NPTF	K26		K26/S	
Metric	.25 BSPP	.25 BSPP	K26/M		K26/T	



LINE MOUNT BODIES



- Aluminum rated to 3000 psi.
- Ductile Iron rated to 5000 psi.

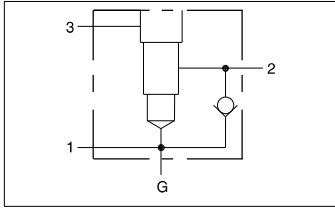

1.50" SAE Code 61 flange port body with high capacity port 3 reverse free flow check and gage port for reducing/relieving applications.

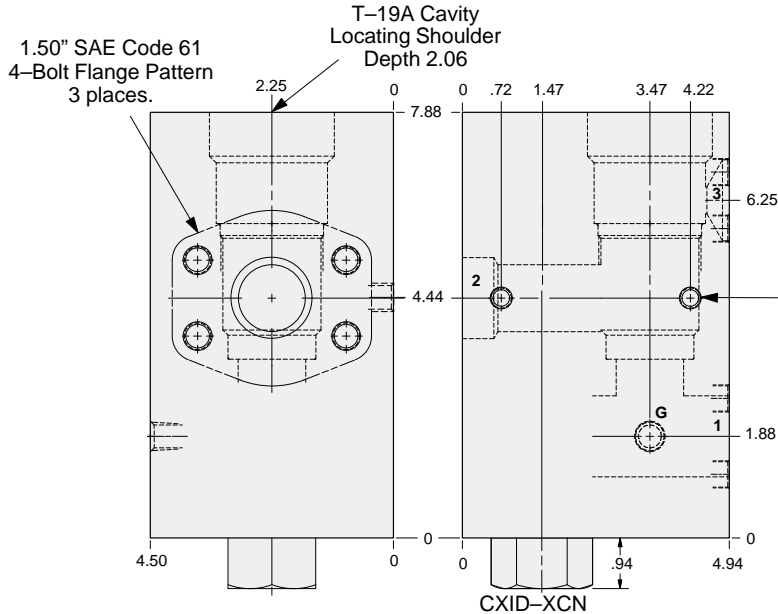

Mounting Holes:
 Inch: .375-16 UNC-2B
 x .62 deep.
 Metric: M10 x 1.50-6H
 x .62 deep.
 2 places.

TYPICAL CARTRIDGES USED WITH THIS BODY

- PPJB - *** Page 3.11
- PPJC - *** Page 3.13

Cartridge seal type determines check valve seal type.

Instructions for ordering complete cartridge and body assemblies. Page v

Pressure ratings, material specifications. Page 11.02

SAE Specifications Page 11.03

Mounting Hole Dimensions	Gage Port	ALUMINUM		DUCTILE IRON	
		Part Number	List Price	Part Number	List Price
Inch	.25 NPTF	K4R		K4R/S	
Metric	.25 BSPP	K4R/M		K4R/T	

S4
T19A

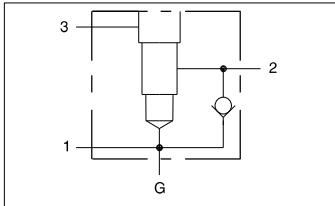

1.50" SAE Code 62 flange port body with high capacity port 3 reverse free flow check and gage port for reducing/relieving applications.

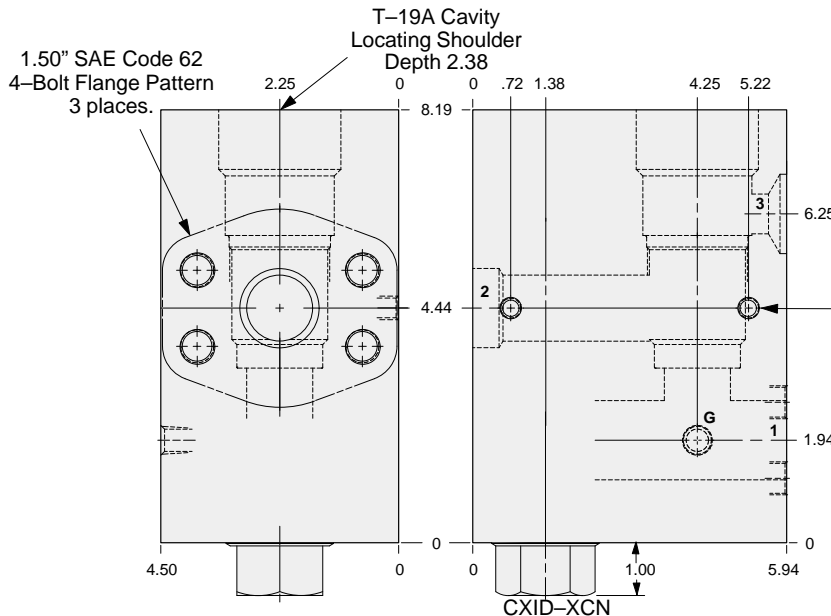

Mounting Holes:
 Inch: .375-16 UNC-2B
 x .62 deep.
 Metric: M10 x 1.50-6H
 x .62 deep.
 2 places.

TYPICAL CARTRIDGES USED WITH THIS BODY

- PPJB - *** Page 3.11
- PPJC - *** Page 3.13

Cartridge seal type determines check valve seal type.

Instructions for ordering complete cartridge and body assemblies. Page v

Pressure ratings, material specifications. Page 11.02

SAE Specifications Page 11.03

Mounting Hole Dimensions	Gage Port	ALUMINUM		DUCTILE IRON	
		Part Number	List Price	Part Number	List Price
Inch	.25 NPTF	K46		K46/S	
Metric	.25 BSPP	K46/M		K46/T	



LINE MOUNT BODIES



- Aluminum rated to 3000 psi.
- Ductile Iron rated to 5000 psi.

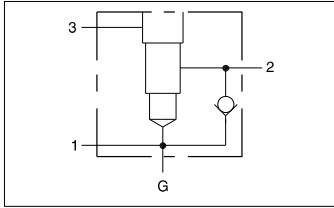

TYPICAL CARTRIDGES USED WITH THIS BODY

PPJB - *** Page 3.11
 PPJC - *** Page 3.13

Cartridge seal type determines check valve seal type.

Instructions for ordering complete cartridge and body assemblies. Page v

Pressure ratings, material specifications. Page 11.02

SAE Specifications Page 11.03

2.00" SAE Code 61 flange port body with high capacity port 3 reverse free flow check and gage port for reducing/relieving applications.

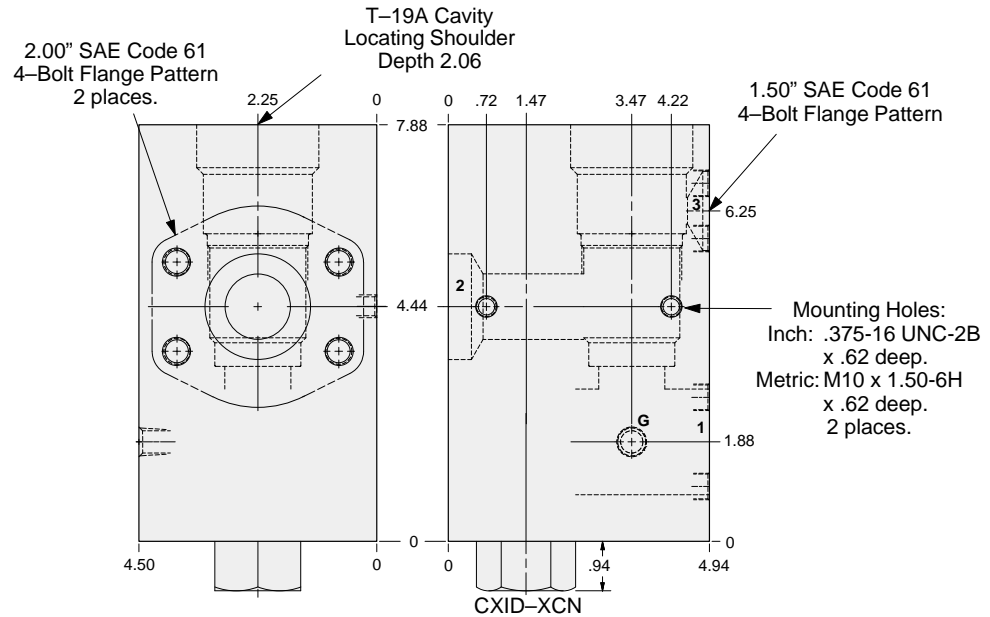

Mounting Hole Dimensions	Port 3 SAE Code 61	Gage Port	ALUMINUM		DUCTILE IRON	
			Part Number	List Price	Part Number	List Price
Inch	1.50"	.25 NPTF	K4S		K4S/S	
Metric	1.50"	.25 BSPP	K4S/M		K4S/T	

S4
T19A

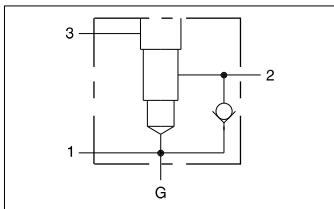

TYPICAL CARTRIDGES USED WITH THIS BODY

PPJB - *** Page 3.11
 PPJC - *** Page 3.13

Cartridge seal type determines check valve seal type.

Instructions for ordering complete cartridge and body assemblies. Page v

Pressure ratings, material specifications. Page 11.02

SAE Specifications Page 11.03

2.00" SAE Code 62 flange port body with high capacity port 3 reverse free flow check and gage port for reducing/relieving applications.

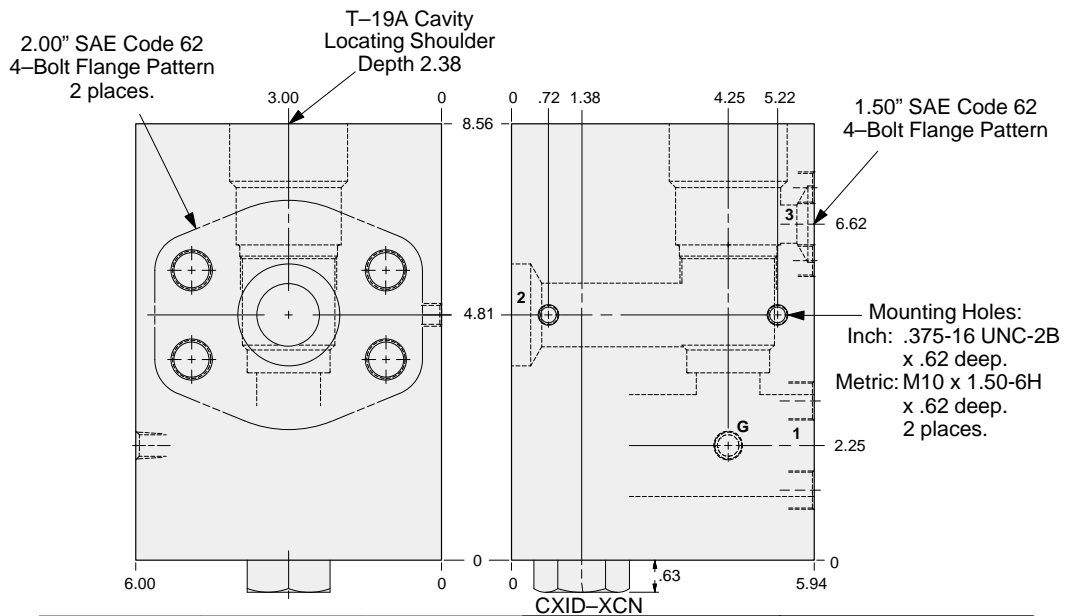

Mounting Hole Dimensions	Port 3 SAE Code 62	Gage Port	ALUMINUM		DUCTILE IRON	
			Part Number	List Price	Part Number	List Price
Inch	1.50"	.25 NPTF	K48		K48/S	
Metric	1.50"	.25 BSPP	K48/M		K48/T	



LINE MOUNT BODIES



- Aluminum rated to 3000 psi.
- Ductile Iron rated to 5000 psi.

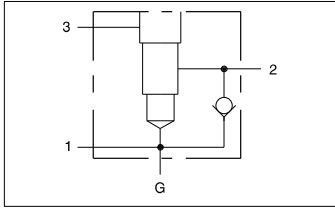

2.00" SAE Code 61 flange port body with reverse free flow check and gage port for reducing applications.

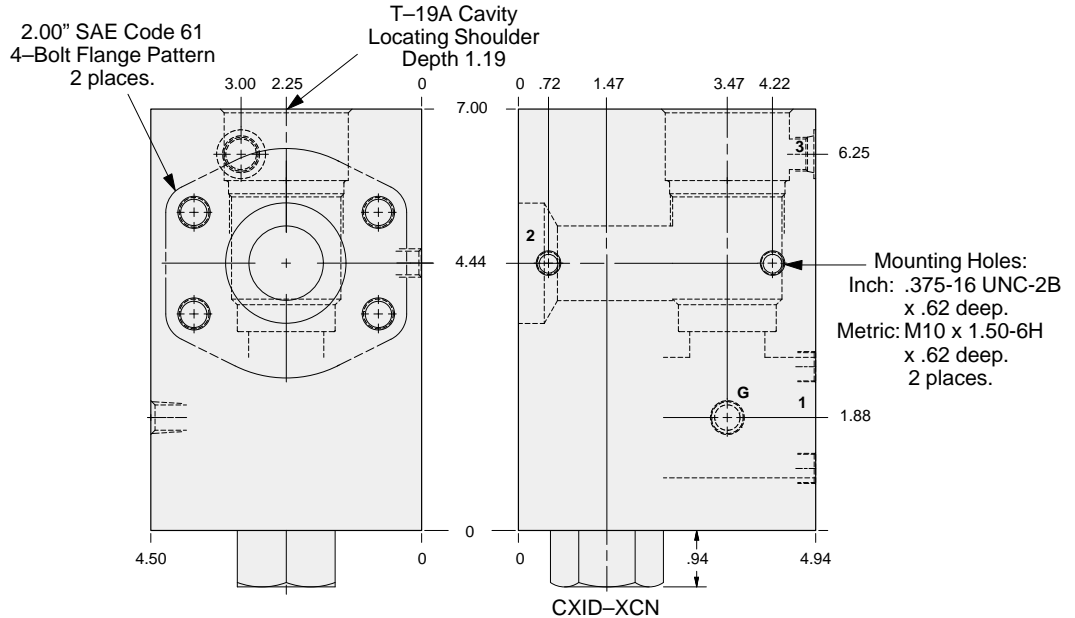

TYPICAL CARTRIDGES USED WITH THIS BODY

PBJB - *** Page 3.07
 PBJC - *** Page 3.09

Cartridge seal type determines check valve seal type.

Instructions for ordering complete cartridge and body assemblies. Page v

Pressure ratings, material specifications. Page 11.02

SAE Specifications Page 11.03

Mounting Hole Dimensions	Port 3	Gage Port	ALUMINUM		DUCTILE IRON	
			Part Number	List Price	Part Number	List Price
Inch	SAE-6	.25 NPTF	K2S		K2S/S	
Metric	.25 BSPP	.25 BSPP	K2S/M		K2S/T	

S4
T19A

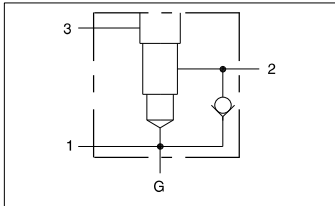

2.00" SAE Code 62 flange port body with reverse free flow check and gage port for reducing applications.

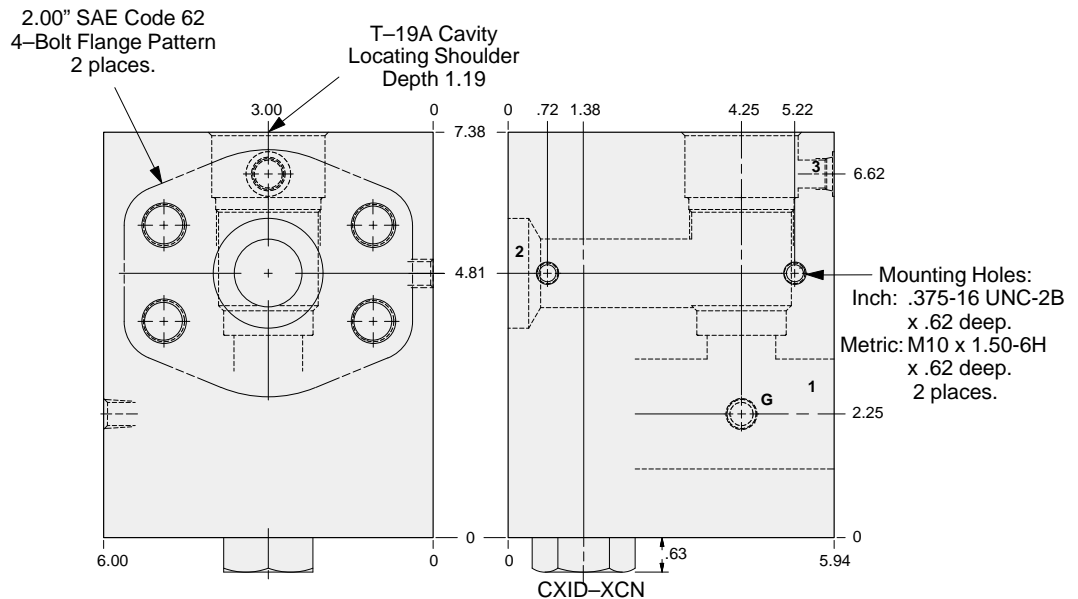

TYPICAL CARTRIDGES USED WITH THIS BODY

PBJB - *** Page 3.07
 PBJC - *** Page 3.09

Cartridge seal type determines check valve seal type.

Instructions for ordering complete cartridge and body assemblies. Page v

Pressure ratings, material specifications. Page 11.02

SAE Specifications Page 11.03

Mounting Hole Dimensions	Port 3	Gage Port	ALUMINUM		DUCTILE IRON	
			Part Number	List Price	Part Number	List Price
Inch	SAE-6	.25 NPTF	K28		K28/S	
Metric	.25 BSPP	.25 BSPP	K28/M		K28/T	



LINE MOUNT BODIES



- Aluminum rated to 3000 psi.
- Ductile Iron rated to 5000 psi.

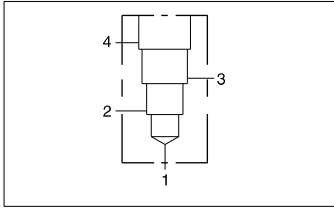

90 degree body.

T-24A Cavity
Locating Shoulder
Depth 2.00

Mounting Holes:
.42 diameter through hole.
2 places.

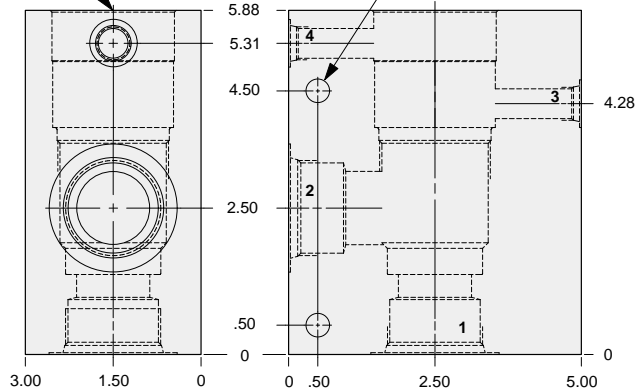

TYPICAL CARTRIDGES USED WITH THIS BODY

RVID - ***	Page 1.21
CWIA - ***	Page 4.19
CWIG - ***	Page 4.21
CVIV - ***	Page 4.23

Instructions for ordering complete cartridge and body assemblies. Page v

Pressure ratings, material specifications. Page 11.02

Ports 1 & 2	Ports 3 & 4	ALUMINUM		DUCTILE IRON	
		Part Number	List Price	Part Number	List Price
1.00 NPTF	.25 NPTF	QCE		QCE/S	
1.25 NPTF	.25 NPTF	QCF		QCF/S	
SAE-16	SAE-6	QCM		QCM/S	
SAE-20	SAE-6	QCN		QCN/S	
1.00 BSPP	.25 BSPP	QCX		QCX/S	
1.25 BSPP	.25 BSPP	QCY		QCY/S	

S4
T24A

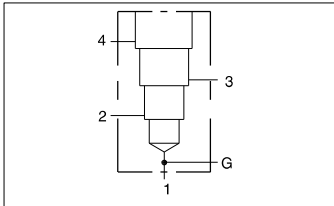

90 degree body with high capacity port 3 and gage port.

T-24A Cavity
Locating Shoulder
Depth 2.00

Mounting Holes:
.42 diameter through hole.
2 places.

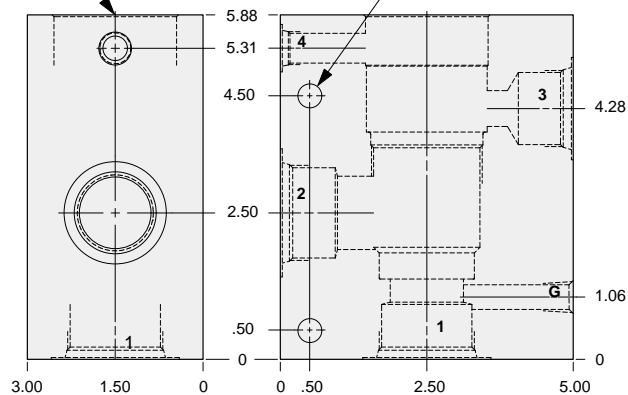

TYPICAL CARTRIDGES USED WITH THIS BODY

PVJA - ***	Page 3.15
PVJB - ***	Page 3.17
FVFA - ***	Page 6.05

Instructions for ordering complete cartridge and body assemblies. Page v

Pressure ratings, material specifications. Page 11.02

Ports 1 & 2	Port 3	Port 4	Gage Port	ALUMINUM		DUCTILE IRON	
				Part Number	List Price	Part Number	List Price
1.00 NPTF	1.00 NPTF	.25 NPTF	.25 NPTF	QAE		QAE/S	
1.25 NPTF	1.00 NPTF	.25 NPTF	.25 NPTF	QAF		QAF/S	
SAE-16	SAE-16	SAE-6	.25 NPTF	QAM		QAM/S	
SAE-20	SAE-16	SAE-6	.25 NPTF	QAN		QAN/S	
1.00 BSPP	1.00 BSPP	.25 BSPP	.25 BSPP	QAX		QAX/S	
1.25 BSPP	1.00 BSPP	.25 BSPP	.25 BSPP	QAY		QAY/S	



LINE MOUNT BODIES



- Aluminum rated to 3000 psi.
- Ductile Iron rated to 5000 psi.

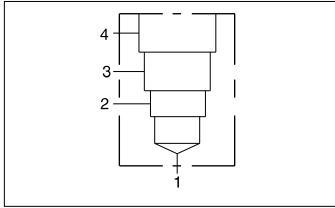

90 degree 1.25" SAE Code 61 flange port body.

1.25" SAE Code 61
4-Bolt Flange Pattern
2 places.

T-24A Cavity
Locating Shoulder
Depth 2.00

Mounting Holes:
(opposite side)
Inch: .375-16 UNC-2B
x .62 deep.
Metric: M10 x 1.50-6H
x .62 deep.
2 places.

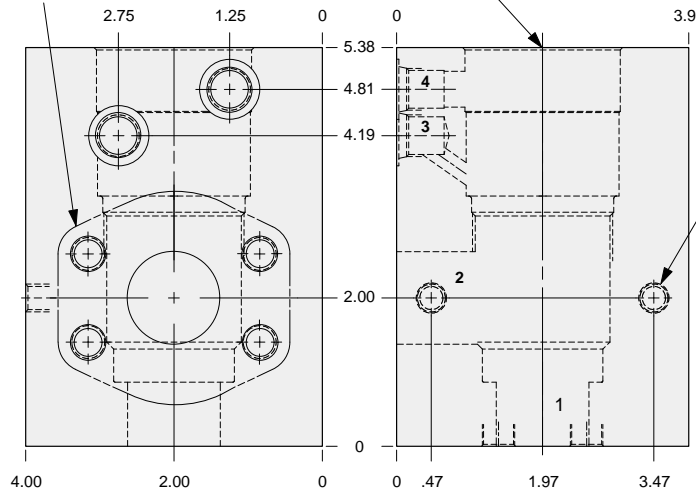

TYPICAL CARTRIDGES USED WITH THIS BODY

RVID - ***	Page 1.21
CWIA - ***	Page 4.19
CWIG - ***	Page 4.21
CVIV - ***	Page 4.23

Instructions for ordering complete cartridge and body assemblies. Page v

Pressure ratings, material specifications. Page 11.02

SAE Specifications Page 11.03

Mounting Hole Dimensions	Ports 3 & 4	ALUMINUM		DUCTILE IRON	
		Part Number	List Price	Part Number	List Price
Inch	SAE-6	QCQ		QCQ/S	
Metric	.25 BSPP	QCQ/M		QCQ/T	

S4
T24A

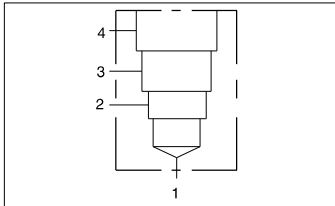

90 degree 1.25" SAE Code 62 flange port body.

1.25" SAE Code 62
4-Bolt Flange Pattern
2 places.

T-24A Cavity
Locating Shoulder
Depth 2.00

Mounting Holes:
(opposite side)
Inch: .375-16 UNC-2B
x .62 deep.
Metric: M10 x 1.50-6H
x .62 deep.
2 places.

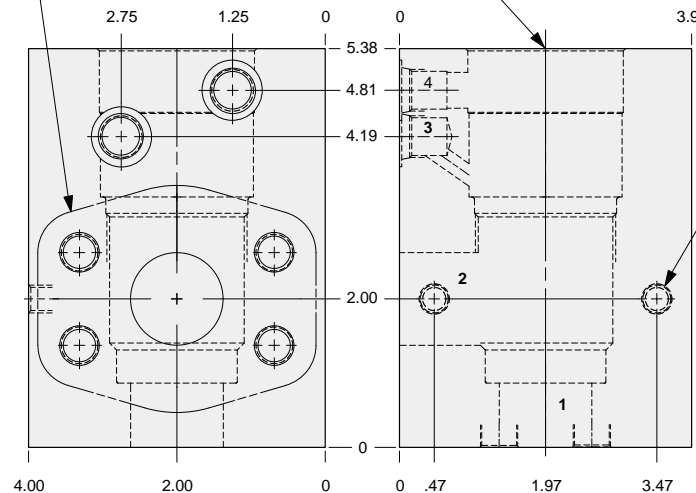

TYPICAL CARTRIDGES USED WITH THIS BODY

RVID - ***	Page 1.21
CWIA - ***	Page 4.19
CWIG - ***	Page 4.21
CVIV - ***	Page 4.23

Instructions for ordering complete cartridge and body assemblies. Page v

Pressure ratings, material specifications. Page 11.02

SAE Specifications Page 11.03

Mounting Hole Dimensions	Ports 3 & 4	ALUMINUM		DUCTILE IRON	
		Part Number	List Price	Part Number	List Price
Inch	SAE-6	QC5		QC5/S	
Metric	.25 BSPP	QC5/M		QC5/T	



LINE MOUNT BODIES

- Aluminum rated to 3000 psi.
- Ductile Iron rated to 5000 psi.

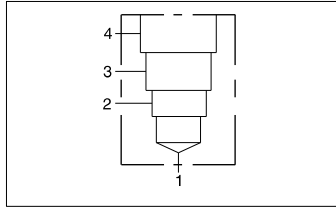

90 degree 1.50" SAE Code 61 flange port body.

1.50" SAE Code 61
4-Bolt Flange Pattern
2 places.

T-24A Cavity
Locating Shoulder
Depth 2.06

Mounting Holes:
(opposite side)
Inch: .375-16 UNC-2B
x .62 deep.
Metric: M10 x 1.50-6H
x .62 deep.
2 places.

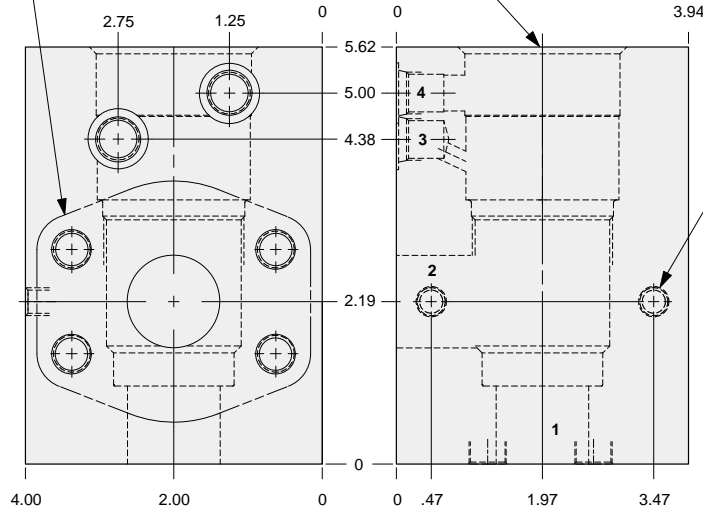

Mounting Hole Dimensions	Ports 3 & 4	ALUMINUM		DUCTILE IRON	
		Part Number	List Price	Part Number	List Price
Inch	SAE-6	QCR		QCR/S	
Metric	.25 BSPP	QCR/M		QCR/T	

S4
T24A

TYPICAL CARTRIDGES USED WITH THIS BODY

- RVID - *** Page 1.21
CWIA - *** Page 4.19
CWIG - *** Page 4.21
CVIV - *** Page 4.23

Instructions for ordering complete cartridge and body assemblies. Page v

Pressure ratings, material specifications. Page 11.02

SAE Specifications Page 11.03

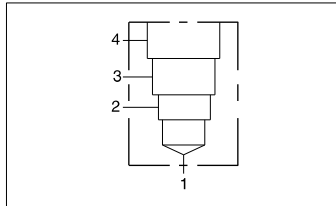

90 degree 1.50" SAE Code 62 flange port body.

1.50" SAE Code 62
4-Bolt Flange Pattern
2 places.

T-24A Cavity
Locating Shoulder
Depth 2.06

Mounting Holes:
(opposite side)
Inch: .375-16 UNC-2B
x .62 deep.
Metric: M10 x 1.50-6H
x .62 deep.
2 places.

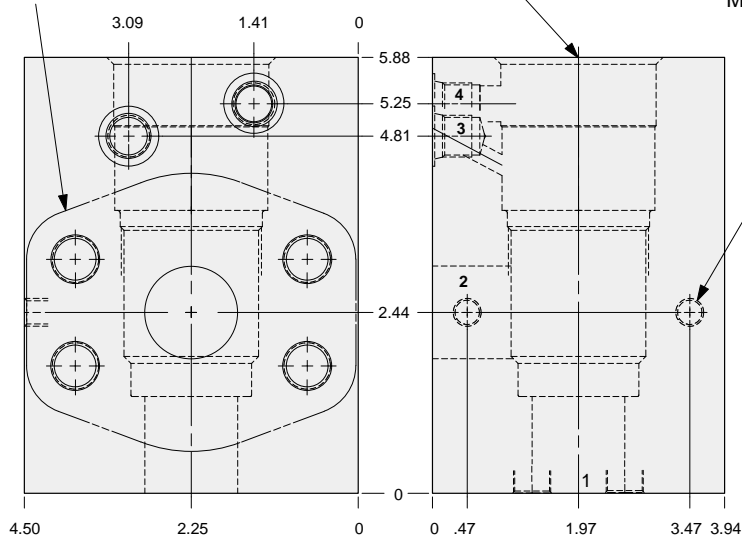

Mounting Hole Dimensions	Ports 3 & 4	ALUMINUM		DUCTILE IRON	
		Part Number	List Price	Part Number	List Price
Inch	SAE-6	QC6		QC6/S	
Metric	.25 BSPP	QC6/M		QC6/T	

TYPICAL CARTRIDGES USED WITH THIS BODY

- RVID - *** Page 1.21
CWIA - *** Page 4.19
CWIG - *** Page 4.21
CVIV - *** Page 4.23

Instructions for ordering complete cartridge and body assemblies. Page v

Pressure ratings, material specifications. Page 11.02

SAE Specifications Page 11.03



LINE MOUNT BODIES

- Aluminum rated to 3000 psi.
- Ductile Iron rated to 5000 psi.



90 degree 2.00" SAE Code 61 flange port body.

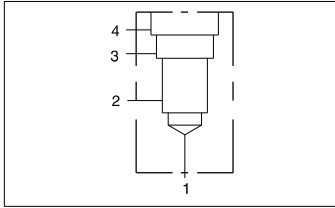

2.00" SAE Code 61
4-Bolt Flange Pattern
2 places.

T-24A Cavity
Locating Shoulder
Depth 2.06

Mounting Holes:
(opposite side)
Inch: .375-16 UNC-2B
x .62 deep.
Metric: M10 x 1.50-6H
x .75 deep.
2 places.

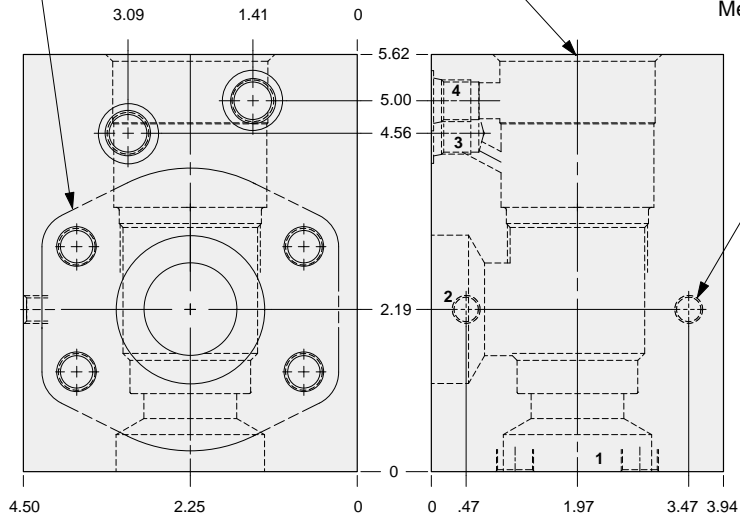

TYPICAL CARTRIDGES USED WITH THIS BODY

RVID - ***	Page 1.21
CWIA - ***	Page 4.19
CWIG - ***	Page 4.21
CVIV - ***	Page 4.23

Instructions for ordering complete cartridge and body assemblies. Page v

Pressure ratings, material specifications. Page 11.02

SAE Specifications Page 11.03

Mounting Hole Dimensions	Ports 3 & 4	ALUMINUM		DUCTILE IRON	
		Part Number	List Price	Part Number	List Price
Inch	SAE-6	QCS		QCS/S	
Metric	.25 BSPP	QCS/M		QCS/T	

S4
T24A

90 degree 2.00" SAE Code 62 flange port body.

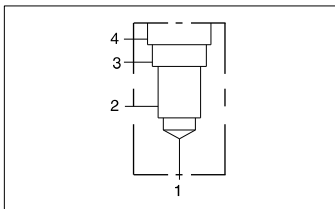

2.00" SAE Code 62
4-Bolt Flange Pattern
2 places.

T-24A Cavity
Locating Shoulder
Depth 2.31

Mounting Holes:
(opposite side)
Inch: .375-16 UNC-2B
x .62 deep.
Metric: M10 x 1.50-6H
x .75 deep.
2 places.

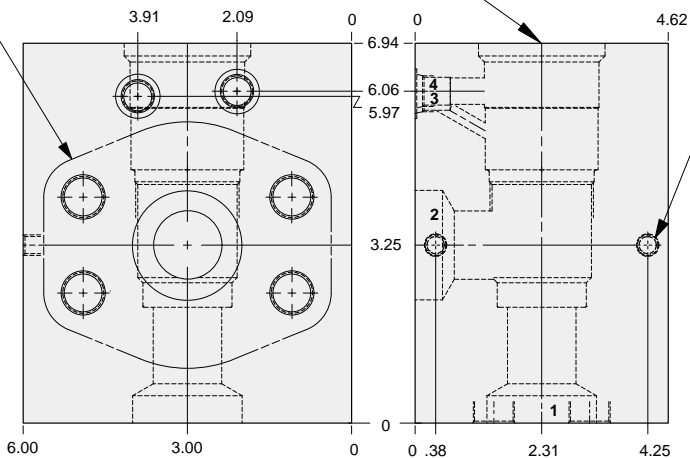

TYPICAL CARTRIDGES USED WITH THIS BODY

RVID - ***	Page 1.21
CWIA - ***	Page 4.19
CWIG - ***	Page 4.21
CVIV - ***	Page 4.23

Instructions for ordering complete cartridge and body assemblies. Page v

Pressure ratings, material specifications. Page 11.02

SAE Specifications Page 11.03

Mounting Hole Dimensions	Ports 3 & 4	ALUMINUM		DUCTILE IRON	
		Part Number	List Price	Part Number	List Price
Inch	SAE-6	QC8		QC8/S	
Metric	.25 BSPP	QC8/M		QC8/T	



LINE MOUNT BODIES



- Aluminum rated to 3000 psi.
- Ductile Iron rated to 5000 psi.

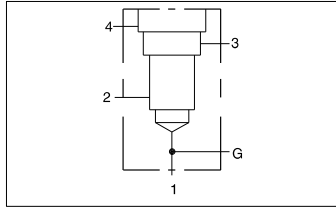

90 degree 1.25" SAE Code 61 high capacity flange port body with gage port.

1.25" SAE Code 61
4-Bolt Flange Pattern
3 places.

T-24A Cavity
Locating Shoulder
Depth 2.00

Mounting Holes:
(opposite side)
Inch: .375-16 UNC-2B
x .62 deep.
Metric: M10 x 1.50-6H
x .75 deep.
2 places.

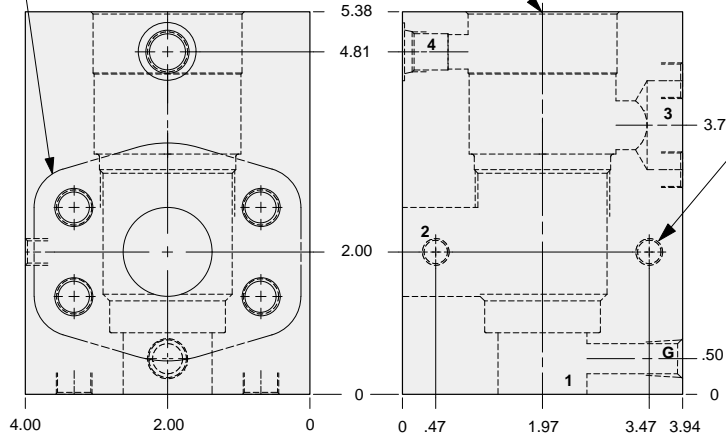

TYPICAL CARTRIDGES USED WITH THIS BODY

- PVJA - *** Page 3.15
PVJB - *** Page 3.17
FVFA - *** Page 6.05

Instructions for ordering complete cartridge and body assemblies. Page v

Pressure ratings, material specifications. Page 11.02

SAE Specifications Page 11.03

Mounting Hole Dimensions	Port 4	Gage Port	ALUMINUM		DUCTILE IRON	
			Part Number	List Price	Part Number	List Price
Inch	SAE-6	.25 NPTF	QAQ		QAQ/S	
Metric	.25 BSPP	.25 BSPP	QAQ/M		QAQ/T	

S4
T24A

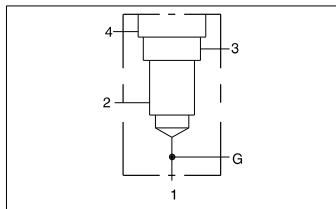

90 degree 1.25" SAE Code 62 high capacity flange port body with gage port.

1.25" SAE Code 62
4-Bolt Flange Pattern
3 places.

T-24A Cavity
Locating Shoulder
Depth 2.00

Mounting Holes:
(opposite side)
Inch: .375-16 UNC-2B
x .62 deep.
Metric: M10 x 1.50-6H
x .75 deep.
2 places.

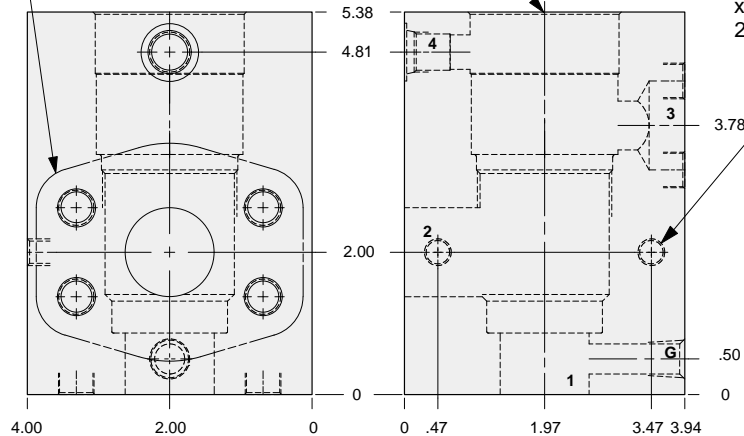

TYPICAL CARTRIDGES USED WITH THIS BODY

- PVJA - *** Page 3.15
PVJB - *** Page 3.17
FVFA - *** Page 6.05

Instructions for ordering complete cartridge and body assemblies. Page v

Pressure ratings, material specifications. Page 11.02

SAE Specifications Page 11.03

Mounting Hole Dimensions	Port 4	Gage Port	ALUMINUM		DUCTILE IRON	
			Part Number	List Price	Part Number	List Price
Inch	SAE-6	.25 NPTF	QA5		QA5/S	
Metric	.25 BSPP	.25 BSPP	QA5/M		QA5/T	



LINE MOUNT BODIES



- Aluminum rated to 3000 psi.
- Ductile Iron rated to 5000 psi.

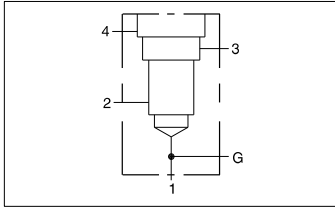

90 degree 1.50" SAE Code 61 high capacity flange port body with gage port.

1.50" SAE Code 61
4-Bolt Flange Pattern
3 places.

T-24A Cavity
Locating Shoulder
Depth 2.06

Mounting Holes:
(opposite side)
Inch: .375-16 UNC-2B
x .62 deep.
Metric: M10 x 1.50-6H
x .75 deep.
2 places.

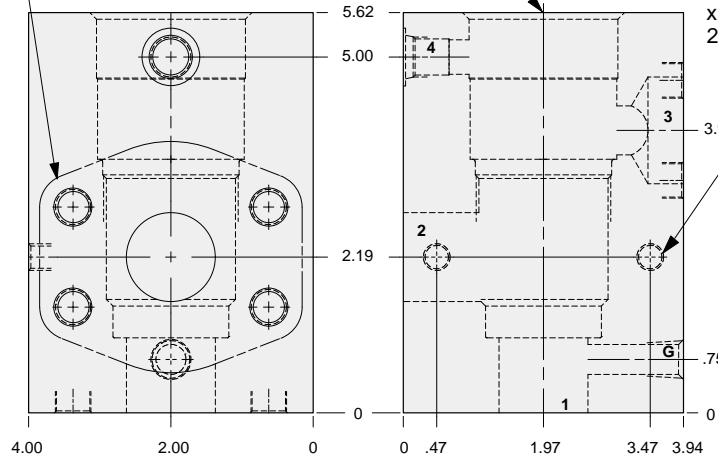

TYPICAL CARTRIDGES USED WITH THIS BODY

- PVJA - *** Page 3.15
PVJB - *** Page 3.17
FVFA - *** Page 6.05

Instructions for ordering complete cartridge and body assemblies. Page v

Pressure ratings, material specifications. Page 11.02

SAE Specifications Page 11.03

Mounting Hole Dimensions	Port 4	Gage Port	ALUMINUM		DUCTILE IRON	
			Part Number	List Price	Part Number	List Price
Inch	SAE-6	.25 NPTF	QAR		QAR/S	
Metric	.25 BSPP	.25 BSPP	QAR/M		QAR/T	

S4
T24A

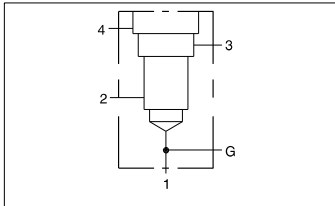

90 degree 1.50" SAE Code 62 high capacity flange port body with gage port.

1.50" SAE Code 62
4-Bolt Flange Pattern
3 places.

T-24A Cavity
Locating Shoulder
Depth 2.31

Mounting Holes:
(opposite side)
Inch: .375-16 UNC-2B
x .62 deep.
Metric: M10 x 1.50-6H
x .75 deep.
2 places.

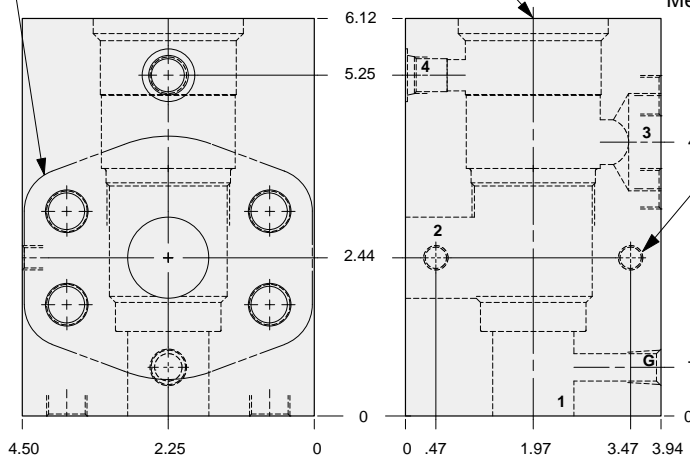

TYPICAL CARTRIDGES USED WITH THIS BODY

- PVJA - *** Page 3.15
PVJB - *** Page 3.17
FVFA - *** Page 6.05

Instructions for ordering complete cartridge and body assemblies. Page v

Pressure ratings, material specifications. Page 11.02

SAE Specifications Page 11.03

Mounting Hole Dimensions	Port 4	Gage Port	ALUMINUM		DUCTILE IRON	
			Part Number	List Price	Part Number	List Price
Inch	SAE-6	.25 NPTF	QA6		QA6/S	
Metric	.25 BSPP	.25 BSPP	QA6/M		QA6/T	



LINE MOUNT BODIES



- Aluminum rated to 3000 psi.
- Ductile Iron rated to 5000 psi.

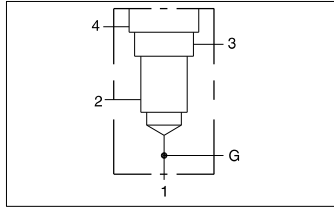

90 degree 2.00" SAE Code 61 high capacity flange port body with gage port.

2.00" SAE Code 61
4-Bolt Flange Pattern
2 places.

T-24A Cavity
Locating Shoulder
Depth 2.06

Mounting Holes:
(opposite side)
Inch: .375-16 UNC-2B
x .62 deep.
Metric: M10 x 1.50-6H
x .75 deep.
2 places.

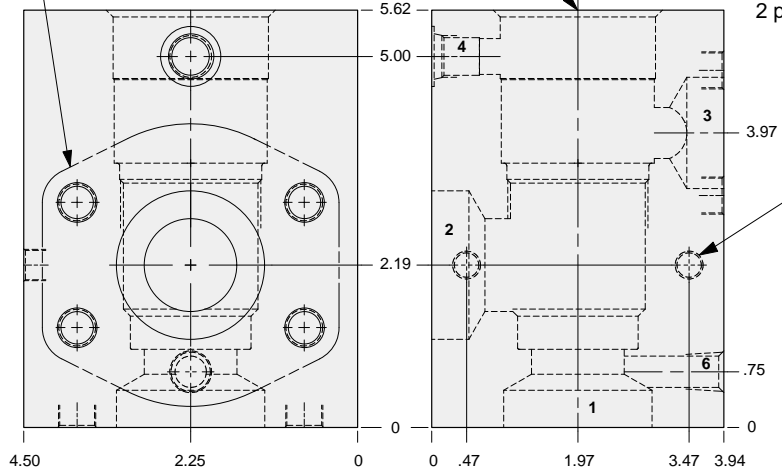

TYPICAL CARTRIDGES USED WITH THIS BODY

- PVJA - *** Page 3.15
PVJB - *** Page 3.17
FVFA - *** Page 6.05

Instructions for ordering complete cartridge and body assemblies. Page v

Pressure ratings, material specifications. Page 11.02

SAE Specifications Page 11.03

Mounting Hole Dimensions	Port 3 SAE Code 61	Port 4	Gage Port	ALUMINUM		DUCTILE IRON	
				Part Number	List Price	Part Number	List Price
Inch	1.50"	SAE-6	.25 NPTF	QAS		QAS/S	
Metric	1.50"	.25 BSPP	.25 BSPP	QAS/M		QAS/T	

S4
T24A

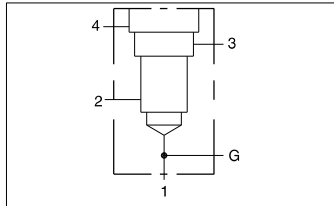

90 degree 2.00" SAE Code 62 high capacity flange port body with gage port.

2.00" SAE Code 62
4-Bolt Flange Pattern
2 places.

T-24A Cavity
Locating Shoulder
Depth 2.31

Mounting Holes:
(opposite side)
Inch: .375-16 UNC-2B
x .62 deep.
Metric: M10 x 1.50-6H
x .75 deep.
2 places.

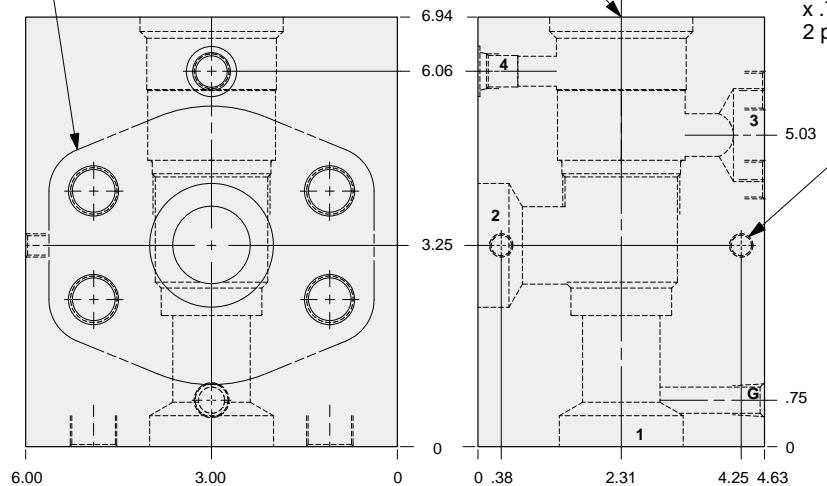

TYPICAL CARTRIDGES USED WITH THIS BODY

- PVJA - *** Page 3.15
PVJB - *** Page 3.17
FVFA - *** Page 6.05

Instructions for ordering complete cartridge and body assemblies. Page v

Pressure ratings, material specifications. Page 11.02

SAE Specifications Page 11.03

Mounting Hole Dimensions	Port 3 SAE Code 62	Port 4	Gage Port	ALUMINUM		DUCTILE IRON	
				Part Number	List Price	Part Number	List Price
Inch	1.50"	SAE-6	.25 NPTF	QA8		QA8/S	
Metric	1.50"	.25 BSPP	.25 BSPP	QA8/M		QA8/T	



LINE MOUNT BODIES



- Aluminum rated to 3000 psi.
- Ductile Iron rated to 5000 psi.

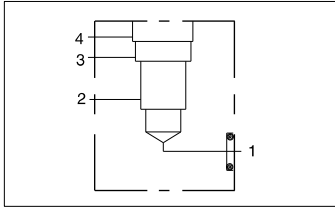

Direct mount 1.00" SAE Code 62 body.

1.00" SAE Code 62
4-Bolt Flange Pattern
2 places.
2 holes tapped
4 holes through

T-24A Cavity
Locating Shoulder
Depth 2.00

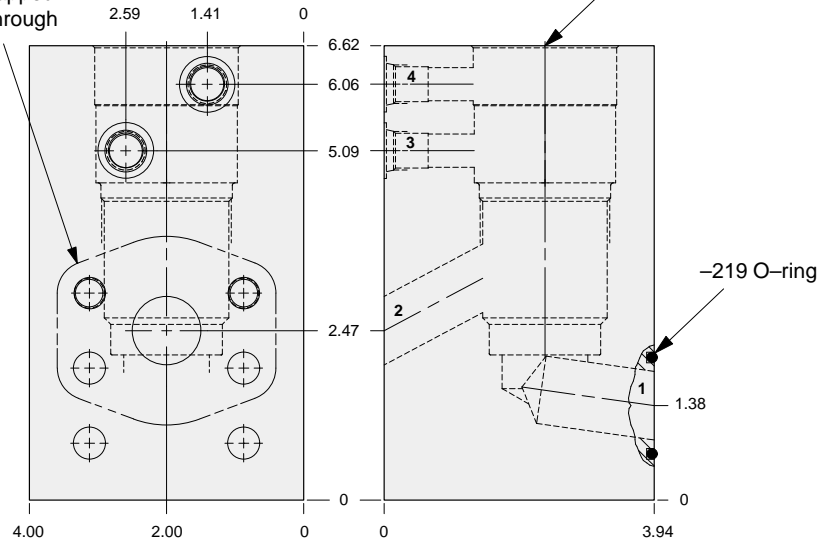

TYPICAL CARTRIDGES USED WITH THIS BODY

- RVID - *** Page 1.21
CWIA - *** Page 4.19
CWIG - *** Page 4.21
CVIV - *** Page 4.23

Cartridge seal type determines O-ring type.

Instructions for ordering complete cartridge and body assemblies. Page v

Pressure ratings, material specifications. Page 11.02

SAE Specifications Page 11.03

S4
T24A

Mounting Hole Dimensions	Ports 3 & 4	ALUMINUM		DUCTILE IRON	
		Part Number	List Price	Part Number	List Price
Inch	SAE-6	WGY		WGY/S	
Metric	.25 BSPP	WGY/M		WGY/T	

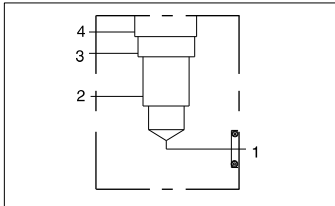

Direct mount 1.25" SAE Code 62 body.

1.25" SAE Code 62
4-Bolt Flange Pattern
2 places.
2 holes tapped
4 holes through

T-24A Cavity
Locating Shoulder
Depth 2.00

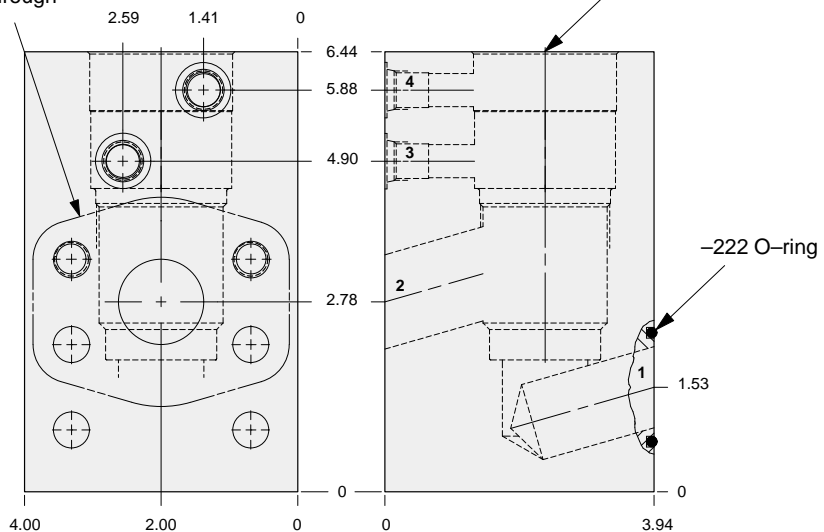

TYPICAL CARTRIDGES USED WITH THIS BODY

- RVID - *** Page 1.21
CWIA - *** Page 4.19
CWIG - *** Page 4.21
CVIV - *** Page 4.23

Cartridge seal type determines O-ring type.

Instructions for ordering complete cartridge and body assemblies. Page v

Pressure ratings, material specifications. Page 11.02

SAE Specifications Page 11.03

Mounting Hole Dimensions	Ports 3 & 4	ALUMINUM		DUCTILE IRON	
		Part Number	List Price	Part Number	List Price
Inch	SAE-6	WGZ		WGZ/S	
Metric	.25 BSPP	WGZ/M		WGZ/T	



LINE MOUNT BODIES



- Aluminum rated to 3000 psi.
- Ductile Iron rated to 5000 psi.

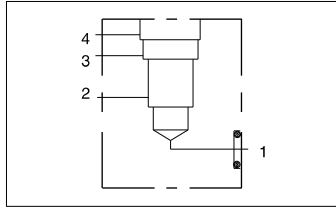

Direct mount 1.50" SAE Code 62 body.

1.50" SAE Code 62
4-Bolt Flange Pattern
2 places.
2 holes tapped
4 holes through

T-24A Cavity
Locating Shoulder
Depth 2.03

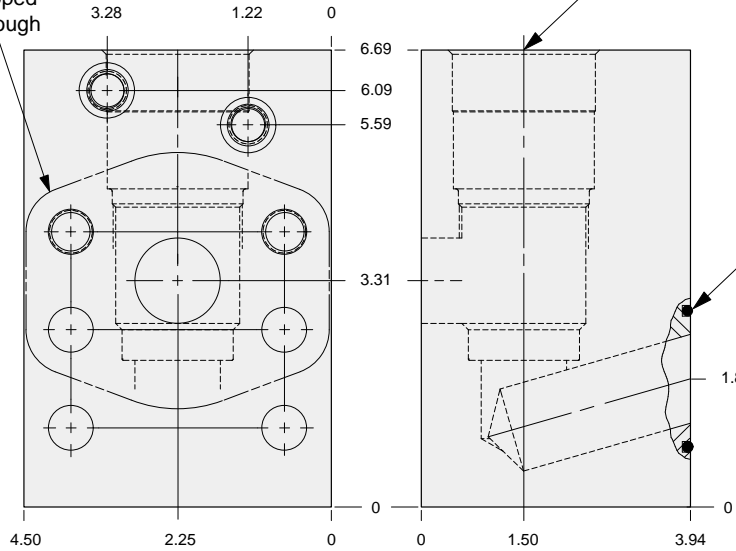

TYPICAL CARTRIDGES USED WITH THIS BODY

RVID - ***	Page 1.21
CWIA - ***	Page 4.19
CWIG - ***	Page 4.21
CVIV - ***	Page 4.23

Cartridge seal type determines O-ring type.

Instructions for ordering complete cartridge and body assemblies. Page v

Pressure ratings, material specifications. Page 11.02

SAE Specifications Page 11.03

Mounting Hole Dimensions	Ports 3 & 4	ALUMINUM		DUCTILE IRON	
		Part Number	List Price	Part Number	List Price
Inch	SAE-6	WGT		WGT/S	
Metric	.25 BSPP	WGT/M		WGT/T	

S4
T24A



LINE MOUNT BODIES



- Aluminum rated to 3000 psi.
- Ductile Iron rated to 5000 psi.

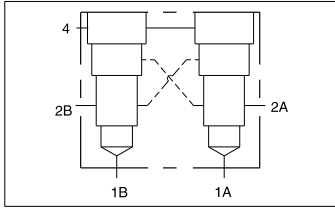

Two cavity cross-piloted body with common port 4 for load control applications.

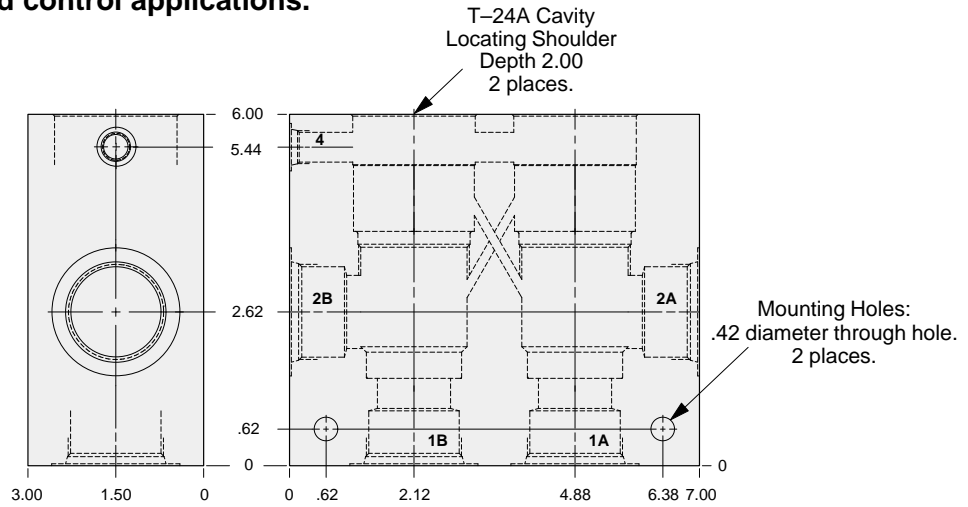

TYPICAL CARTRIDGES USED WITH THIS BODY

- CWIA - *** Page 4.19
 CWIG - *** Page 4.21
 CVIV - *** Page 4.23

Instructions for ordering complete cartridge and body assemblies. Page v

Pressure ratings, material specifications. Page 11.02

Ports 1A, 1B 2A, 2B	Port 4	ALUMINUM		DUCTILE IRON	
		Part Number	List Price	Part Number	List Price
1.00 NPTF	.25 NPTF	XLE		XLE/S	
1.25 NPTF	.25 NPTF	XLF		XLF/S	
SAE-16	SAE-6	XLM		XLM/S	
SAE-20	SAE-6	XLN		XLN/S	
1.00 BSPP	.25 BSPP	XLX		XLX/S	
1.25 BSPP	.25 BSPP	XLY		XLY/S	

S4
T24A

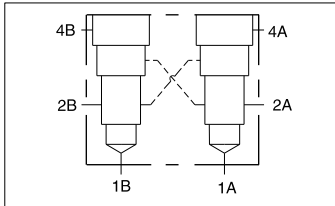

Two cavity cross-piloted body with independent port 4 for load control applications.

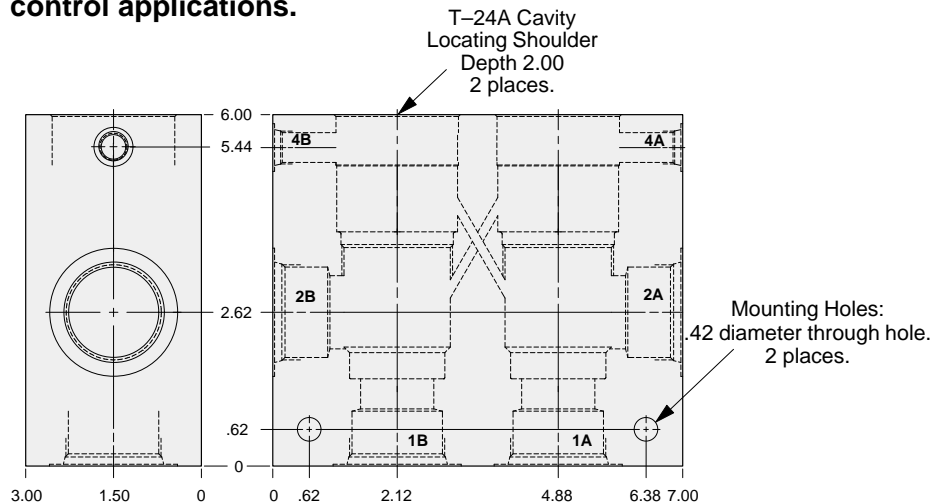

TYPICAL CARTRIDGES USED WITH THIS BODY

- CWIA - *** Page 4.19
 CWIG - *** Page 4.21
 CVIV - *** Page 4.23

Instructions for ordering complete cartridge and body assemblies. Page v

Pressure ratings, material specifications. Page 11.02

Ports 1A, 1B 2A, 2B	Ports 4A & 4B	ALUMINUM		DUCTILE IRON	
		Part Number	List Price	Part Number	List Price
1.00 NPTF	.25 NPTF	XSE		XSE/S	
1.25 NPTF	.25 NPTF	XSF		XSF/S	
SAE-16	SAE-6	XSM		XSM/S	
SAE-20	SAE-6	XSN		XSN/S	
1.00 BSPP	.25 BSPP	XSX		XSX/S	
1.25 BSPP	.25 BSPP	XSY		XSY/S	



LINE MOUNT BODIES

- Aluminum rated to 3000 psi.
- Ductile Iron rated to 5000 psi.

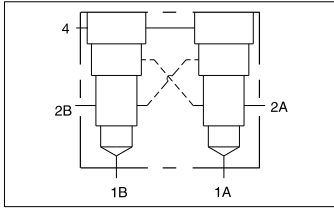

Two cavity cross-piloted 1.50" SAE Code 61 flange port body with common port 4 for load control applications.

1.50" SAE Code 61
4-Bolt Flange Pattern
4 places.

T-24A Cavity
Locating Shoulder
Depth 2.00
2 places.

Mounting Holes:
(opposite side)
Inch: .375-16 UNC-2B
x .62 deep.
Metric: M10 x 1.50-6H
x .62 deep.
2 places.

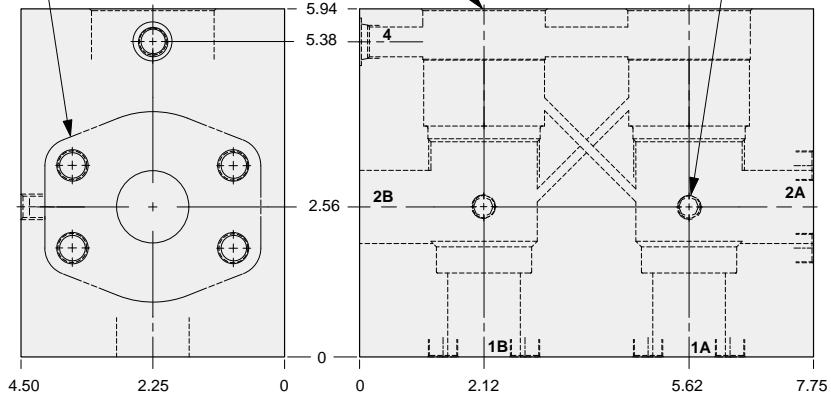

TYPICAL CARTRIDGES USED WITH THIS BODY

- CWIA - *** Page 4.19
CWIG - *** Page 4.21
CVIV - *** Page 4.23

Instructions for ordering complete cartridge and body assemblies. Page v

Pressure ratings, material specifications. Page 11.02

SAE Specifications Page 11.03

Mounting Hole Dimensions	Port 4	ALUMINUM		DUCTILE IRON	
		Part Number	List Price	Part Number	List Price
Inch	SAE-6	XLR		XLR/S	
Metric	.25 BSPP	XLR/M		XLR/T	

S4
T24A

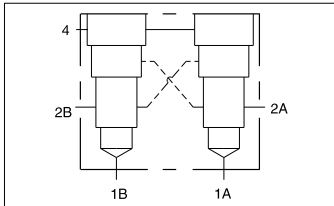

Two cavity cross-piloted 1.50" SAE Code 62 flange port body with common port 4 for load control applications.

1.50" SAE Code 62
4-Bolt Flange Pattern
4 places.

T-24A Cavity
Locating Shoulder
Depth 2.00
2 places.

Mounting Holes:
(opposite side)
Inch: .375-16 UNC-2B
x .62 deep.
Metric: M10 x 1.50-6H
x .62 deep.
2 places.

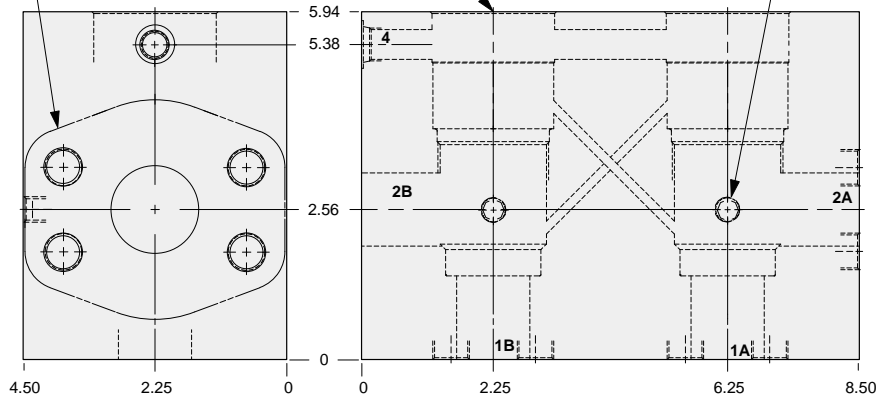

TYPICAL CARTRIDGES USED WITH THIS BODY

- CWIA - *** Page 4.19
CWIG - *** Page 4.21
CVIV - *** Page 4.23

Instructions for ordering complete cartridge and body assemblies. Page v

Pressure ratings, material specifications. Page 11.02

SAE Specifications Page 11.03

Mounting Hole Dimensions	Port 4	ALUMINUM		DUCTILE IRON	
		Part Number	List Price	Part Number	List Price
Inch	SAE-6	XL6		XL6/S	
Metric	.25 BSPP	XL6/M		XL6/T	



LINE MOUNT BODIES



- Aluminum rated to 3000 psi.
- Ductile Iron rated to 5000 psi.

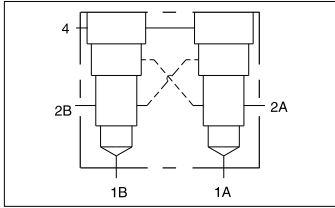

Two cavity cross-piloted 2.00" SAE Code 61 flange port body with common port 4 for load control applications.

TYPICAL CARTRIDGES USED WITH THIS BODY

- CWIA - *** Page 4.19
 CWIG - *** Page 4.21
 CVIV - *** Page 4.23

Instructions for ordering complete cartridge and body assemblies. Page v

Pressure ratings, material specifications. Page 11.02

SAE Specifications Page 11.03

2.00" SAE Code 61
 4-Bolt Flange Pattern
 4 places.

T-24A Cavity
 Locating Shoulder
 Depth 2.00
 2 places.

Mounting Holes:
 (opposite side)
 Inch: .375-16 UNC-2B
 x .62 deep.
 Metric: M10 x 1.50-6H
 x .62 deep.
 2 places.

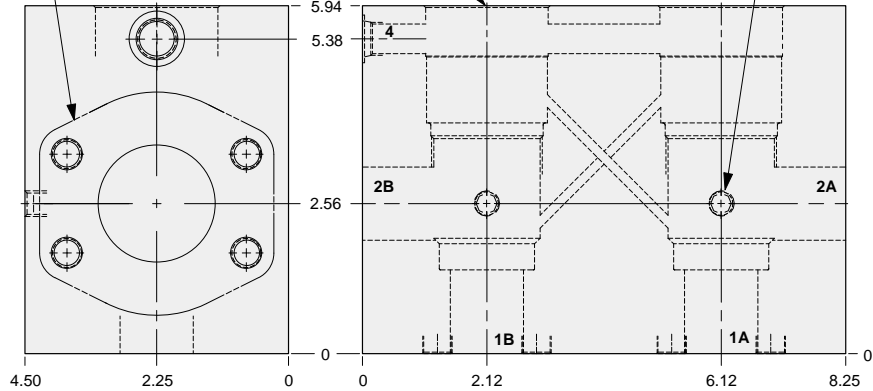

Mounting Hole Dimensions	Port 4	ALUMINUM		DUCTILE IRON	
		Part Number	List Price	Part Number	List Price
Inch	SAE-6	XLS		XLS/S	
Metric	.25 BSPP	XLS/M		XLS/T	

S4
T24A

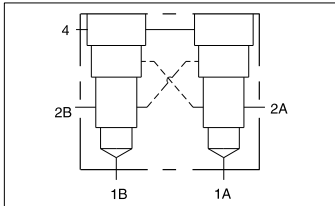

Two cavity cross-piloted 2.00" SAE Code 62 flange port body with common port 4 for load control applications.

TYPICAL CARTRIDGES USED WITH THIS BODY

- CWIA - *** Page 4.19
 CWIG - *** Page 4.21
 CVIV - *** Page 4.23

Instructions for ordering complete cartridge and body assemblies. Page v

Pressure ratings, material specifications. Page 11.02

SAE Specifications Page 11.03

2.00" SAE Code 62
 4-Bolt Flange Pattern
 4 places.

T-24A Cavity
 Locating Shoulder
 Depth 2.00
 2 places.

Mounting Holes:
 (opposite side)
 Inch: .375-16 UNC-2B
 x .62 deep.
 Metric: M10 x 1.50-6H
 x .62 deep.
 2 places.

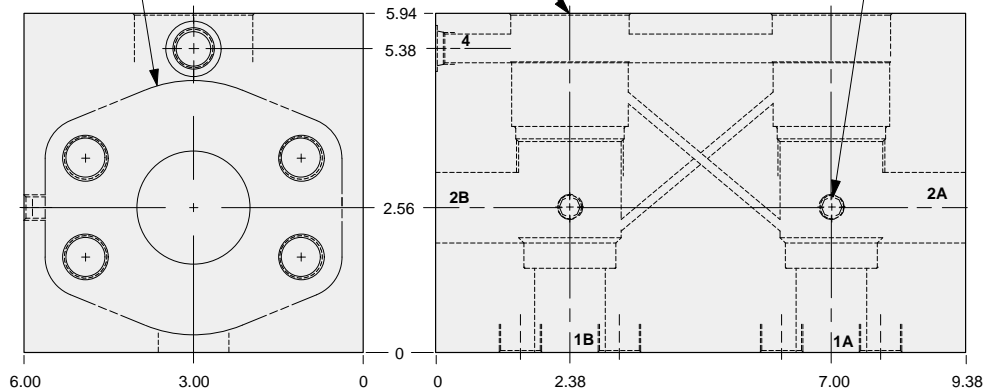

Mounting Hole Dimensions	Port 4	ALUMINUM		DUCTILE IRON	
		Part Number	List Price	Part Number	List Price
Inch	SAE-6	XL8		XL8/S	
Metric	.25 BSPP	XL8/M		XL8/T	



LINE MOUNT BODIES

- Aluminum rated to 3000 psi.
- Ductile Iron rated to 5000 psi.



Two cavity cross-piloted 1.50" SAE Code 61 flange port body with independent port 4 for load control applications.

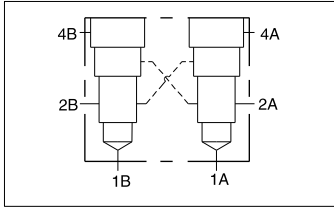

TYPICAL CARTRIDGES USED WITH THIS BODY

- CWIA - *** Page 4.19
 CWIG - *** Page 4.21
 CVIV - *** Page 4.23

Instructions for ordering complete cartridge and body assemblies. Page v

Pressure ratings, material specifications. Page 11.02

SAE Specifications Page 11.03

1.50" SAE Code 61
 4-Bolt Flange Pattern
 4 places.

T-24A Cavity
 Locating Shoulder
 Depth 2.00
 2 places.

Mounting Holes:
 (opposite side)
 Inch: .375-16 UNC-2B
 x .62 deep.
 Metric: M10 x 1.50-6H
 x .62 deep.
 2 places.

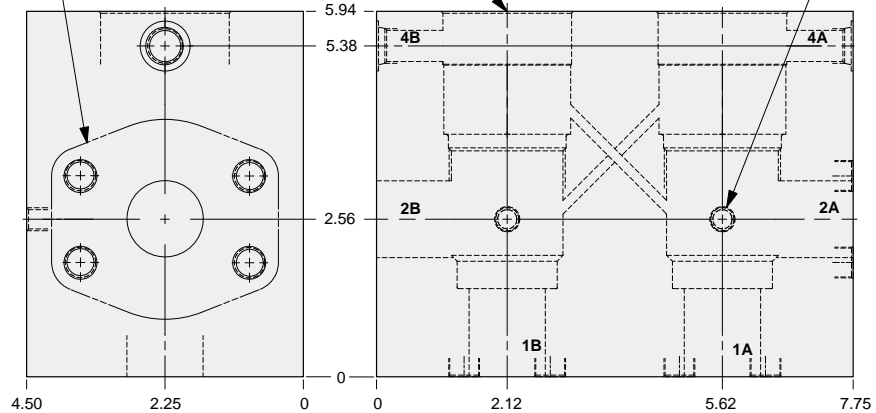

Mounting Hole Dimensions	Ports 4A & 4B	ALUMINUM		DUCTILE IRON	
		Part Number	List Price	Part Number	List Price
Inch	SAE-6	XSR		XSR/S	
Metric	.25 BSPP	XSR/M		XSR/T	

S4
T24A

Two cavity cross-piloted 1.50" SAE Code 62 flange port body with independent port 4 for load control applications.

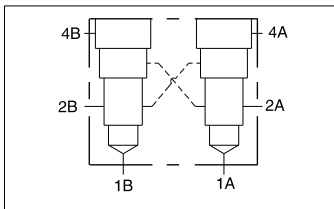

TYPICAL CARTRIDGES USED WITH THIS BODY

- CWIA - *** Page 4.19
 CWIG - *** Page 4.21
 CVIV - *** Page 4.23

Instructions for ordering complete cartridge and body assemblies. Page v

Pressure ratings, material specifications. Page 11.02

SAE Specifications Page 11.03

1.50" SAE Code 62
 4-Bolt Flange Pattern
 4 places.

T-24A Cavity
 Locating Shoulder
 Depth 2.00
 2 places.

Mounting Holes:
 (opposite side)
 Inch: .375-16 UNC-2B
 x .62 deep.
 Metric: M10 x 1.50-6H
 x .62 deep.
 2 places.

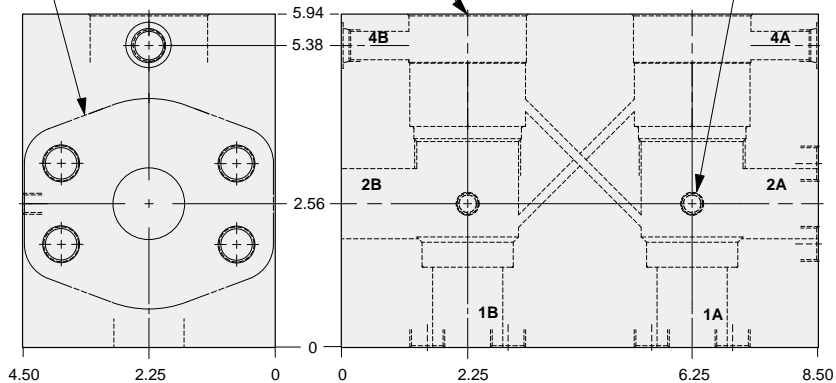

Mounting Hole Dimensions	Ports 4A & 4B	ALUMINUM		DUCTILE IRON	
		Part Number	List Price	Part Number	List Price
Inch	SAE-6	XS6		XS6/S	
Metric	.25 BSPP	XS6/M		XS6/T	



LINE MOUNT BODIES



- Aluminum rated to 3000 psi.
- Ductile Iron rated to 5000 psi.

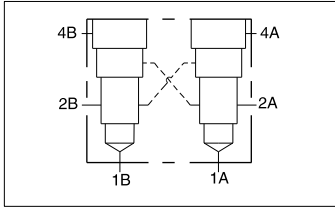

Two cavity cross-piloted 2.00" SAE Code 61 flange port body with independent port 4 for load control applications.

TYPICAL CARTRIDGES USED WITH THIS BODY

- CWIA - *** Page 4.19
 CWIG - *** Page 4.21
 CVIV - *** Page 4.23

Instructions for ordering complete cartridge and body assemblies. Page v

Pressure ratings, material specifications. Page 11.02

SAE Specifications Page 11.03

2.00" SAE Code 61
4-Bolt Flange Pattern
4 places.

T-24A Cavity
Locating Shoulder
Depth 2.00
2 places.

Mounting Holes:
(opposite side)
Inch: .375-16 UNC-2B
x .62 deep.
Metric: M10 x 1.50-6H
x .62 deep.
2 places.

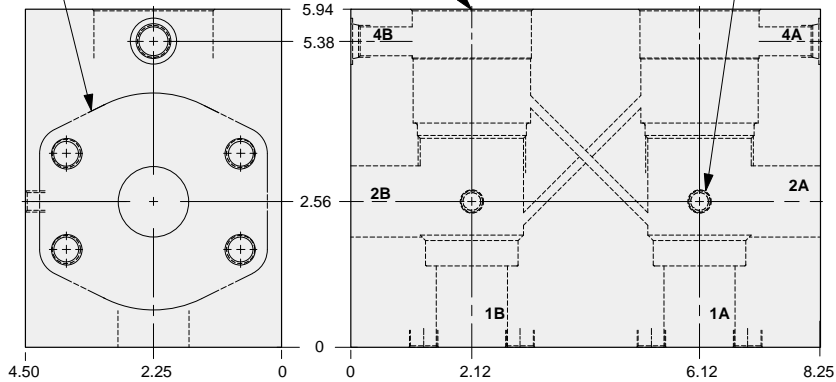

Mounting Hole Dimensions	Port 4	ALUMINUM		DUCTILE IRON	
		Part Number	List Price	Part Number	List Price
Inch	SAE-6	XSS		XSS/S	
Metric	.25 BSPP	XSS/M		XSS/T	

S4
T24A

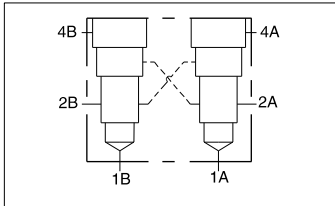

Two cavity cross-piloted 2.00" SAE Code 62 flange port body with independent port 4 for load control applications.

TYPICAL CARTRIDGES USED WITH THIS BODY

- CWIA - *** Page 4.19
 CWIG - *** Page 4.21
 CVIV - *** Page 4.23

Instructions for ordering complete cartridge and body assemblies. Page v

Pressure ratings, material specifications. Page 11.02

SAE Specifications Page 11.03

2.00" SAE Code 62
4-Bolt Flange Pattern
4 places.

T-24A Cavity
Locating Shoulder
Depth 2.00
2 places.

Mounting Holes:
(opposite side)
Inch: .375-16 UNC-2B
x .62 deep.
Metric: M10 x 1.50-6H
x .62 deep.
2 places.

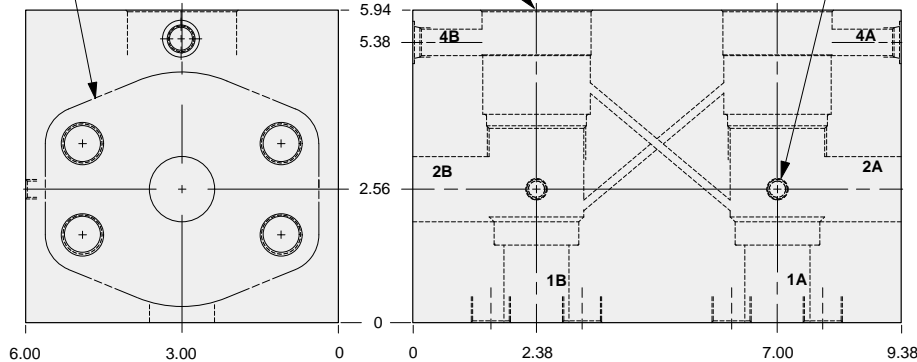

Mounting Hole Dimensions	Port 4	ALUMINUM		DUCTILE IRON	
		Part Number	List Price	Part Number	List Price
Inch	SAE-6	XS8		XS8/S	
Metric	.25 BSPP	XS8/M		XS8/T	



LINE MOUNT BODIES



- Aluminum rated to 3000 psi.
- Ductile Iron rated to 5000 psi.

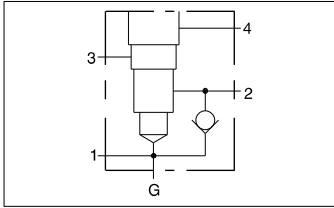

Body with high capacity port 3 reverse free flow check and gage port for reducing/relieving applications.

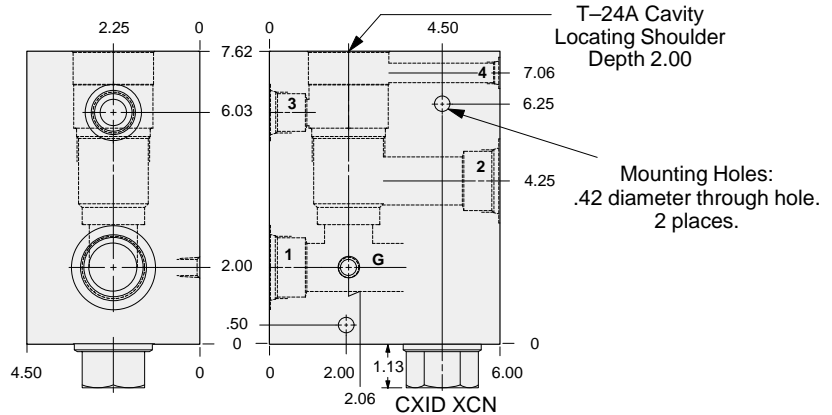

TYPICAL CARTRIDGES USED WITH THIS BODY

PVJA - *** Page 3.15
 PVJB - *** Page 3.17

Cartridge seal type determines check valve seal type.

Instructions for ordering complete cartridge and body assemblies. Page v

Pressure ratings, material specifications. Page 11.02

Ports 1 & 2	Port 3	Port 4	Gage Port	ALUMINUM		DUCTILE IRON	
				Part Number	List Price	Part Number	List Price
.75 NPTF	.75 NPTF	.25 NPTF	.25 NPTF	Q4D		Q4D/S	
1.00 NPTF	.75 NPTF	.25 NPTF	.25 NPTF	Q4E		Q4E/S	
1.25 NPTF	.75 NPTF	.25 NPTF	.25 NPTF	Q4F		Q4F/S	
SAE-12	SAE-12	SAE-6	.25 NPTF	Q4L		Q4L/S	
SAE-16	SAE-12	SAE-6	.25 NPTF	Q4M		Q4M/S	
SAE-20	SAE-12	SAE-6	.25 NPTF	Q4N		Q4N/S	
.75 BSPP	.75 BSPP	.25 BSPP	.25 BSPP	Q4W		Q4W/S	
1.00 BSPP	.75 BSPP	.25 BSPP	.25 BSPP	Q4X		Q4X/S	
1.25 BSPP	.75 BSPP	.25 BSPP	.25 BSPP	Q4Y		Q4Y/S	

S4
T24A



LINE MOUNT BODIES



- Aluminum rated to 3000 psi.
- Ductile Iron rated to 5000 psi.

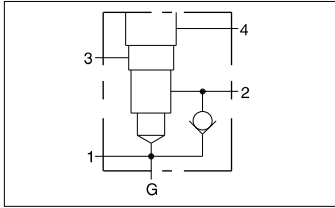

1.50" SAE Code 61 flange port body with high capacity port 3 reverse free flow check and gage port for reducing/relieving applications.

TYPICAL CARTRIDGES USED WITH THIS BODY

- PVJA - *** Page 3.15
 PVJB - *** Page 3.17

Cartridge seal type determines check valve seal type.

Instructions for ordering complete cartridge and body assemblies. Page v

Pressure ratings, material specifications. Page 11.02

SAE Specifications Page 11.03

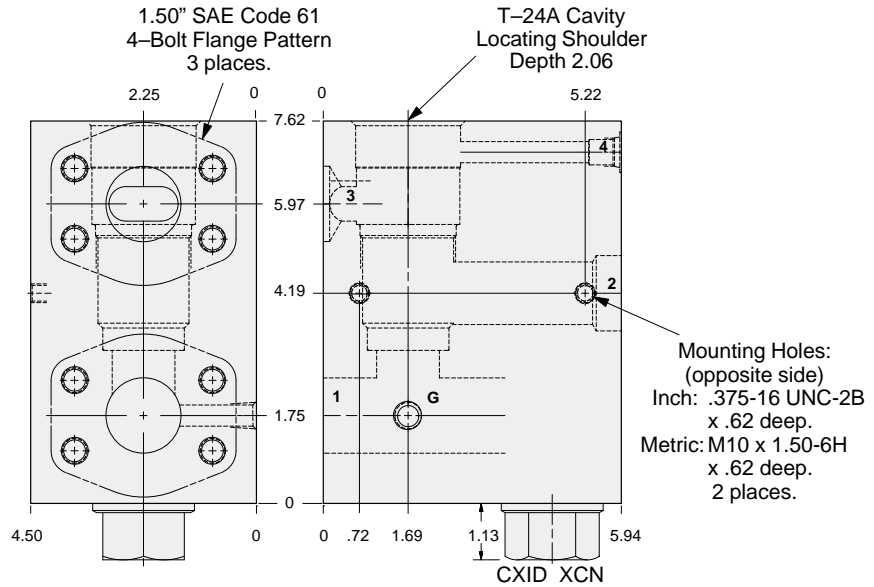

Mounting Hole Dimensions	Port 4	Gage Port	ALUMINUM		DUCTILE IRON	
			Part Number	List Price	Part Number	List Price
Inch	SAE-6	.25 NPTF	Q4R		Q4R/S	
Metric	.25 BSPP	.25 BSPP	Q4R/M		Q4R/T	

S4
T24A

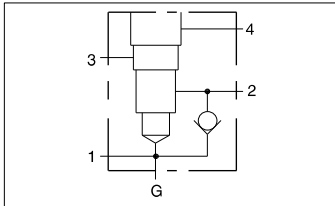

1.50" SAE Code 62 flange port body with high capacity port 3 reverse free flow check and gage port for reducing/relieving applications.

TYPICAL CARTRIDGES USED WITH THIS BODY

- PVJA - *** Page 3.15
 PVJB - *** Page 3.17

Cartridge seal type determines check valve seal type.

Instructions for ordering complete cartridge and body assemblies. Page v

Pressure ratings, material specifications. Page 11.02

SAE Specifications Page 11.03

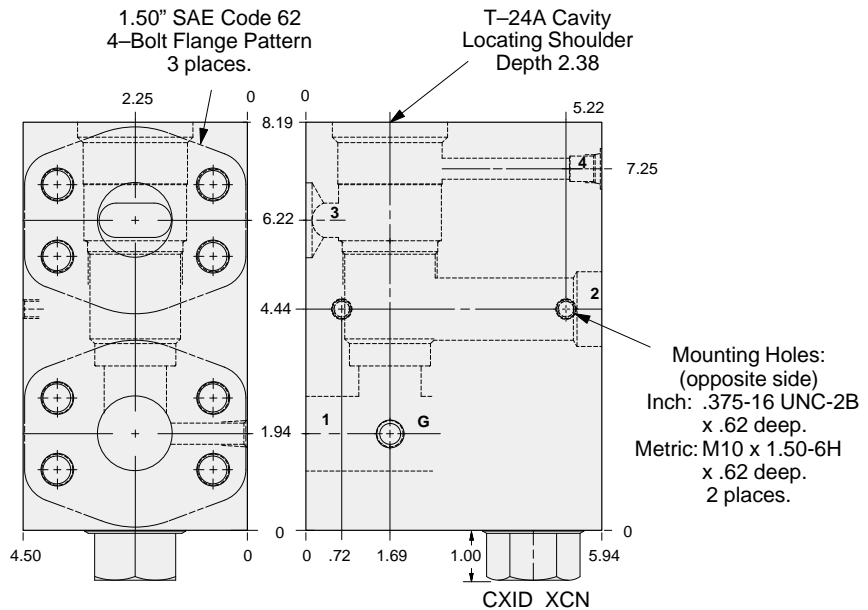

Mounting Hole Dimensions	Port 4	Gage Port	ALUMINUM		DUCTILE IRON	
			Part Number	List Price	Part Number	List Price
Inch	SAE-6	.25 NPTF	Q46		Q46/S	
Metric	.25 BSPP	.25 BSPP	Q46/M		Q46/T	



LINE MOUNT BODIES



- Aluminum rated to 3000 psi.
- Ductile Iron rated to 5000 psi.

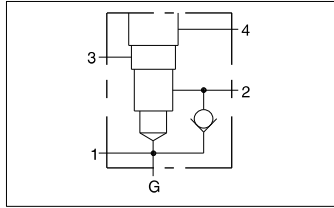

2.00" SAE Code 61 flange port body with high capacity port 3 reverse free flow check and gage port for reducing/relieving applications.

TYPICAL CARTRIDGES USED WITH THIS BODY

PVJA - *** Page 3.15
 PVJB - *** Page 3.17

Cartridge seal type determines check valve seal type.

Instructions for ordering complete cartridge and body assemblies. Page v

Pressure ratings, material specifications. Page 11.02

SAE Specifications Page 11.03

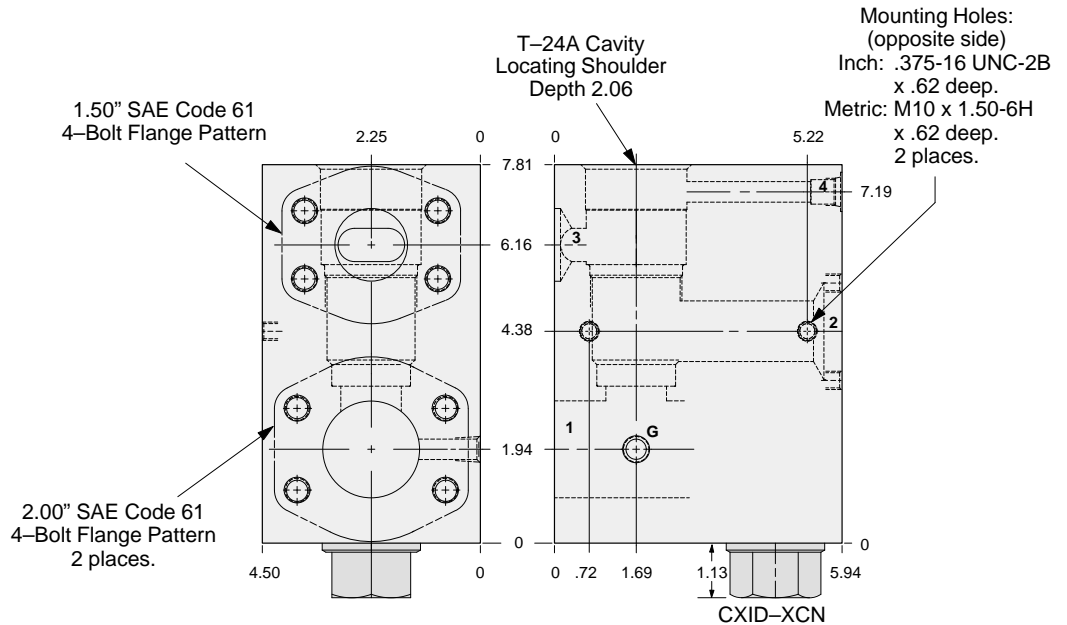

Mounting Hole Dimensions	Port 4	Gage Port	ALUMINUM		DUCTILE IRON	
			Part Number	List Price	Part Number	List Price
Inch	SAE-6	.25 NPTF	Q4S		Q4S/S	
Metric	.25 BSPP	.25 BSPP	Q4S/M		Q4S/T	

S4
T24A

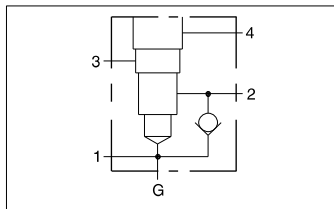

2.00" SAE Code 62 flange port body with high capacity port 3 reverse free flow check and gage port for reducing/relieving applications.

TYPICAL CARTRIDGES USED WITH THIS BODY

PVJA - *** Page 3.15
 PVJB - *** Page 3.17

Cartridge seal type determines check valve seal type.

Instructions for ordering complete cartridge and body assemblies. Page v

Pressure ratings, material specifications. Page 11.02

SAE Specifications Page 11.03

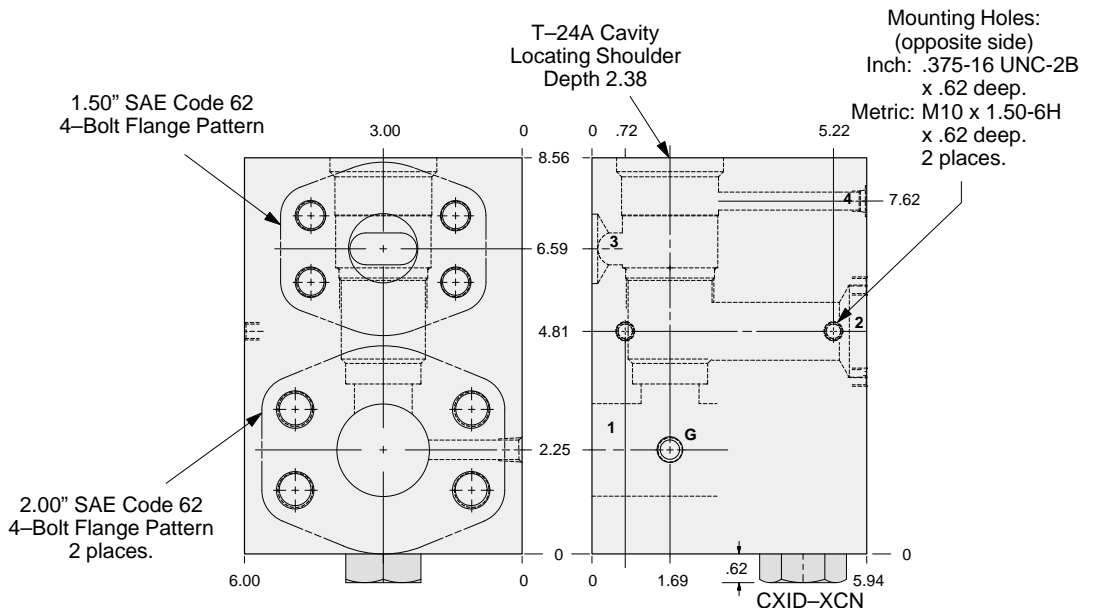

Mounting Hole Dimensions	Port 4	Gage Port	ALUMINUM		DUCTILE IRON	
			Part Number	List Price	Part Number	List Price
Inch	SAE-6	.25 NPTF	Q48		Q48/S	
Metric	.25 BSPP	.25 BSPP	Q48/M		Q48/T	



LINE MOUNT BODIES



- Aluminum rated to 3000 psi.
- Ductile Iron rated to 5000 psi.

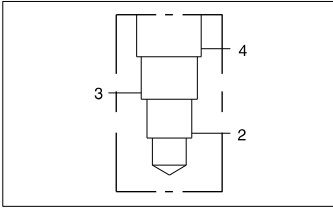

Body for flow divider/combiner applications

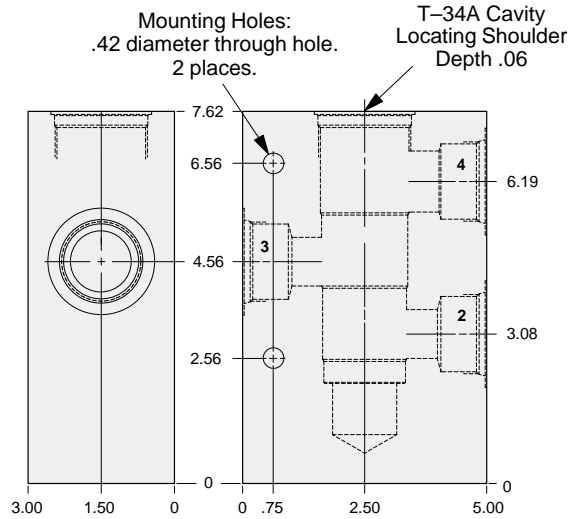

TYPICAL CARTRIDGES USED WITH THIS BODY

- FSFD - *** Page 7.09
- FSFA - *** Page 7.11
- FSFS - *** Page 7.13
- FSFH - *** Page 7.15
- DSIH - *** Page 10.07

Instructions for ordering complete cartridge and body assemblies. Page v

Pressure ratings, material specifications. Page 11.02

Ports 2, 3, & 4	ALUMINUM		DUCTILE IRON	
	Part Number	List Price	Part Number	List Price
1.00 NPTF	QME		QME/S	
1.25 NPTF	QMF		QMF/S	
SAE-16	QMM		QMM/S	
SAE-20	QMN		QMN/S	
1.00 BSPP	QMX		QMX/S	
1.25 BSPP	QMY		QMY/S	

S4
T34A

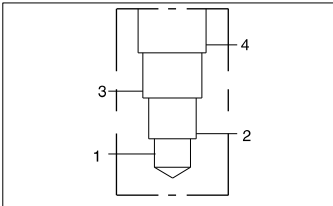

Four port body.

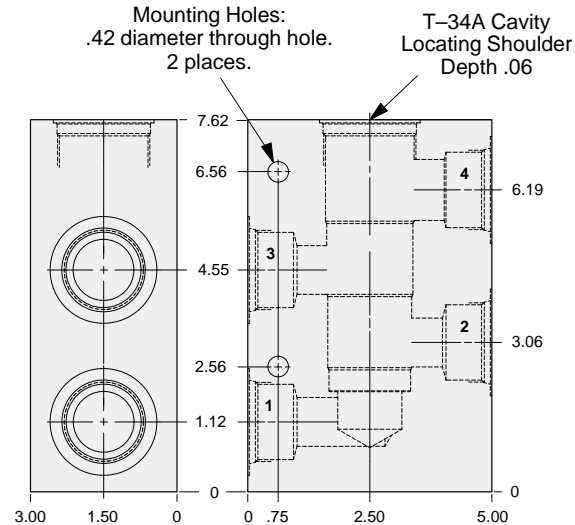

Instructions for ordering complete cartridge and body assemblies. Page v

Pressure ratings, material specifications. Page 11.02

Ports 2, 3, & 4	ALUMINUM		DUCTILE IRON	
	Part Number	List Price	Part Number	List Price
1.00 NPTF	QNE		QNE/S	
1.25 NPTF	QNF		QNF/S	
SAE-16	QNM		QNM/S	
SAE-20	QNN		QNN/S	
1.00 BSPP	QNX		QNX/S	
1.25 BSPP	QNY		QNY/S	



LINE MOUNT BODIES



- Aluminum rated to 3000 psi.
- Ductile Iron rated to 5000 psi.

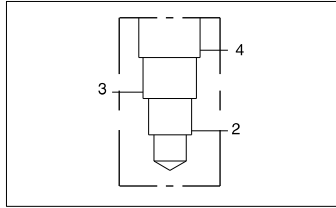

1.00" SAE Code 61 flange port body for flow divider/combiner applications.

1.00" SAE Code 61
4-Bolt Flange Pattern
3 places.

T-34A Cavity
Locating Shoulder
Depth .06

Mounting Holes:
Inch: .375-16 UNC-2B
x .62 deep.
Metric: M10 x 1.50-6H
x .62 deep.
2 places.

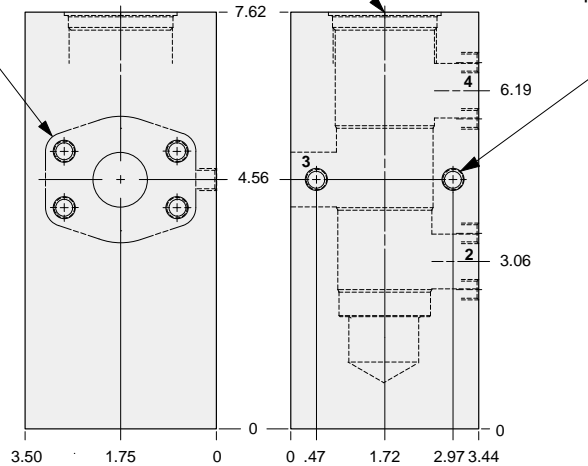

TYPICAL CARTRIDGES USED WITH THIS BODY

FSFD - ***	Page 7.09
FSFA - ***	Page 7.11
FSFS - ***	Page 7.13
FSFH - ***	Page 7.15
DSIH - ***	Page 10.07

Instructions for ordering complete cartridge and body assemblies. Page v

Pressure ratings, material specifications. Page 11.02

SAE Specifications Page 11.03

Mounting Hole Dimensions	ALUMINUM		DUCTILE IRON	
	Part Number	List Price	Part Number	List Price
Inch	QMP		QMP/S	
Metric	QMP/M		QMP/T	

S4
T34A

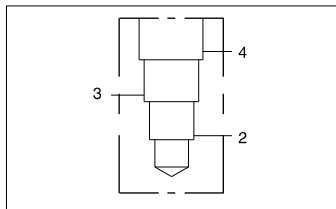

1.00" SAE Code 62 flange port body for flow divider/combiner applications.

1.00" SAE Code 62
4-Bolt Flange Pattern
3 places.

T-34A Cavity
Locating Shoulder
Depth .06

Mounting Holes:
Inch: .375-16 UNC-2B
x .62 deep.
Metric: M10 x 1.50-6H
x .62 deep.
2 places.

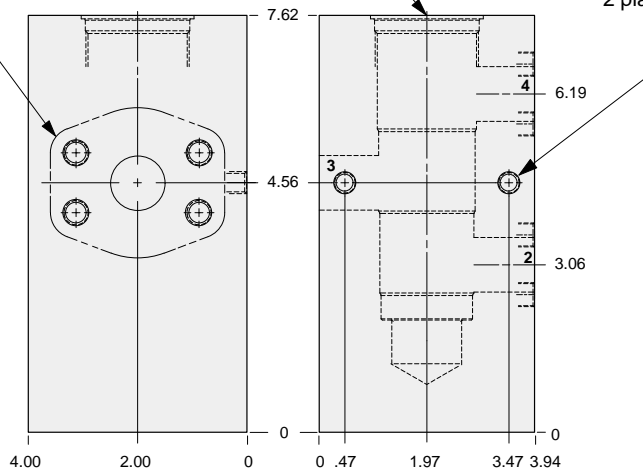

TYPICAL CARTRIDGES USED WITH THIS BODY

FSFD - ***	Page 7.09
FSFA - ***	Page 7.11
FSFS - ***	Page 7.13
FSFH - ***	Page 7.15
DSIH - ***	Page 10.07

Instructions for ordering complete cartridge and body assemblies. Page v

Pressure ratings, material specifications. Page 11.02

SAE Specifications Page 11.03

Mounting Hole Dimensions	ALUMINUM		DUCTILE IRON	
	Part Number	List Price	Part Number	List Price
Inch	QM4		QM4/S	
Metric	QM4/M		QM4/T	



LINE MOUNT BODIES



- Aluminum rated to 3000 psi.
- Ductile Iron rated to 5000 psi.

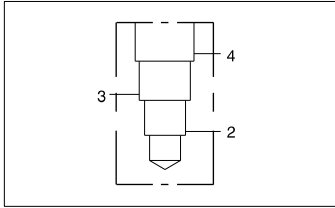

1.25" SAE Code 61 flange port body for flow divider/combiner applications.

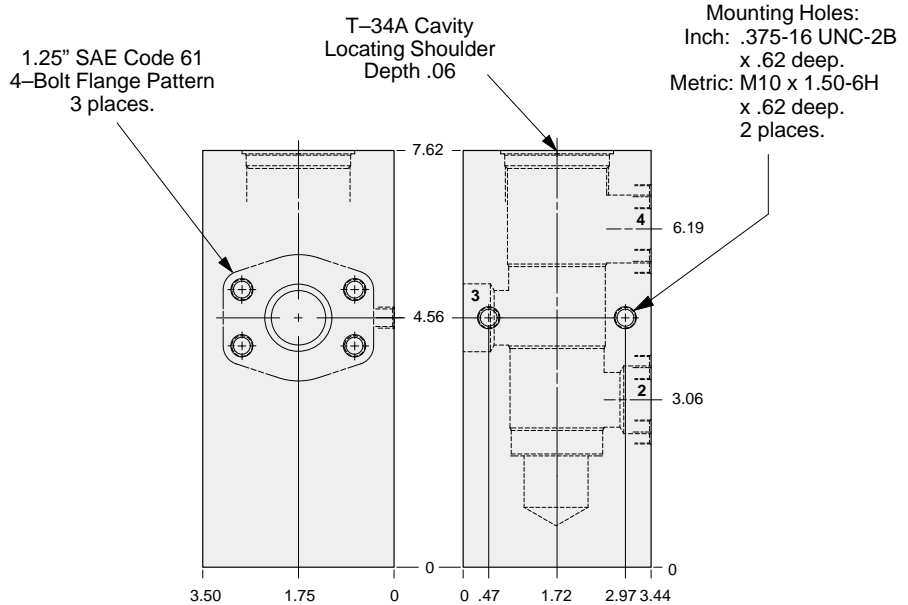

TYPICAL CARTRIDGES USED WITH THIS BODY

- FSFD - *** Page 7.09
- FSFA - *** Page 7.11
- FSFS - *** Page 7.13
- FSFH - *** Page 7.15
- DSIH - *** Page 10.07

Instructions for ordering complete cartridge and body assemblies. Page v

Pressure ratings, material specifications. Page 11.02

SAE Specifications Page 11.03

Mounting Hole Dimensions	ALUMINUM		DUCTILE IRON	
	Part Number	List Price	Part Number	List Price
Inch	QM _Q		QM _{Q/S}	
Metric	QM _{Q/M}		QM _{Q/T}	

S4
T34A

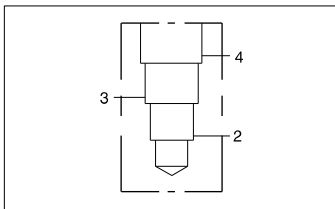

1.25" SAE Code 62 flange port body for flow divider/combiner applications.

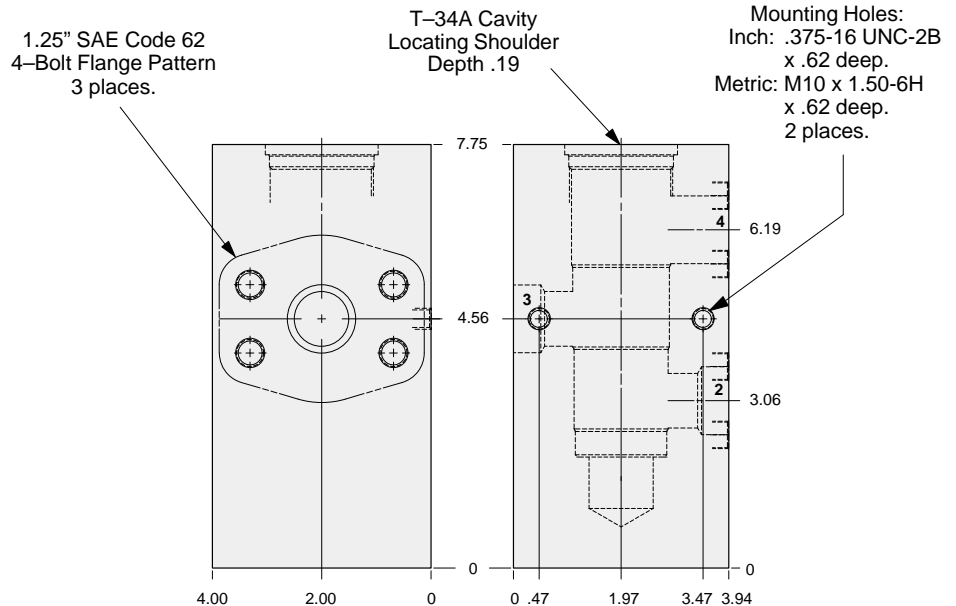

TYPICAL CARTRIDGES USED WITH THIS BODY

- FSFD - *** Page 7.09
- FSFA - *** Page 7.11
- FSFS - *** Page 7.13
- FSFH - *** Page 7.15
- DSIH - *** Page 10.07

Instructions for ordering complete cartridge and body assemblies. Page v

Pressure ratings, material specifications. Page 11.02

SAE Specifications Page 11.03

Mounting Hole Dimensions	ALUMINUM		DUCTILE IRON	
	Part Number	List Price	Part Number	List Price
Inch	QM ₅		QM _{5/S}	
Metric	QM _{5/M}		QM _{5/T}	



LINE MOUNT BODIES



- Aluminum rated to 3000 psi.
- Ductile Iron rated to 5000 psi.

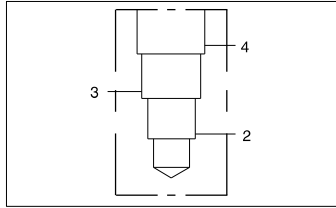

1.50" SAE Code 61 flange port body for flow divider/combiner applications.

TYPICAL CARTRIDGES USED WITH THIS BODY

- FSFD - *** Page 7.09
- FSFA - *** Page 7.11
- FSFS - *** Page 7.13
- FSFH - *** Page 7.15
- DSIH - *** Page 10.07

Instructions for ordering complete cartridge and body assemblies. Page v

Pressure ratings, material specifications. Page 11.02

SAE Specifications Page 11.03

1.50" SAE Code 61 4-Bolt Flange Pattern

T-34A Cavity Locating Shoulder Depth .06

Mounting Holes:
Inch: .375-16 UNC-2B x .62 deep.
Metric: M10 x 1.50-6H x .62 deep.
2 places.

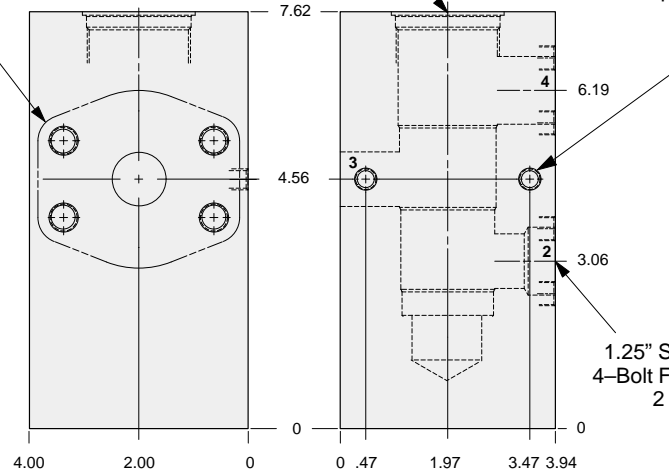

Mounting Hole Dimensions	ALUMINUM		DUCTILE IRON	
	Part Number	List Price	Part Number	List Price
Inch	QMR		QMR/S	
Metric	QMR/M		QMR/T	

S4 T34A

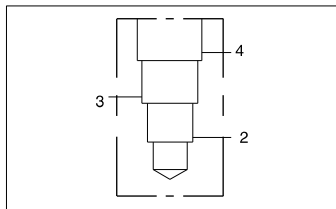

1.50" SAE Code 62 flange port body for flow divider/combiner applications.

TYPICAL CARTRIDGES USED WITH THIS BODY

- FSFD - *** Page 7.09
- FSFA - *** Page 7.11
- FSFS - *** Page 7.13
- FSFH - *** Page 7.15
- DSIH - *** Page 10.07

Instructions for ordering complete cartridge and body assemblies. Page v

Pressure ratings, material specifications. Page 11.02

SAE Specifications Page 11.03

1.50" SAE Code 62 4-Bolt Flange Pattern

T-34A Cavity Locating Shoulder Depth .19

Mounting Holes:
Inch: .375-16 UNC-2B x .62 deep.
Metric: M10 x 1.50-6H x .62 deep.
2 places.

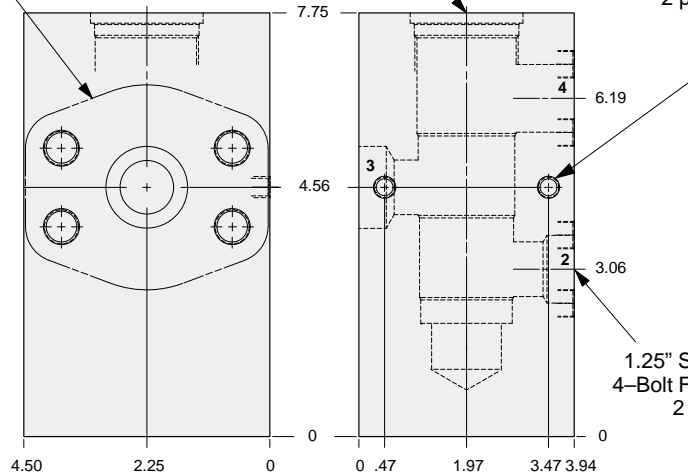

Mounting Hole Dimensions	ALUMINUM		DUCTILE IRON	
	Part Number	List Price	Part Number	List Price
Inch	QM6		QM6/S	
Metric	QM6/M		QM6/T	



VALVE ASSEMBLY PACKAGES

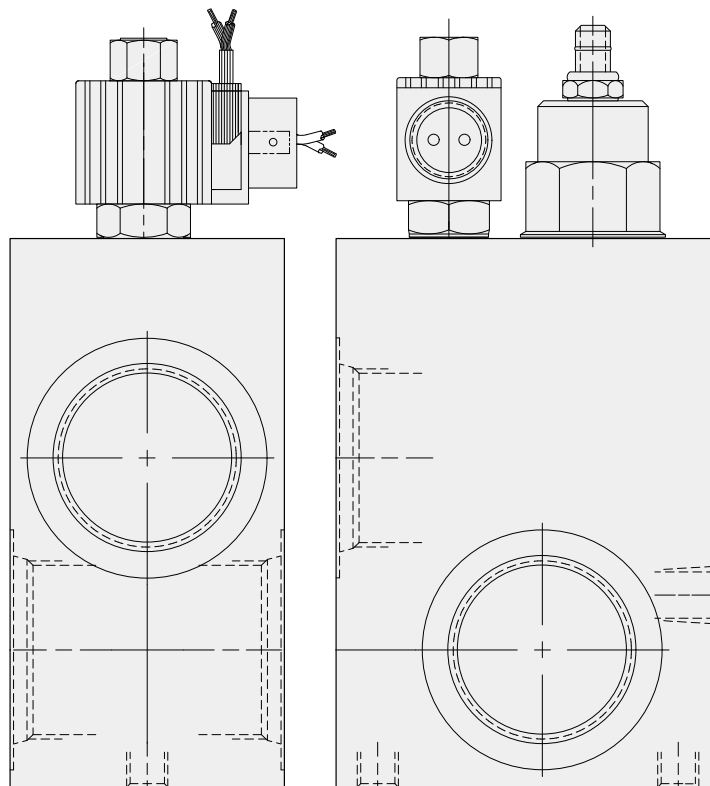



VALVE ASSEMBLY PACKAGE LOCATOR



VALVE PACKAGE	FUNCTION	ASSEMBLY		CARTRIDGE INCLUDED	
		MODEL CODE	PAGE	MODEL CODE	PAGE
Solenoid Operated Ventable Relief Assembly <i>Normally open</i>		YRCG-LAN-**	13.02	RVCA	1.18
		YREG-LAN-**	13.04	RVEA	1.18
		YRFG-LAN-**	13.06, 13.07	RVGA	1.19
		YRHG-LAN-**	13.10, 13.11	RVIA	1.19
		YROG-LAN-**	13.03	RVCA	1.18
		YRPG-LAN-**	13.05	RVEA	1.18
		YRQG-LAN-**	13.08, 13.09	RVGA	1.19
		YRRG-LAN-**	13.12, 13.13	RVIA	1.19
Solenoid Operated Ventable Relief Assembly <i>Normally Closed</i>		YRCH-LAN-**	13.02	RVCA	1.18
		YREH-LAN-**	13.04	RVEA	1.18
		YRFH-LAN-**	13.06, 13.07	RVGA	1.19
		YRHH-LAN-**	13.10, 13.11	RVIA	1.19
		YROH-LAN-**	13.03	RVCA	1.18
		YRPH-LAN-**	13.05	RVEA	1.18
		YRQH-LAN-**	13.08, 13.09	RVGA	1.19
		YRRH-LAN-**	13.12, 13.13	RVIA	1.19
Solenoid and Pilot Relief Assembly <i>Normally Open</i>		YRAG-LAN-**	13.14	RBAC	1.16
Solenoid and Pilot Relief Assembly <i>Normally Closed</i>		YRAH-LAN-**	13.14	RBAC	1.16
Cross-Port Relief Assembly with Shuttle and Solenoid Operated Vent <i>Normally Open</i>		YVCG-LAN-**	13.15	RVCA	1.18
				CSAB	10.08
		YVEG-LAN-**	13.16	RVEA	1.18
				CSAB	10.08
				RVGA	1.19
YVFG-LAN-**	13.17, 13.18, 13.19	RVGA	1.19		
		CSAB	10.08		



VALVE ASSEMBLY PACKAGE LOCATOR



VALVE PACKAGE	FUNCTION	ASSEMBLY		CARTRIDGE INCLUDED		
		MODEL CODE	PAGE	MODEL CODE	PAGE	
Cross-Port Relief Assembly with Shuttle and Solenoid Operated Vent <i>Normally Closed</i>		YVCH-LAN-**	13.15	RVCA	1.18	
					CSAB	10.08
		YVEH-LAN-**	13.16	RVEA	1.18	
				CSAB	10.08	
		YVFH-LAN-**	13.17, 13.18, 13.19	RVGA	1.19	
				CSAB	10.08	
Hydrostatic Transmission Assembly		XRDB-LCN-A*	13.20, 13.21	DSCH	10.06	
				RDDA	1.10	
				RPEC	1.06	
		XRFB-LCN-A*	13.22, 13.23	DSEH	10.06	
				RDFA	1.10	
				RPEC	1.06	
		XRHB-LCN-A*	13.24, 13.25	DSGH	10.07	
				RDHA	1.11	
				RPGC	1.06	
		XRJB-LCN-A*	13.26, 13.27	DSIH	10.07	
				RDJA	1.11	
				RPIC	1.07	
Hot Oil Shuttle and Relief Assembly		XRDC-LNN-A*	13.28, 13.29	DSCH	10.06	
				RPEC	1.06	
		XRFC-LNN-A*	13.30, 13.31	DSEH	10.06	
				RPEC	1.06	
		XRHC-LNN-A*	13.32, 13.33	DSGH	10.07	
				RPGC	1.06	
		XRJC-LNN-A*	13.35, 13.36, 13.37	DSIH	10.07	
				RPIC	1.07	
Flow Divider/Combiner Tractive Drive Assembly		YGCB-XAN-**	13.38	FSCH	7.14	
		YGDB-XAN-**	13.39	FSDH	7.14	
		YGEB-XAN-**	13.40	FSEH	7.15	
		YGFB-XAN-**	13.41	FSFH	7.15	



VALVE ASSEMBLY PACKAGE LOCATOR



VALVE PACKAGE	FUNCTION	ASSEMBLY		CARTRIDGE INCLUDED	
		MODEL CODE	PAGE	MODEL CODE	PAGE
Regeneration Assembly Pressure Sensitive		YDCC-LHN-A*	13.43	CODA	10.12
				CBCA	4.10
		YDEC-LHN-A*	13.44	COFA	10.12
				CBEA	4.10
		YDGC-LHN-A*	13.45	COHA	10.13
				CBGA	4.11
		YDHC-LHN-A*	13.47	COHA (2)	10.13
				CBGA (2)	4.11
		YDJC-LHN-A*	13.48	COJA	10.13
				CBIA	4.11
		YDJC-LHN-A*	13.49	COJA (2)	10.13
				CBIA (2)	4.11
Regeneration Assembly Pressure Sensitive with Load Locking Pilot Operated Check		YDCD-LHN-A*	13.43	CODA	10.12
				CBCA	4.10
				CKEB	4.16
		YDED-LHN-A*	13.44	COFA	10.12
				CBEA	4.10
				CKEB	4.16
		YDGD-LHN-A*	13.46	COHA	10.13
				CBGA	4.11
				CKGB	4.17
Accumulator Dump Assembly		YCFE-XAN-A*	13.50	CXFA	5.08
				COFA	10.12
		YCHE-XAN-A*	13.51	CXHA	5.09
				CODA	10.12
Pump Circuit Manifold for Multiple Pump Circuits		YFRC-LAN-A*	13.52	CXFA	5.08
				NQEB	10.16
				RPGC	1.06
		YFRE-LAN-A*	13.52	CXHA	5.09
				NQEB	10.16
				RPIC	1.07

13



VALVE ASSEMBLY PACKAGE LOCATOR

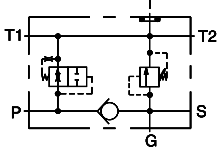
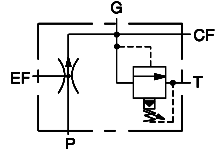

VALVE PACKAGE	FUNCTION	ASSEMBLY		CARTRIDGE INCLUDED	
		MODEL CODE	PAGE	MODEL CODE	PAGE
Pump Circuit Mainfold for Single Pump Circuits 		YFRD-LAN-A*	13.53	CXFA	5.08
				NQEB	10.16
				RPGC	1.06
		YFRF-LAN-A*	13.53	CXHA	5.09
				NQEB	10.16
				RPIC	1.07
Priority Flow Control with Controlled Flow Port Relief Valve 		YRDR-LAN-**	13.54	FRCA	6.02
				RPEC	1.06
		YREM-LAN-**	13.54	FRDA	6.02
				RPEC	1.06
		YRFF-LAN-**	13.55	FREA	6.03
				RPEC	1.06
		YRHF-LAN-**	13.56	FRFA	6.03
				RPGC	1.06

NOTES

This section of the SUN's catalog includes valve assembly packages designed for specific hydraulic functions. SUN's valve assemblies typically contain two or more different cartridges and provide several hydraulic functions.

Section	Page
<i>Valve Assemblies:</i>	
Solenoid Operated Ventable Relief	13.02–13.13
Solenoid and Relief Pilot Flow	13.14
Cross-Port Relief with Shuttle and Solenoid Operated Vent	13.15–13.19
Hydrostatic Transmission	13.20–13.27
Hot Oil Shuttle and Relief	13.28–13.37
Flow Divider/Combiner Tractive Drive	13.38–13.41
Regeneration	13.42–13.49
Accumulator Dump Circuits	13.50–13.51
Pump Circuits Control	13.52–13.53
Pressure-Compensated Priority Flow Control	13.54–13.56

Ordering

Use a nine-digit part number when ordering valve assemblies. You must select a number of different options to complete a part number.

We have supplied pricing in Sun's most recent price list for a basic part number that gives you a configuration that provides the required performance characteristics for the majority of applications. If you desire to change a cartridge option (controls or adjustment range) in a valve assembly, we have provided you with the cartridge page number for those cartridges where we allow option substitution.

Designated cartridge option pricing must be added to (or subtracted from) the basic pricing to obtain the complete pricing of the valve assembly. Like all other mounting configurations in this catalog, all valve assemblies are available in both aluminum and ductile iron with a variety of porting options. Consult Sun's most recent price list for basic prices and option prices.

Electrical Connector Options for Solenoid Operated Assemblies

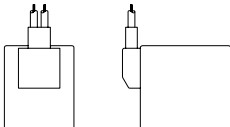
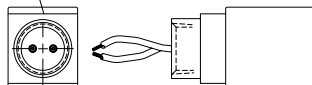
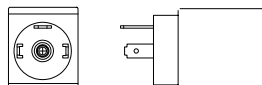
WIRE LEADS	CONDUIT	ISO/DIN
 <p>18 Gage 24" Long</p>	<p>1/2" NPTF</p>  <p>18 Gage 24" Long</p>	 <p>DIN 43650 Plug Face</p>
<p>J–12 V DC–24" Leads +</p> <p>K–24 V DC–24" Leads +</p>	<p>N–115 V 50/60hz–Conduit +</p> <p>O–230 V 50/60hz–Conduit +</p>	<p>S–12 V DC ISO/DIN +</p> <p>T–24 V DC ISO/DIN +</p> <p>V–230 V 50/60hz ISO/DIN +</p> <p>W–120 V 50/60Hz ISO/DIN +</p>



**SOLENOID OPERATED VENTABLE RELIEF ASSEMBLY
INLINE BODY WITH GAGE PORT**



YRC*-LAN-**

Consult the Sun Web Site for
[Conversion List \(Old-to-New Model Code Cross Reference\)](#)



**SOLENOID OPERATED VENTABLE RELIEF ASSEMBLY
.75" SAE CODE 61 SANDWICH MOUNT BODY**



YRO*-LAN-**

Consult the Sun Web Site for
[Conversion List \(Old-to-New Model Code Cross Reference\)](#)



**SOLENOID OPERATED VENTABLE RELIEF ASSEMBLY
INLINE BODY WITH GAGE PORT**



YRE*-LAN-**

Consult the Sun Web Site for
[Conversion List \(Old-to-New Model Code Cross Reference\)](#)



**SOLENOID OPERATED VENTABLE RELIEF ASSEMBLY
1.00"SAE CODE 61 SANDWICH MOUNT BODY WITH GAGE PORT**



YRP*-LAN-**

Consult the Sun Web Site for
[Conversion List \(Old-to-New Model Code Cross Reference\)](#)



**SOLENOID OPERATED VENTABLE RELIEF ASSEMBLY
INLINE BODY WITH GAGE PORT**



YRF*-LAN-**

Consult the Sun Web Site for
[Conversion List \(Old-to-New Model Code Cross Reference\)](#)



**SOLENOID OPERATED VENTABLE RELIEF ASSEMBLY
SAE CODE 61 FLANGE PORT BODY**



YRF*-LAN-**

Consult the Sun Web Site for
[Conversion List \(Old-to-New Model Code Cross Reference\)](#)



YRQ*-LAN-**

Consult the Sun Web Site for
[Conversion List \(Old-to-New Model Code Cross Reference\)](#)



**SOLENOID OPERATED VENTABLE RELIEF ASSEMBLY
1.25" SAE CODE 61 SANDWICH MOUNT BODY WITH GAGE PORT**



YRQ*-LAN-**

Consult the Sun Web Site for
[Conversion List \(Old-to-New Model Code Cross Reference\)](#)



**SOLENOID OPERATED VENTABLE RELIEF ASSEMBLY
1.50" SAE CODE 61 FLANGE PORT BODY WITH GAGE PORT**



YRH*-LAN-**

Consult the Sun Web Site for
[Conversion List \(Old-to-New Model Code Cross Reference\)](#)



**SOLENOID OPERATED VENTABLE RELIEF ASSEMBLY
2.00" SAE CODE 61 FLANGE PORT BODY WITH GAGE PORT**



YRH*-LAN-**

Consult the Sun Web Site for
[Conversion List \(Old-to-New Model Code Cross Reference\)](#)



YRR*-LAN-**

Consult the Sun Web Site for
[Conversion List \(Old-to-New Model Code Cross Reference\)](#)



**SOLENOID OPERATED VENTABLE RELIEF ASSEMBLY
1.50" SAE CODE 61 SANDWICH MOUNT BODY WITH GAGE PORT**



YRR*-LAN-**

Consult the Sun Web Site for
[Conversion List \(Old-to-New Model Code Cross Reference\)](#)



**SOLENOID AND RELIEF PILOT CONTROL ASSEMBLY
FOR PILOT FLOW USE ONLY (60 in³/min maximum flow)**



YRA*-LAN-**

Consult the Sun Web Site for
[Conversion List \(Old-to-New Model Code Cross Reference\)](#)



CROSS-PORT RELIEF ASSEMBLY WITH SHUTTLE AND SOLENOID OPERATED VENT



- Maximum operating pressure 3000 psi.
- Power requirement: 12 watts.

YVEG: Normally Open

YVEH: Normally Closed

ALUMINUM		DUCTILE IRON		Ports 1 & 2	Port V	Ports G1 & G2	ALUMINUM		DUCTILE IRON	
Port Code	List Price*	Port Code	List Price*				Port Code	List Price*	Port Code	List Price*
B		B/S		.375 NPTF	.25 NPTF	.25 NPTF	B		B/S	
C		C/S		.50 NPTF	.25 NPTF	.25 NPTF	C		C/S	
D		D/S		.75 NPTF	.25 NPTF	.25 NPTF	D		D/S	
E		E/S		1.00 NPTF	.25 NPTF	.25 NPTF	E		E/S	
I		I/S		SAE-6	SAE-6	.25 NPTF	I		I/S	
J		J/S		SAE-8	SAE-6	.25 NPTF	J		J/S	
K		K/S		SAE-10	SAE-6	.25 NPTF	K		K/S	
L		L/S		SAE-12	SAE-6	.25 NPTF	L		L/S	
M		M/S		SAE-16	SAE-6	.25 NPTF	M		M/S	
U		U/S		.375 BSPP	.25 BSPP	.25 BSPP	U		U/S	
V		V/S		.50 BSPP	.25 BSPP	.25 BSPP	V		V/S	
W		W/S		.75 BSPP	.25 BSPP	.25 BSPP	W		W/S	
X		X/S		1.00 BSPP	.25 BSPP	.25 BSPP	X		X/S	

*For part number and price for body only contact your local SUN distributor.

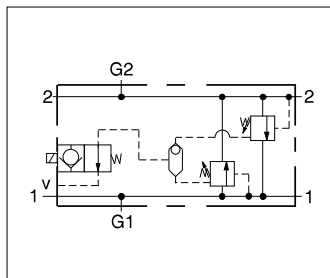

Normally Open
Solenoid Valve

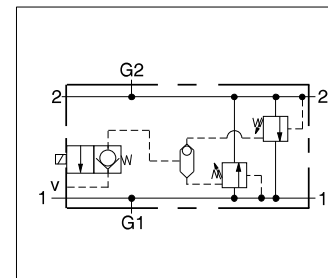

Normally Closed
Solenoid Valve

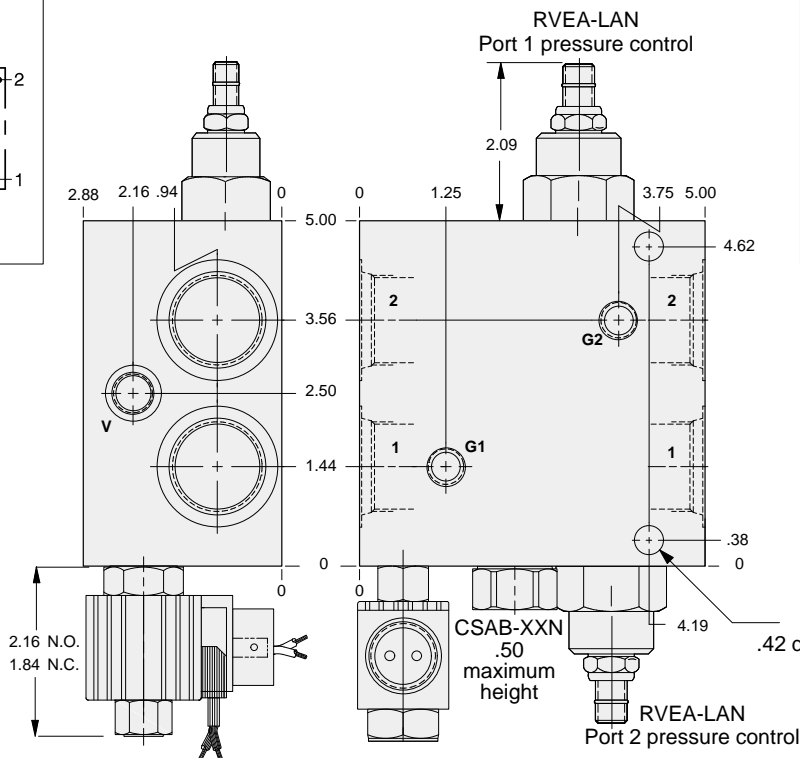

OPTIONS

YVE * - LAN **

G Normally Open

H Normally Closed

CARTRIDGE

RVEA Pg 1.18

For Viton Seals Change LAN to LAV.

Customer Specified Setting Stamped on Hex

SOLENOID COILS

J 12 volt DC, 24" leads

K 24 volt DC, 24" leads

N 115 volt, 50/60 Hz, conduit

O 230 volt, 50/60 Hz, conduit

S 12 volt DC, ISO/DIN

V 24 volt DC, ISO/DIN

V 230 volt, 50/60 Hz, ISO/DIN

W 120 volt, 50/60 Hz, ISO/DIN

PORTS

See Chart above



CROSS-PORT RELIEF ASSEMBLY WITH SHUTTLE AND SOLENOID OPERATED VENT



- Maximum operating pressure 3000 psi.
- Power requirement: 12 watts.

YVFG: Normally Open

YVFH: Normally Closed

ALUMINUM		DUCTILE IRON		Ports 1 & 2	Port V	Ports G1 & G2	ALUMINUM		DUCTILE IRON	
Port Code	List Price*	Port Code	List Price*				Port Code	List Price*	Port Code	List Price*
D		D/S		.75 NPTF	.25 NPTF	.25 NPTF	D		D/S	
E		E/S		1.00 NPTF	.25 NPTF	.25 NPTF	E		E/S	
F		F/S		1.25 NPTF	.25 NPTF	.25 NPTF	F		F/S	
L		L/S		SAE-12	SAE-6	.25 NPTF	L		L/S	
M		M/S		SAE-16	SAE-6	.25 NPTF	M		M/S	
N		N/S		SAE-20	SAE-6	.25 NPTF	N		N/S	
W		W/S		.75 BSPP	.25 BSPP	.25 BSPP	W		W/S	
X		X/S		1.00 BSPP	.25 BSPP	.25 BSPP	X		X/S	
Y		Y/S		1.25 BSPP	.25 BSPP	.25 BSPP	Y		Y/S	

*For part number and price for body only contact your local SUN distributor.

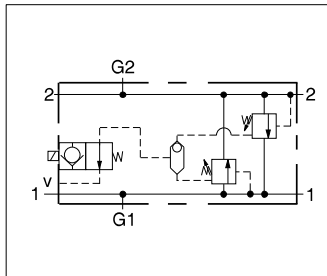

Normally Open
Solenoid Valve

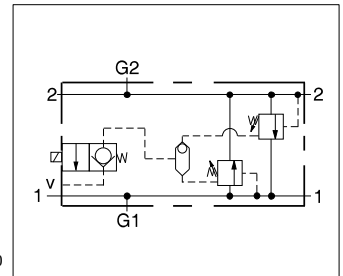
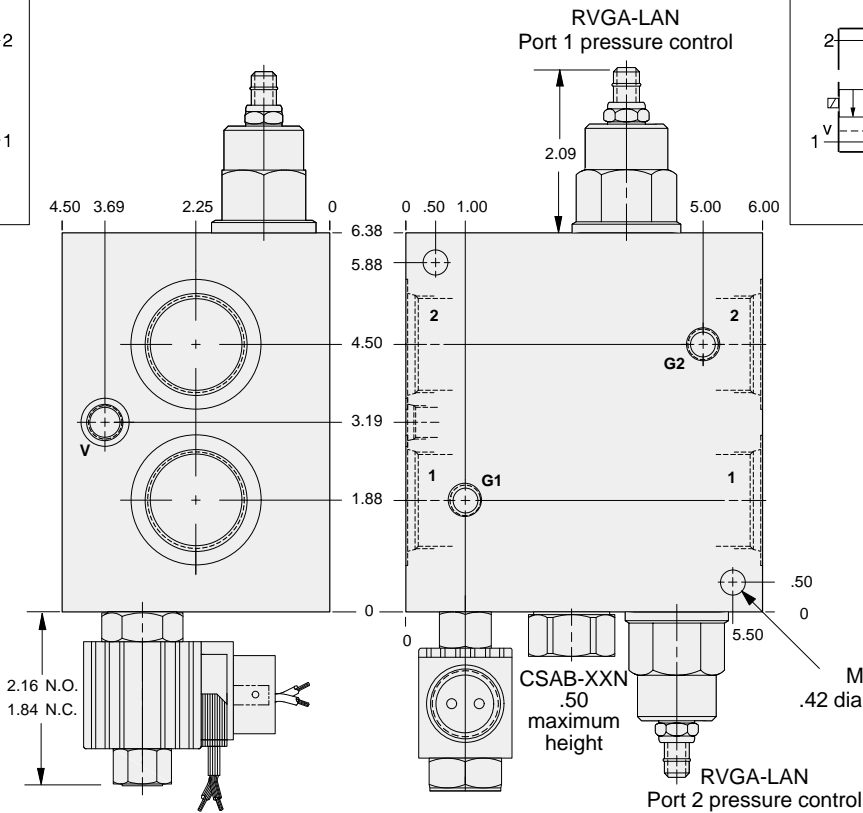

Normally Closed
Solenoid Valve

OPTIONS		YVF * - LAN **		
G Normally Open	CARTRIDGE RVGA Pg 1.19	J 12 volt DC, 24" leads	V 24 volt DC, ISO/DIN	PORTS See Chart above
H Normally Closed	For Viton Seals Change LAN to LAV. Customer Specified Setting Stamped on Hex	K 24 volt DC, 24" leads	V 230 volt, 50/60 Hz, ISO/DIN	
		N 115 volt, 50/60 Hz, conduit	W 120 volt, 50/60 Hz, ISO/DIN	
		O 230 volt, 50/60 Hz, conduit		
		S 12 volt DC, ISO/DIN		



CROSS-PORT RELIEF ASSEMBLY WITH SHUTTLE AND SOLENOID OPERATED VENT



- Maximum operating pressure 3000 psi.
- Power requirement: 12 watts.

YVFG: Normally Open

YVFH: Normally Closed

ALUMINUM		DUCTILE IRON		Mounting Hole Dimensions	Port V	Ports G1 & G2	ALUMINUM		DUCTILE IRON	
Port Code	List Price*	Port Code	List Price*				Port Code	List Price*	Port Code	List Price*
P		P/S		Inch	SAE-6	.25 NPTF	P		P/S	
P/M		P/T		Metric	.25 BSPP	.25 BSPP	P/M		P/T	

*For part number and price for body only contact your local SUN distributor.

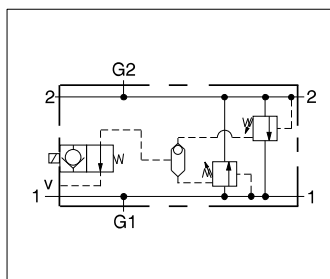

Normally Open Solenoid Valve

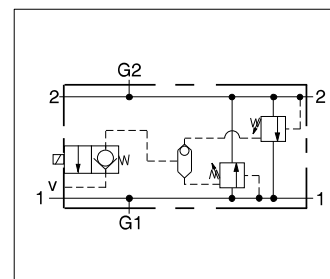

Normally Closed Solenoid Valve

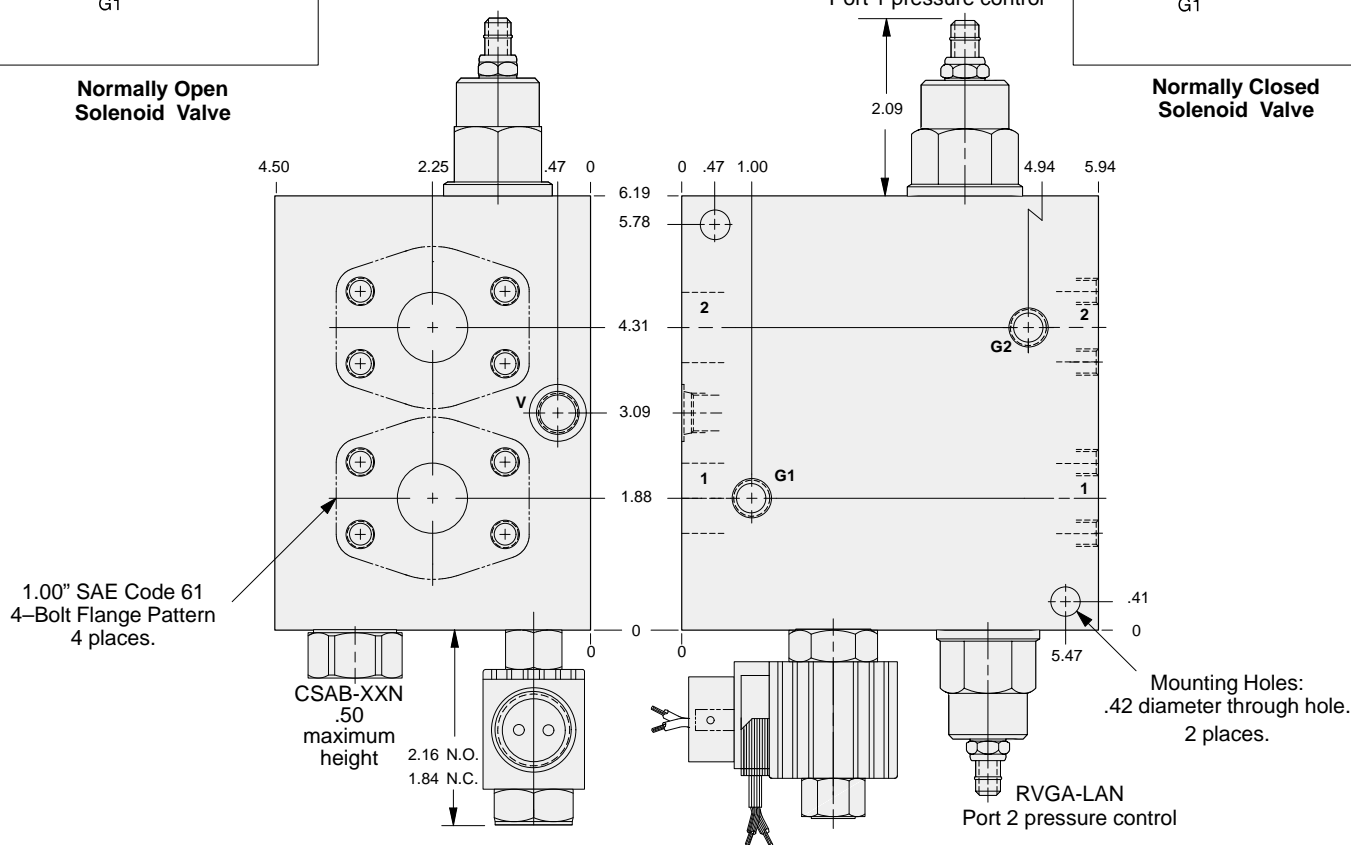

13

OPTIONS		YVF * - LAN - **		
G Normally Open	CARTRIDGES	J 12 volt DC, 24" leads	SOLENOID COILS	PORTS
H Normally Closed	RVGA Pg 1.19	K 24 volt DC, 24" leads	V 24 volt DC, ISO/DIN	See Chart above
	For Viton Seals Change LAN to LAV.	N 115 volt, 50/60 Hz, conduit	V 230 volt, 50/60 Hz, ISO/DIN	
	Customer Specified Setting Stamped on Hex	O 230 volt, 50/60 Hz, conduit	W 120 volt, 50/60 Hz, ISO/DIN	
		S 12 volt DC, ISO/DIN		



CROSS-PORT RELIEF ASSEMBLY WITH SHUTTLE AND SOLENOID OPERATED VENT



- Maximum operating pressure 3000 psi.
- Power requirement: 12 watts.

YVFG: Normally Open

YVFH: Normally Closed

ALUMINUM		DUCTILE IRON		Mounting Hole Dimensions	Port V	Ports G1 & G2	ALUMINUM		DUCTILE IRON	
Port Code	List Price*	Port Code	List Price*				Port Code	List Price*	Port Code	List Price*
Q		Q/S		Inch	SAE-6	.25 NPTF	Q		Q/S	
Q/M		Q/T		Metric	.25 BSPP	.25 BSPP	Q/M		Q/T	

*For part number and price for body only contact your local SUN distributor.

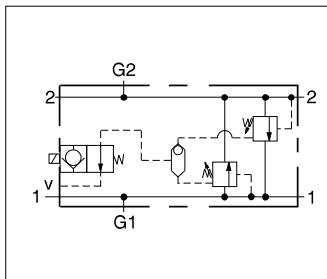

Normally Open Solenoid Valve

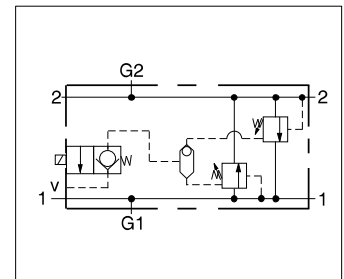

Normally Closed Solenoid Valve

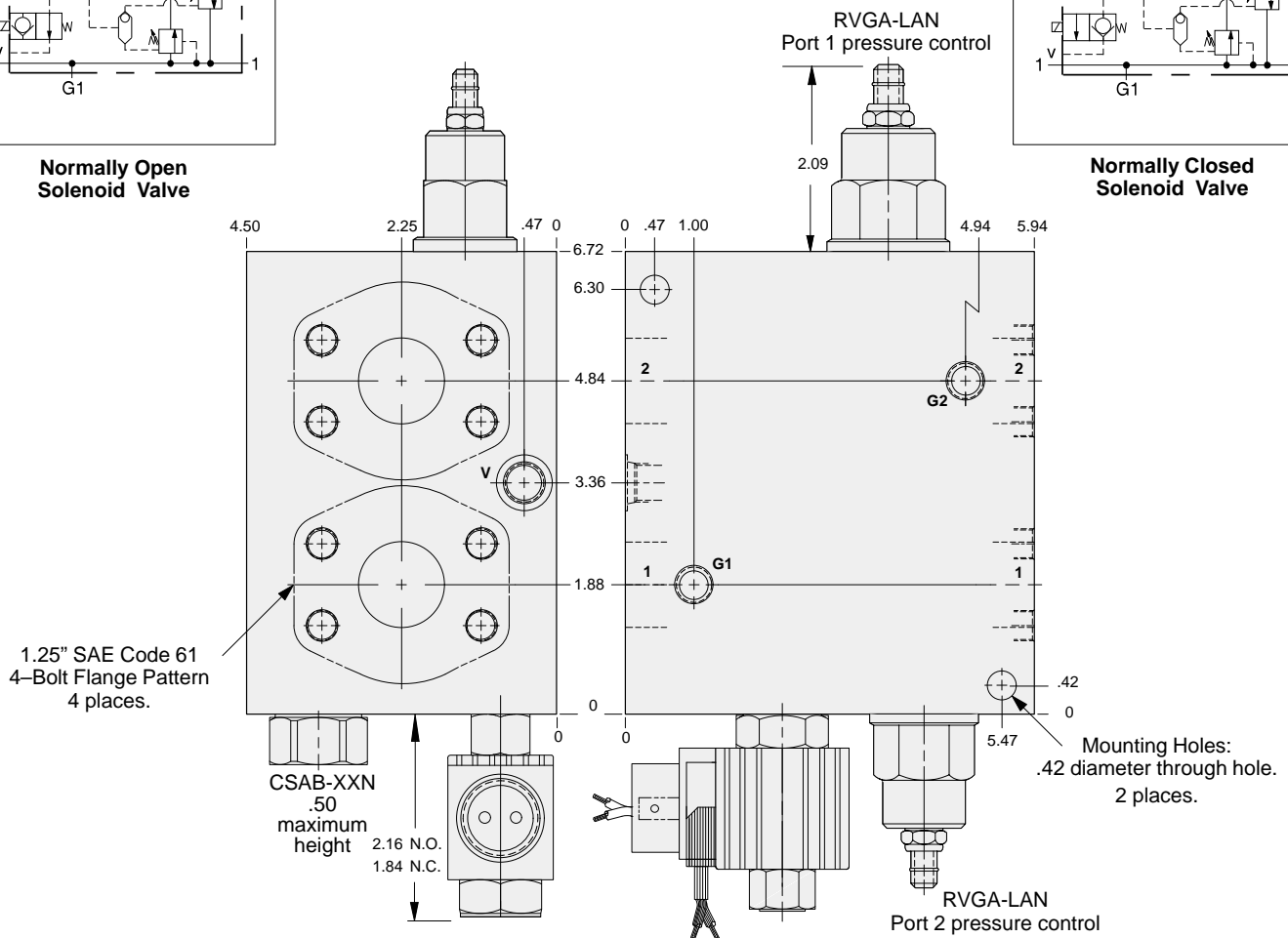

OPTIONS		YVF * - LAN - **		
G Normally Open	CARTRIDGES	J 12 volt DC, 24" leads	SOLENOID COILS	PORTS
H Normally Closed	RVGA Pg 1.19	K 24 volt DC, 24" leads	V 24 volt DC, ISO/DIN	See Chart above
	For Viton Seals Change LAN to LAV.	N 115 volt, 50/60 Hz, conduit	V 230 volt, 50/60 Hz, ISO/DIN	
	Customer Specified Setting Stamped on Hex	O 230 volt, 50/60 Hz, conduit	W 120 volt, 50/60 Hz, ISO/DIN	
		S 12 volt DC, ISO/DIN		



HYDROSTATIC TRANSMISSION ASSEMBLY INLINE BODY



- Aluminum rated to 3000 psi and Ductile Iron rated to 5000 psi.
- Hot oil pressure can be confirmed and/or set with transmission in neutral.

These SUN valve assemblies are for use with hydrostatic transmissions to provide overload relief valve protection for the main circuit in both directions. Additionally, an auxiliary shuttle valve allows bleeding of hot oil from the low pressure side. Hot oil can be cooled, filtered, or used as a source of oil for flushing other pump and motor cases. Hot oil is removed from the loop when the SUN RPEC cartridge is set below the hydrostatic charge pressure relief valve.

NOTE: A mechanical brake is recommended to positively lock any stopped live load.

Mounting Hole Dimensions	Ports 1 & 2	Port T	Ports G1, G2, & G3	ALUMINUM		DUCTILE IRON	
				Port Code	List Price*	Port Code	List Price*
Inch	SAE-12	SAE-8	.25 NPTF	L		L/S	
Metric	.75 BSPP	.375 BSPP	.25 BSPP	W		W/S	

*For part number and price for body only contact your local SUN distributor.

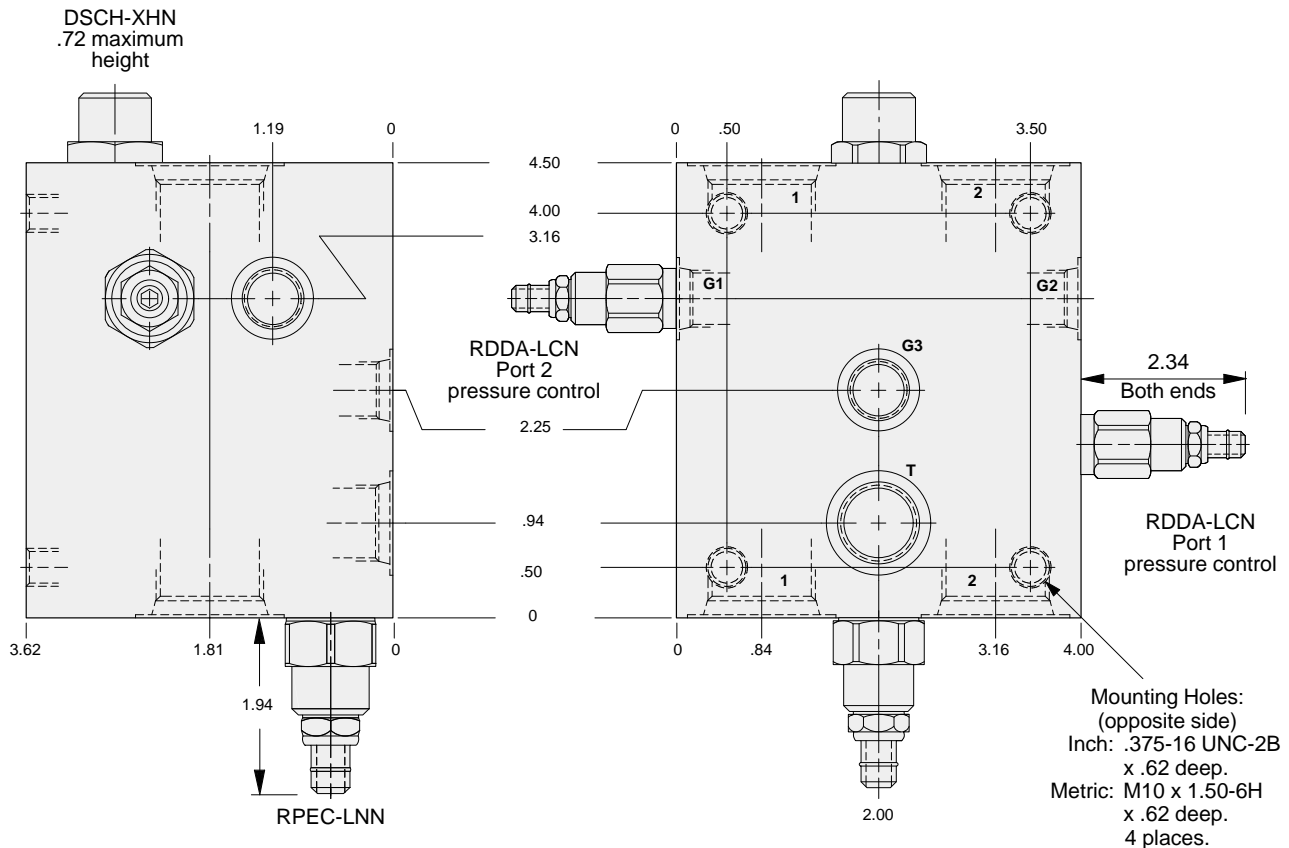
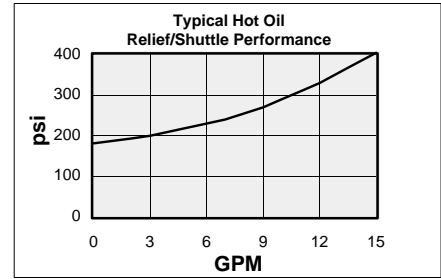
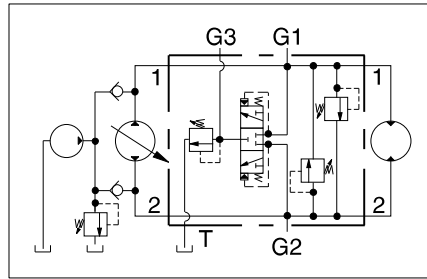

13

OPTIONS	XRDB - LCN - A*			
	CARTRIDGE RDDA Pg 1.10 For Viton Seals Change LCN to LCV.		Customer Specified Setting Stamped on Hex	PORTS See Chart above



HYDROSTATIC TRANSMISSION ASSEMBLY .75" SAE FLANGE PORT BODY



- Aluminum rated to 3000 psi and Ductile Iron rated to 5000 psi.
- Hot oil pressure can be confirmed and/or set with transmission in neutral.

Mounting Hole Dimensions	Ports 1 & 2	Port T	Ports G1, G2, & G3	ALUMINUM		DUCTILE IRON	
				Port Code	List Price*	Port Code	List Price*
Inch	Code 61	SAE-8	SAE-6	O		O/S	
Metric	Code 61	.375 BSPP	.25 BSPP	O/M		O/T	

*For part number and price for body only contact your local SUN distributor.

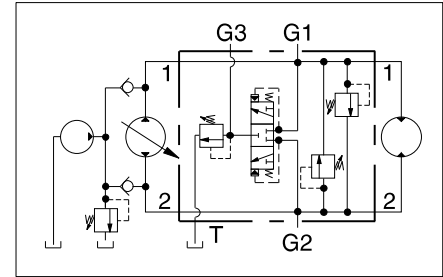

These SUN valve assemblies are for use with hydrostatic transmissions to provide overload relief valve protection for the main circuit in both directions. Additionally, an auxiliary shuttle valve allows bleeding of hot oil from the low pressure side. Hot oil can be cooled, filtered, or used as a source of oil for flushing other pump and motor cases. Hot oil is removed from the loop when the SUN RPEC cartridge is set below the hydrostatic charge pressure relief valve.

NOTE: A mechanical brake is recommended to positively lock any stopped live load.

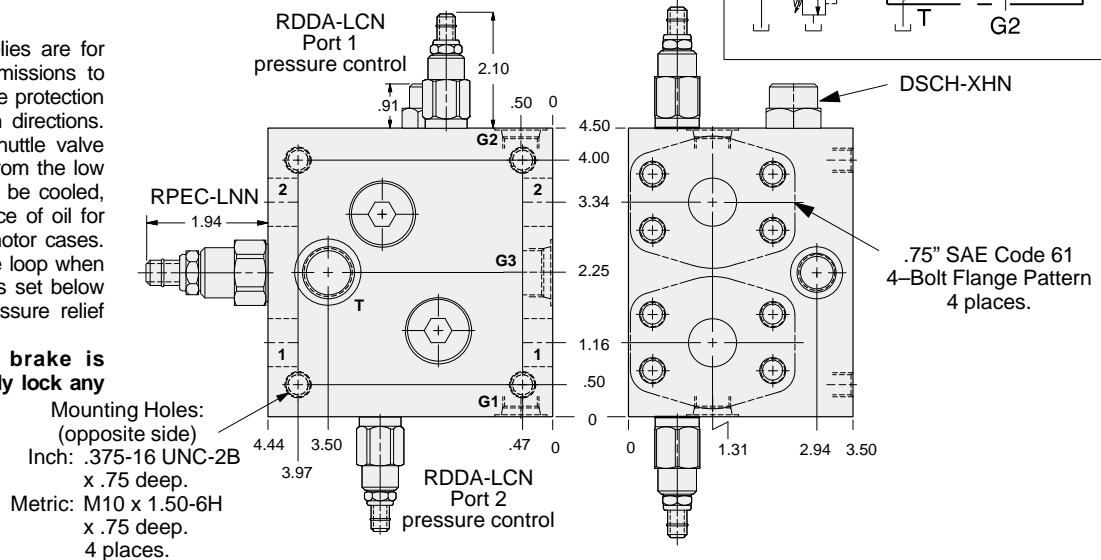

Mounting Hole Dimensions	Ports 1 & 2	Port T	Ports G1, G2, & G3	ALUMINUM		DUCTILE IRON	
				Port Code	List Price*	Port Code	List Price*
Inch	Code 62	SAE-8	SAE-6	3		3/S	
Metric	Code 62	.375 BSPP	.25 BSPP	3/M		3/T	

*For part number and price for body only contact your local SUN distributor.

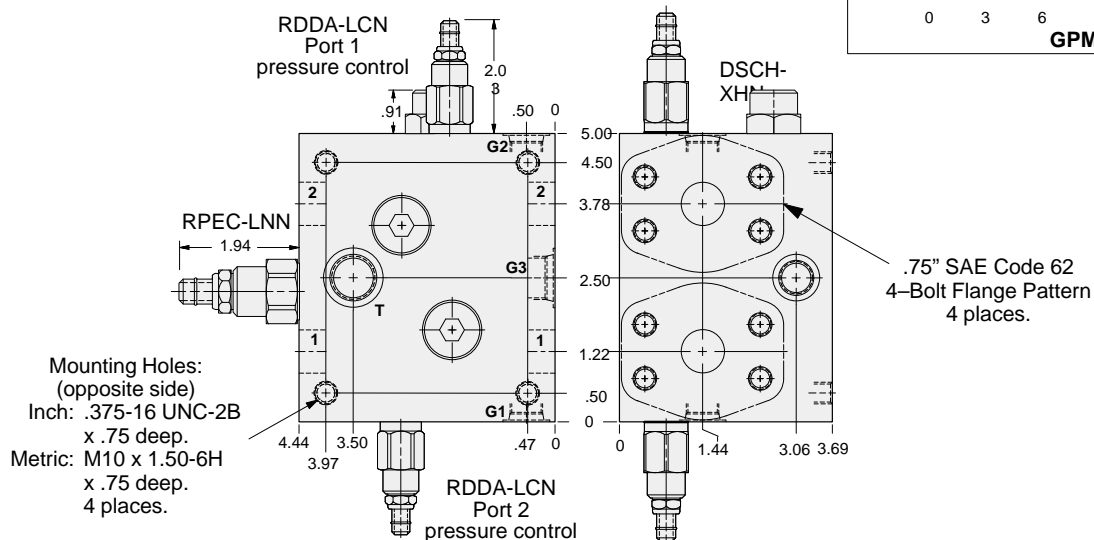
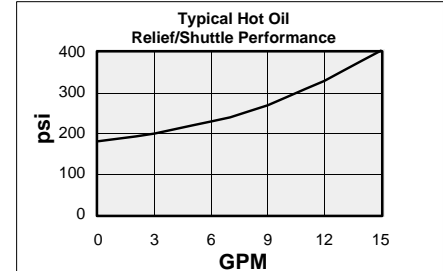

OPTIONS	XRDB - LCN - A*	PORTS
	CARTRIDGE RDDA Pg 1.10 For Viton Seals Change LCN to LCV.	See Chart above
	Customer Specified Setting Stamped on Hex	



HYDROSTATIC TRANSMISSION ASSEMBLY INLINE BODY



- Aluminum rated to 3000 psi and Ductile Iron rated to 5000 psi.
- Hot oil pressure can be confirmed and/or set with transmission in neutral.

These SUN valve assemblies are for use with hydrostatic transmissions to provide overload relief valve protection for the main circuit in both directions. Additionally, an auxiliary shuttle valve allows bleeding of hot oil from the low pressure side. Hot oil can be cooled, filtered, or used as a source of oil for flushing other pump and motor cases. Hot oil is removed from the loop when the SUN RPEC cartridge is set below the hydrostatic charge pressure relief valve.

NOTE: A mechanical brake is recommended to positively lock any stopped live load.

Mounting Hole Dimensions	Ports 1 & 2	Port T	Ports G1, G2, & G3	ALUMINUM		DUCTILE IRON	
				Port Code	List Price*	Port Code	List Price*
Inch	SAE-16	SAE-10	SAE-6	M		M/S	
Metric	1.00 BSPP	.50 BSPP	.25 BSPP	X		X/S	

*For part number and price for body only contact your local SUN distributor.

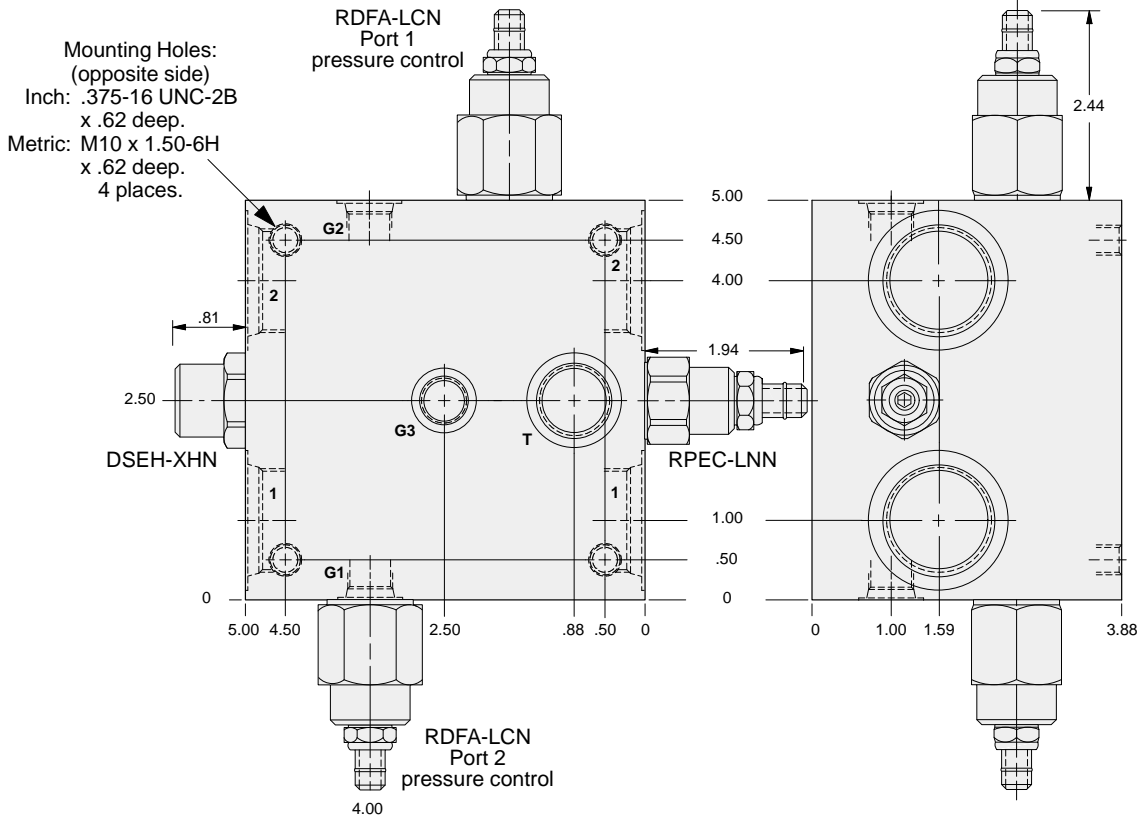
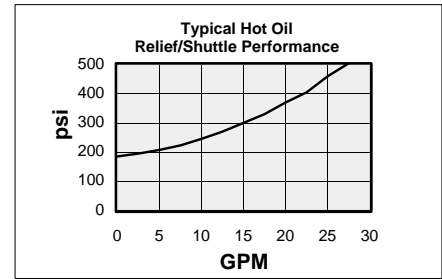
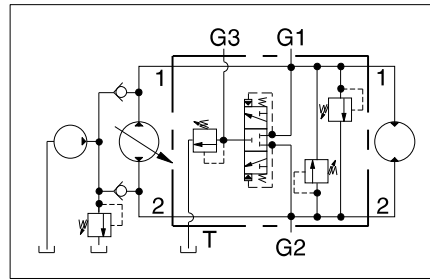

13

OPTIONS	XRFB - LCN - A*			
CARTRIDGE	RDFA Pg 1.10 For Viton Seals Change LCN to LCV.	Customer Specified Setting Stamped on Hex	PORTS	See Chart above



HYDROSTATIC TRANSMISSION ASSEMBLY 1.00" SAE FLANGE PORT BODY



- Aluminum rated to 3000 psi and Ductile Iron rated to 5000 psi.
- Hot oil pressure can be confirmed and/or set with transmission in neutral.

Mounting Hole Dimensions	Ports 1 & 2	Port T	Ports G1, G2, & G3	ALUMINUM		DUCTILE IRON	
				Port Code	List Price*	Port Code	List Price*
Inch	Code 61	SAE-10	SAE-6	P		P/S	
Metric	Code 61	.50 BSPP	.25 BSPP	P/M		P/T	

*For part number and price for body only contact your local SUN distributor.

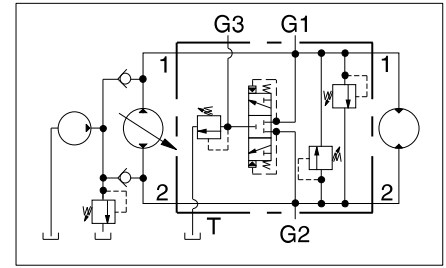

These SUN valve assemblies are for use with hydrostatic transmissions to provide overload relief valve protection for the main circuit in both directions. Additionally, an auxiliary shuttle valve allows bleeding of hot oil from the low pressure side. Hot oil can be cooled, filtered, or used as a source of oil for flushing other pump and motor cases. Hot oil is removed from the loop when the SUN RPEC cartridge is set below the hydrostatic charge pressure relief valve.

NOTE: A mechanical brake is recommended to positively lock any stopped live load.

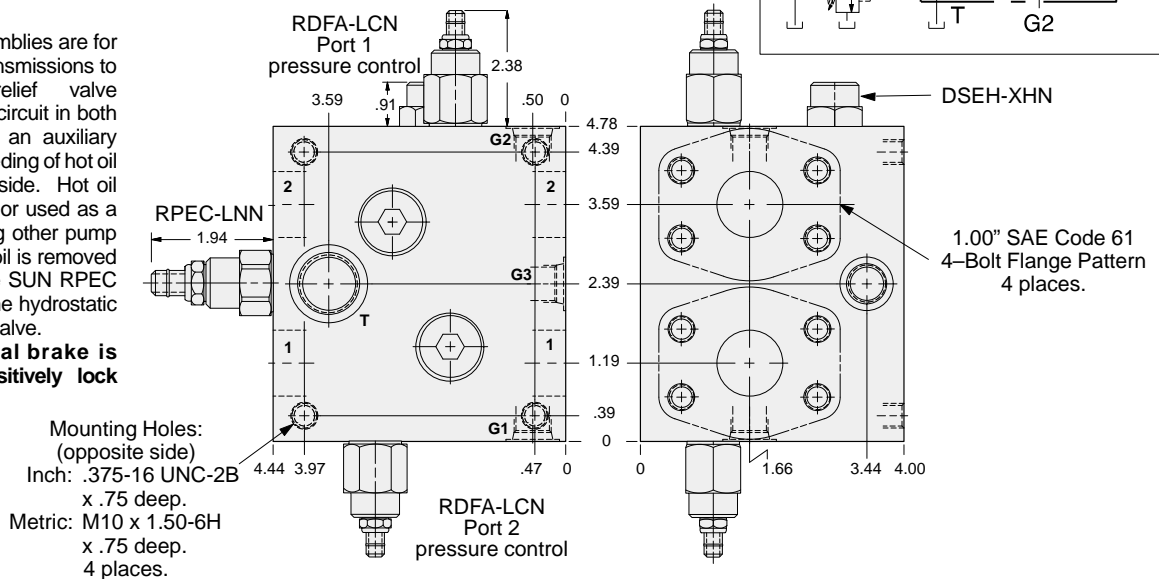

Mounting Hole Dimensions	Ports 1 & 2	Port T	Ports G1, G2, & G3	ALUMINUM		DUCTILE IRON	
				Port Code	List Price*	Port Code	List Price*
Inch	Code 62	SAE-10	SAE-6	4		4/S	
Metric	Code 62	.50 BSPP	.25 BSPP	4/M		4/T	

*For part number and price for body only contact your local SUN distributor.

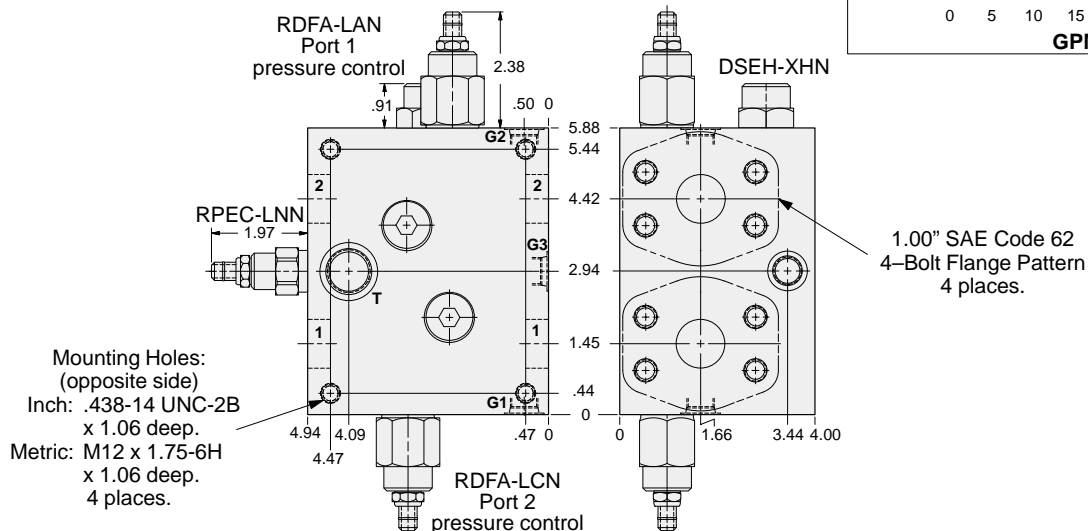
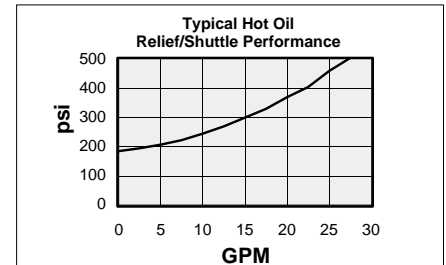

OPTIONS	XRFB - LCN - A*	
	CARTRIDGE	PORTS
	RDFA Pg 1.10 For Viton Seals Change LCN to LCV.	Customer Specified Setting Stamped on Hex See Chart above



HYDROSTATIC TRANSMISSION ASSEMBLY 1.25" SAE CODE 61 FLANGE PORT BODY



- Aluminum rated to 3000 psi and Ductile Iron rated to 5000 psi.
- Hot oil pressure can be confirmed and/or set with transmission in neutral.

These SUN valve assemblies are for use with hydrostatic transmissions to provide overload relief valve protection for the main circuit in both directions. Additionally, an auxiliary shuttle valve allows bleeding of hot oil from the low pressure side. Hot oil can be cooled, filtered, or used as a source of oil for flushing other pump and motor cases. Hot oil is removed from the loop when the SUN RPEC cartridge is set below the hydrostatic charge pressure relief valve.

NOTE: A mechanical brake is recommended to positively lock any stopped live load.

Mounting Hole Dimensions	Port T	Ports G1, G2, & G3	ALUMINUM		DUCTILE IRON	
			Port Code	List Price*	Port Code	List Price*
Inch	SAE-12	SAE-6	Q		Q/S	
Metric	.75 BSPP	.25 BSPP	Q/M		Q/T	

*For part number and price for body only contact your local SUN distributor.

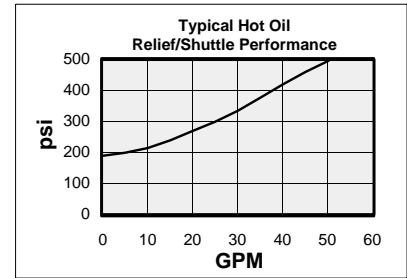
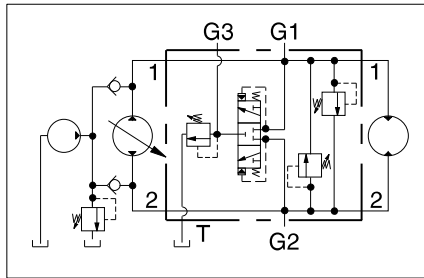

13

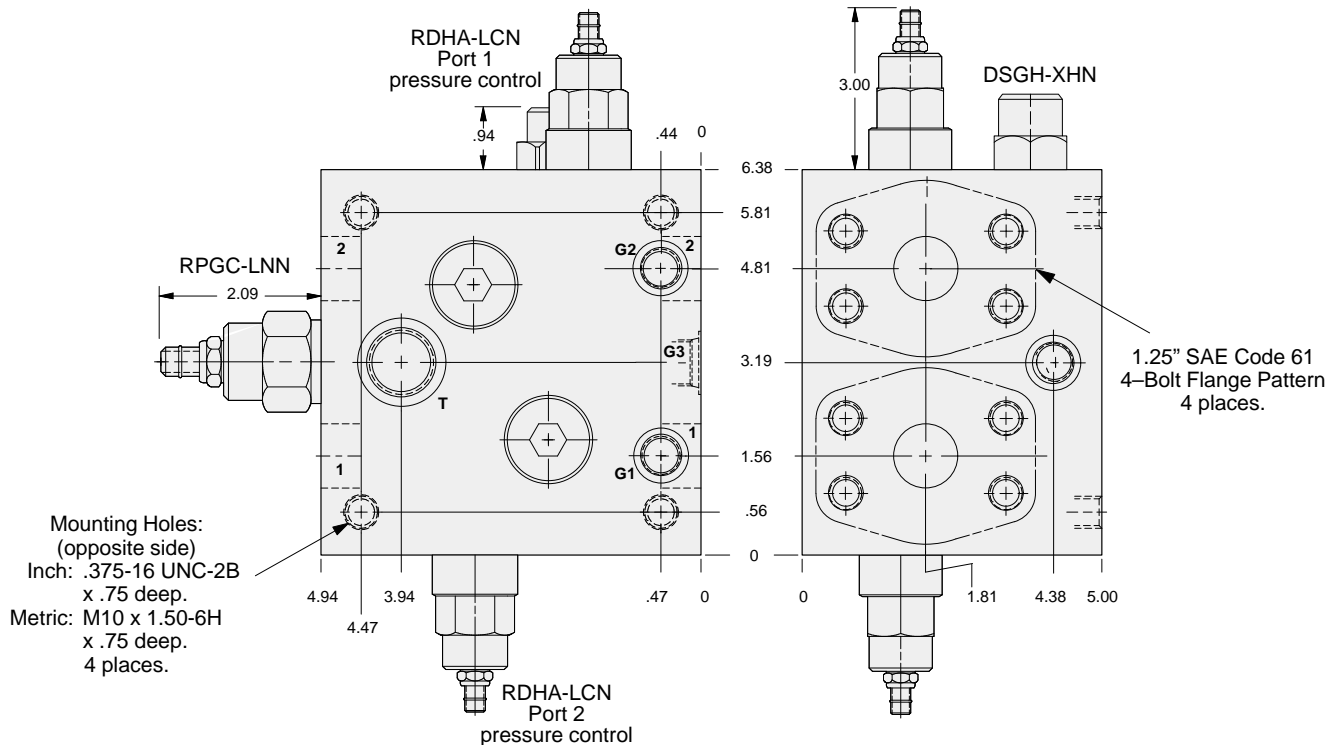

OPTIONS	XRHB - LCN - A*	
	CARTRIDGE RDHA Pg 1.11 For Viton Seals Change LCN to LCV.	PORTS See Chart above
	Customer Specified Setting Stamped on Hex	



HYDROSTATIC TRANSMISSION ASSEMBLY 1.25" SAE CODE 62 FLANGE PORT BODY



- Aluminum rated to 3000 psi and Ductile Iron rated to 5000 psi.
- Hot oil pressure can be confirmed and/or set with transmission in neutral.

These SUN valve assemblies are for use with hydrostatic transmissions to provide overload relief valve protection for the main circuit in both directions. Additionally, an auxiliary shuttle valve allows bleeding of hot oil from the low pressure side. Hot oil can be cooled, filtered, or used as a source of oil for flushing other pump and motor cases. Hot oil is removed from the loop when the SUN RPEC cartridge is set below the hydrostatic charge pressure relief valve.

NOTE: A mechanical brake is recommended to positively lock any stopped live load.

Mounting Hole Dimensions	Port T	Ports G1, G2, & G3	ALUMINUM		DUCTILE IRON	
			Port Code	List Price*	Port Code	List Price*
Inch	SAE-12	SAE-6	5		5/S	
Metric	.75 BSPP	.25 BSPP	5/M		5/T	

*For part number and price for body only contact your local SUN distributor.

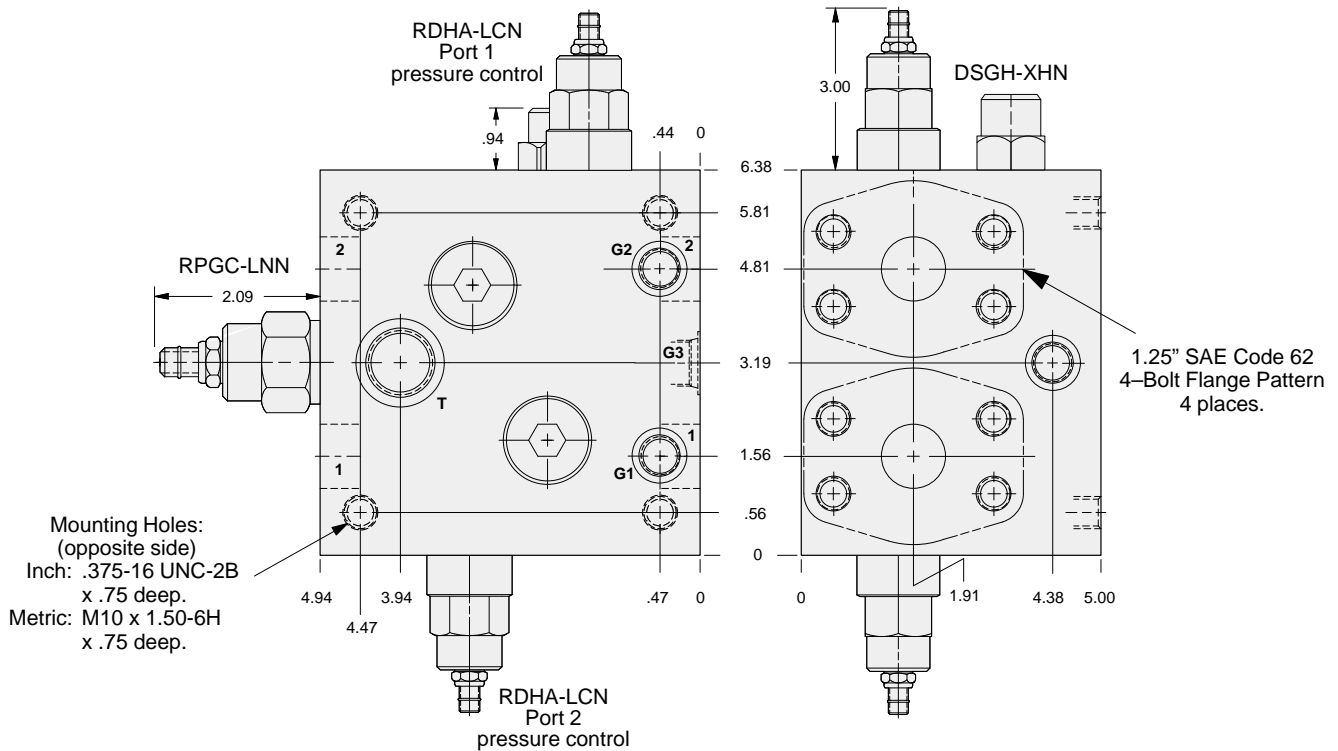
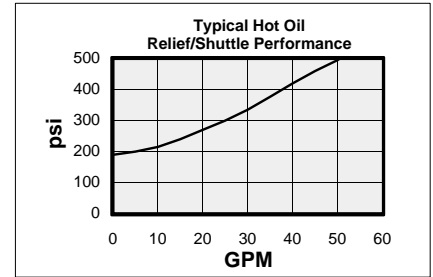
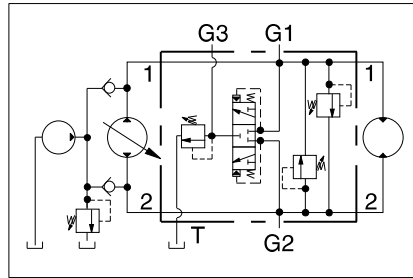

13

OPTIONS	XRHB - LCN - A*		
	CARTRIDGE	Customer Specified Setting Stamped on Hex	PORTS
	RDHA Pg 1.11 For Viton Seals Change LCN to LCV.		See Chart above



HYDROSTATIC TRANSMISSION ASSEMBLY 1.50" SAE FLANGE PORT BODY



- Aluminum rated to 3000 psi and Ductile Iron rated to 5000 psi.
- Hot oil pressure can be confirmed and/or set with transmission in neutral.

Mounting Hole Dimensions	Ports 1 & 2	Port T	Ports G1, G2, & G3	ALUMINUM		DUCTILE IRON	
				Port Code	List Price*	Port Code	List Price*
Inch	Code 61	SAE-16	SAE-6	R		R/S	
Metric	Code 61	1.00 BSPP	.25 BSPP	R/M		R/T	

*For part number and price for body only contact your local SUN distributor.

These SUN valve assemblies are for use with hydrostatic transmissions to provide overload relief valve protection for the main circuit in both directions. Additionally, an auxiliary shuttle valve allows bleeding of hot oil from the low pressure side. Hot oil can be cooled, filtered, or used as a source of oil for flushing other pump and motor cases. Hot oil is removed from the loop when the SUN RPEC cartridge is set below the hydrostatic charge pressure relief valve.

NOTE: A mechanical brake is recommended to positively lock any stopped live load.

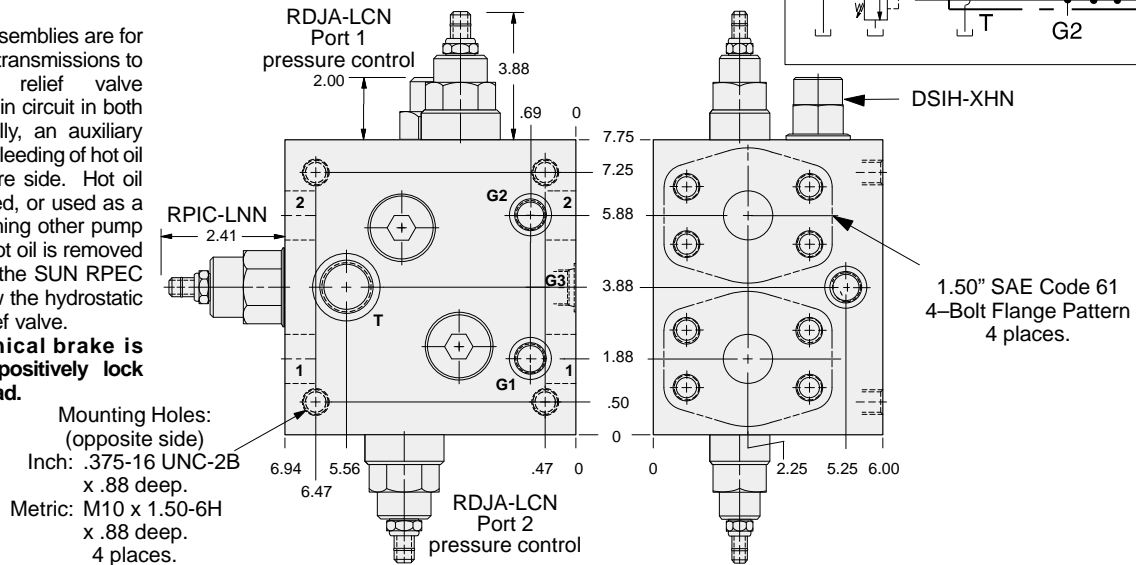

Mounting Hole Dimensions	Ports 1 & 2	Port T	Ports G1, G2, & G3	ALUMINUM		DUCTILE IRON	
				Port Code	List Price*	Port Code	List Price*
Inch	Code 62	SAE-16	SAE-6	6		6/S	
Metric	Code 62	1.00 BSPP	.25 BSPP	6/M		6/T	

*For part number and price for body only contact your local SUN distributor.

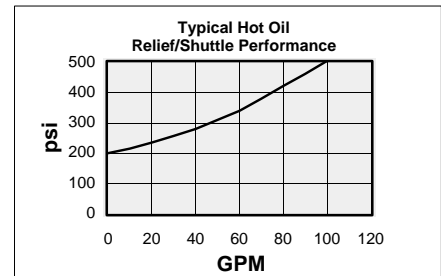

13

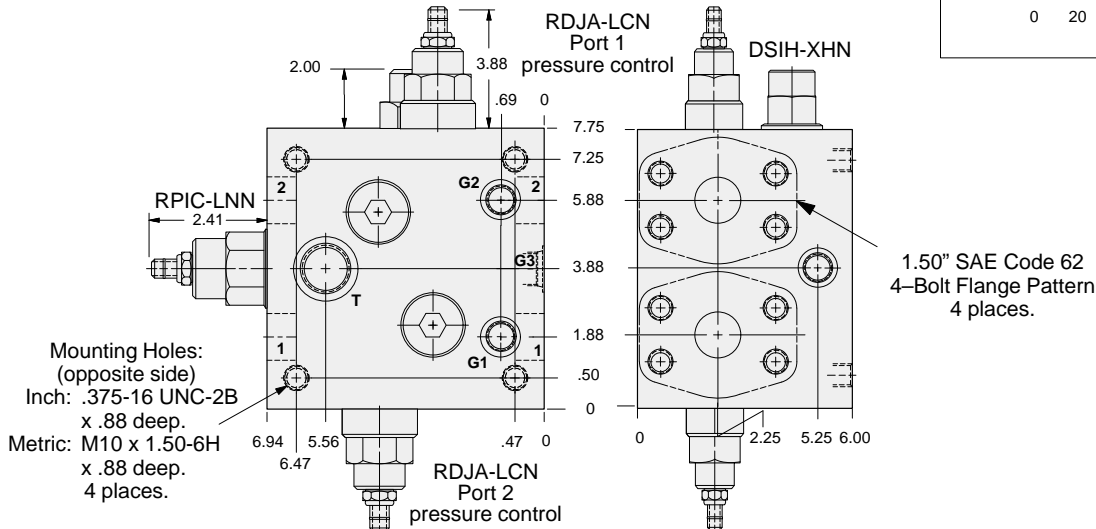

OPTIONS	XRJB - LCN - A*			
	CARTRIDGE RDJA Pg 1.11 For Viton Seals Change LCN to LCV.		Customer Specified Setting Stamped on Hex	PORTS See Chart above



HYDROSTATIC TRANSMISSION ASSEMBLY 2.00" SAE FLANGE PORT BODY



- Aluminum rated to 3000 psi and Ductile Iron rated to 5000 psi.
- Hot oil pressure can be confirmed and/or set with transmission in neutral.

Mounting Hole Dimensions	Ports 1 & 2	Port T	Ports G1, G2, & G3	ALUMINUM		DUCTILE IRON	
				Port Code	List Price*	Port Code	List Price*
Inch	Code 61	SAE-16	SAE-6	S		S/S	
Metric	Code 61	1.00 BSPP	.25 BSPP	S/M		S/T	

*For part number and price for body only contact your local SUN distributor.

These SUN valve assemblies are for use with hydrostatic transmissions to provide overload relief valve protection for the main circuit in both directions. Additionally, an auxiliary shuttle valve allows bleeding of hot oil from the low pressure side. Hot oil can be cooled, filtered, or used as a source of oil for flushing other pump and motor cases. Hot oil is removed from the loop when the SUN RPEC cartridge is set below the hydrostatic charge pressure relief valve.

NOTE: A mechanical brake is recommended to positively lock any stopped live load.

Mounting Holes:
(opposite side)
Inch: .375-16 UNC-2B
x .88 deep.
Metric: M10 x 1.50-6H
x .88 deep.
4 places.

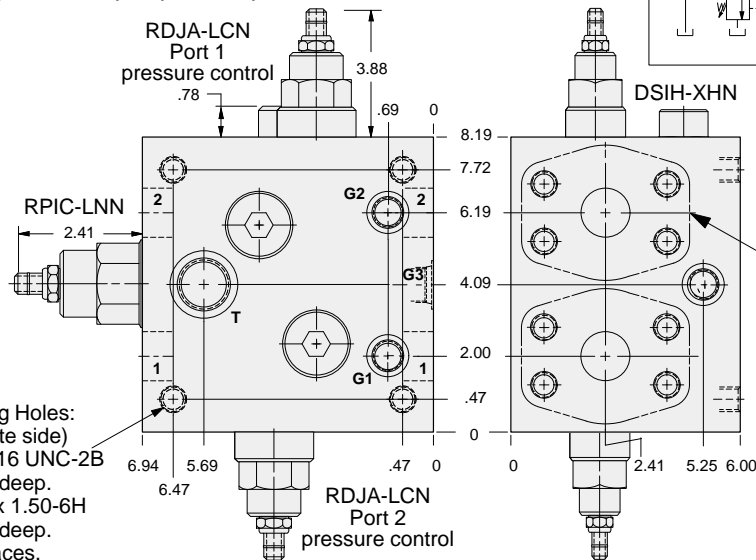

2.00" SAE Code 61
4-Bolt Flange Pattern
4 places.

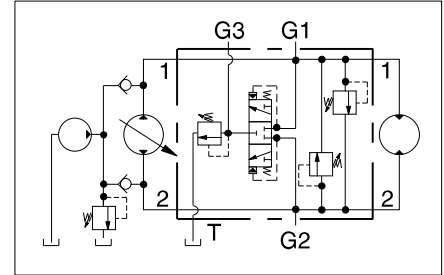

Mounting Hole Dimensions	Ports 1 & 2	Port T	Ports G1, G2, & G3	ALUMINUM		DUCTILE IRON	
				Port Code	List Price*	Port Code	List Price*
Inch	Code 62	SAE-16	SAE-6	8		8/S	
Metric	Code 62	1.00 BSPP	.25 BSPP	8/M		8/T	

*For part number and price for body only contact your local SUN distributor.

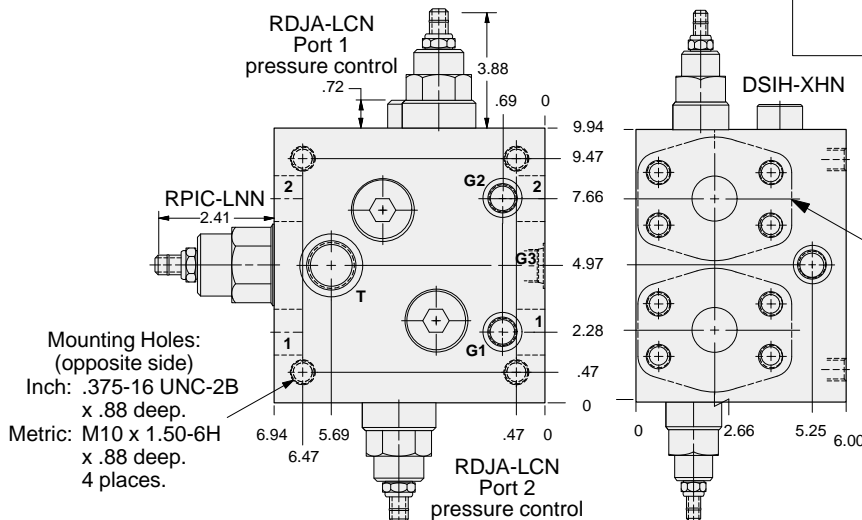
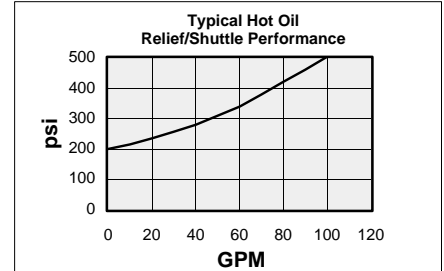

2.00" SAE Code 62
4-Bolt Flange Pattern
4 places.

OPTIONS	XRJB - LCN - A*	PORTS
CARTRIDGE RDJA Pg 1.11 For Viton Seals Change LCN to LCV.		Customer Specified Setting Stamped on Hex
		See Chart above



HOT OIL SHUTTLE AND RELIEF ASSEMBLY INLINE BODY



- Aluminum rated to 3000 psi and Ductile Iron rated to 5000 psi.
- Hot oil pressure can be confirmed and/or set with transmission in neutral.

These SUN valve assemblies are for use in bleeding hot oil from the low pressure side of a hydrostatic transmission circuit. The hot oil can be cooled, filtered, or used as a source of oil for flushing other pump and motor cases. The hot oil is removed from the loop when the SUN RPEC cartridge is set below the hydrostatic charge pressure relief valve.

Mounting Hole Dimensions	Ports 1 & 2	Port T	Gage Port	ALUMINUM		DUCTILE IRON	
				Port Code	List Price*	Port Code	List Price*
Inch	SAE-10	SAE-8	SAE-6	K		K/S	
Inch	SAE-12	SAE-8	SAE-6	L		L/S	
Metric	.50 BSPP	.375 BSPP	.25 BSPP	V		V/S	
Metric	.75 BSPP	.375 BSPP	.25 BSPP	W		W/S	

*For part number and price for body only contact your local SUN distributor.

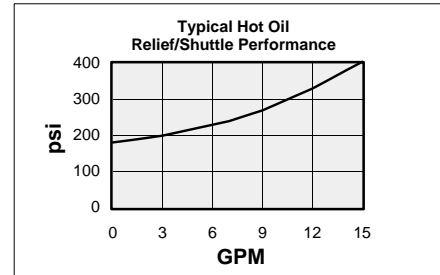
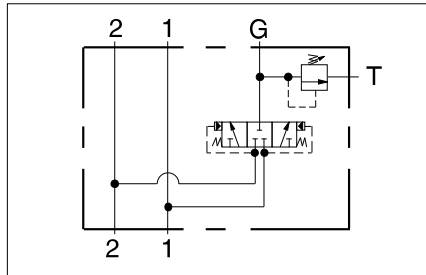

13

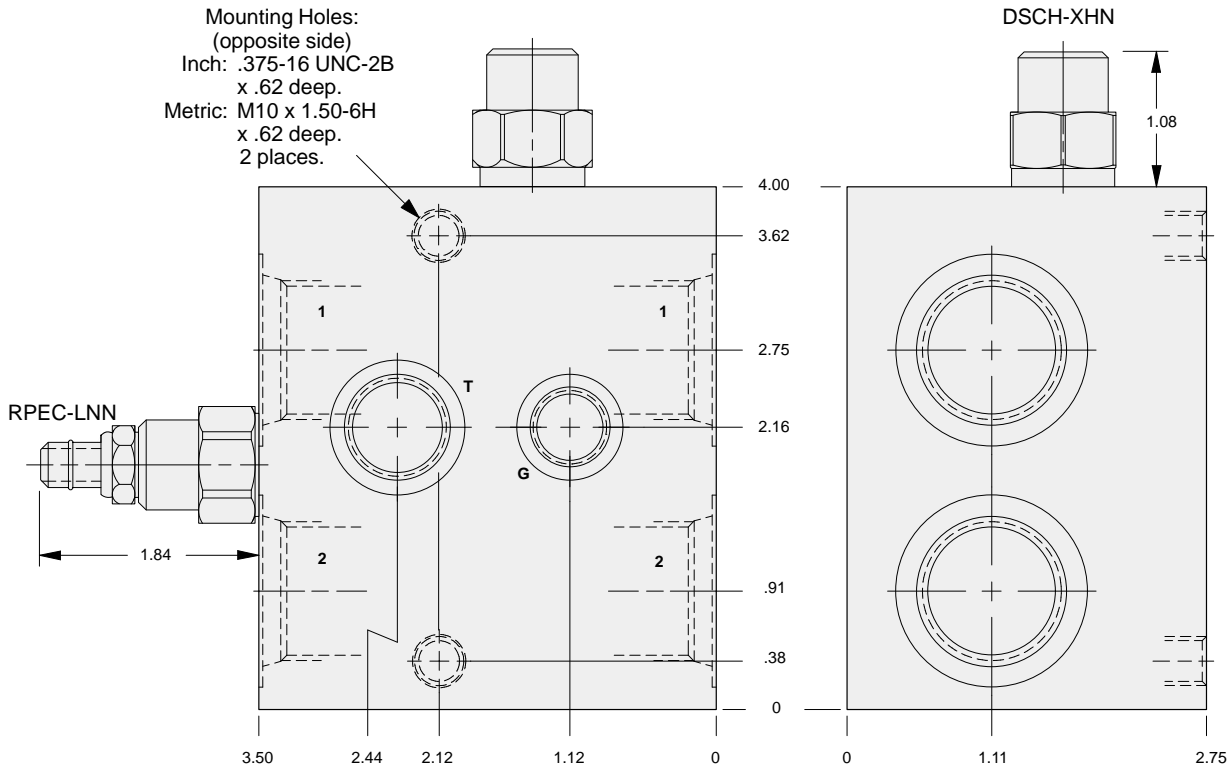

OPTIONS	XRDC - LNN - A*		
	CARTRIDGE RPEC Pg 1.06 For Viton Seals Change LNN to LNV.	Customer Specified Setting Stamped on Hex	PORTS See Chart above



HOT OIL SHUTTLE AND RELIEF ASSEMBLY .75" SAE FLANGE PORT BODY



- Aluminum rated to 3000 psi and Ductile Iron rated to 5000 psi.
- Hot oil pressure can be confirmed and/or set with transmission in neutral.

Mounting Hole Dimensions	Ports 1 & 2	Port T	Gage Port	ALUMINUM		DUCTILE IRON	
				Port Code	List Price*	Port Code	List Price*
Inch	Code 61	SAE-8	SAE-6	O		O/S	
Metric	Code 61	.375 BSPP	.25 BSPP	O/M		O/T	

*For part number and price for body only contact your local SUN distributor.

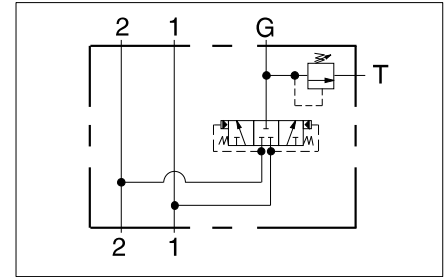

These SUN valve assemblies are for use in bleeding hot oil from the low pressure side of a hydrostatic transmission circuit. The hot oil can be cooled, filtered, or used as a source of oil for flushing other pump and motor cases. The hot oil is removed from the loop when the SUN RPEC cartridge is set below the hydrostatic charge pressure relief valve.

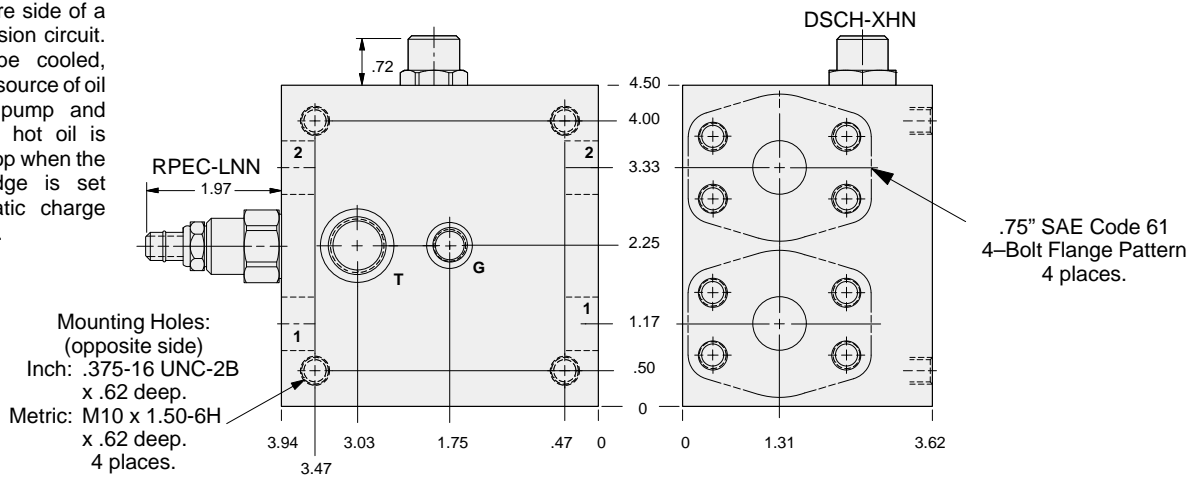

Mounting Hole Dimensions	Ports 1 & 2	Port T	Gage Port	ALUMINUM		DUCTILE IRON	
				Port Code	List Price*	Port Code	List Price*
Inch	Code 62	SAE-8	SAE-6	3		3/S	
Metric	Code 62	.375 BSPP	.25 BSPP	3/M		3/T	

*For part number and price for body only contact your local SUN distributor.

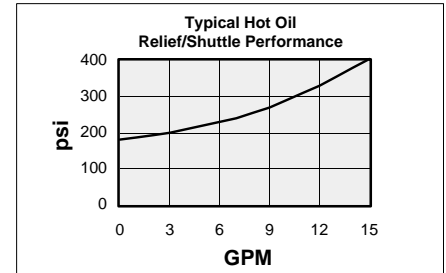

13

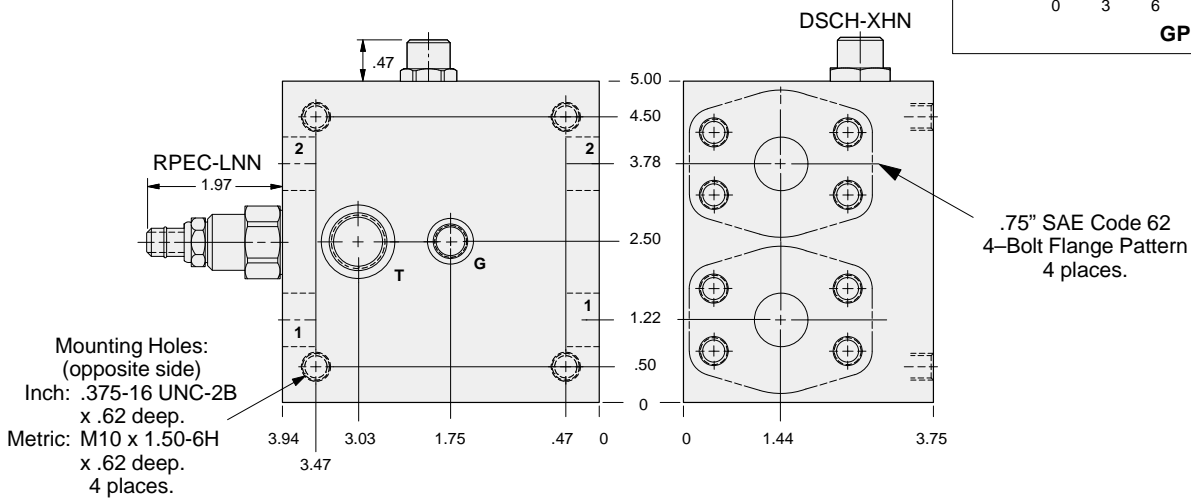

OPTIONS		XRDC - LNN - A*	
CARTRIDGE	RPEC Pg 1.06 For Viton Seals Change LNN to LNV.	Customer Specified Setting Stamped on Hex	PORTS See Chart above



HOT OIL SHUTTLE AND RELIEF ASSEMBLY INLINE BODY



- Aluminum rated to 3000 psi and Ductile Iron rated to 5000 psi.
- Hot oil pressure can be confirmed and/or set with transmission in neutral.

These SUN valve assemblies are for use in bleeding hot oil from the low pressure side of a hydrostatic transmission circuit. The hot oil can be cooled, filtered, or used as a source of oil for flushing other pump and motor cases. The hot oil is removed from the loop when the SUN RPEC cartridge is set below the hydrostatic charge pressure relief valve.

Mounting Hole Dimensions	Ports 1 & 2	Port T	Gage Port	ALUMINUM		DUCTILE IRON	
				Port Code	List Price*	Port Code	List Price*
Inch	SAE-12	SAE-10	SAE-6	L		L/S	
Inch	SAE-16	SAE-10	SAE-6	M		M/S	
Metric	.75 BSPP	.50 BSPP	.25 BSPP	W		W/S	
Metric	1.00 BSPP	.50 BSPP	.25 BSPP	X		X/S	

*For part number and price for body only contact your local SUN distributor.

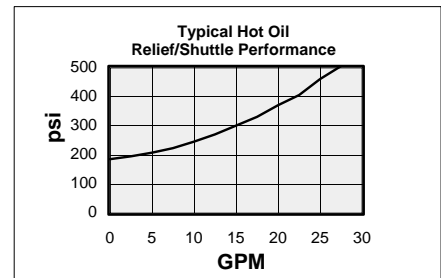
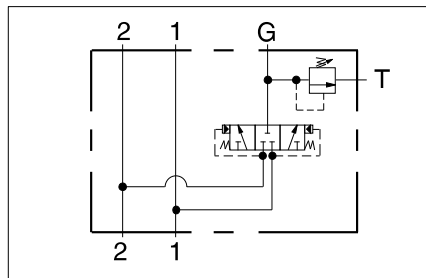

Mounting Holes:
(opposite side)
Inch: .375-16 UNC-2B
x .62 deep.
Metric: M10 x 1.50-6H
x .62 deep.
2 places.

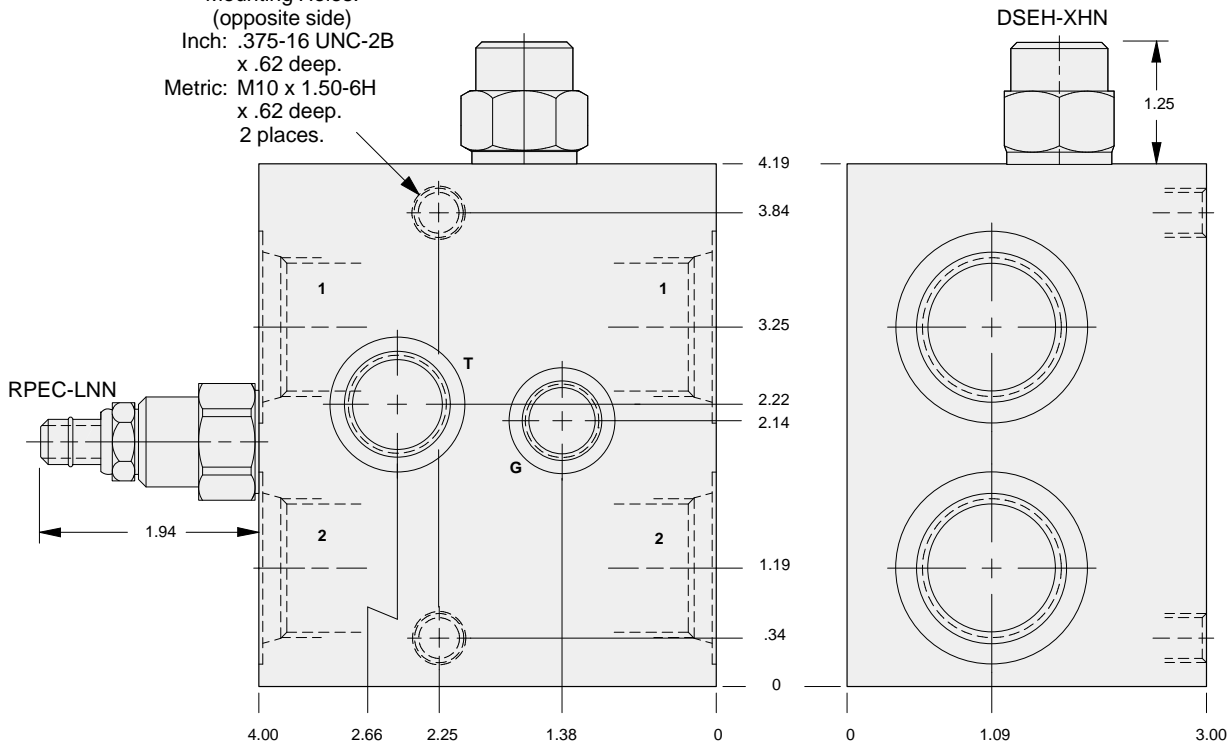

13

OPTIONS	XRFC - LNN - A*		
	CARTRIDGE	PORTS	
	RPEC Pg 1.06 For Viton Seals Change LNN to LNV.	Customer Specified Setting Stamped on Hex	See Chart above



HOT OIL SHUTTLE AND RELIEF ASSEMBLY 1.00" SAE FLANGE PORT BODY



- Aluminum rated to 3000 psi and Ductile Iron rated to 5000 psi.
- Hot oil pressure can be confirmed and/or set with transmission in neutral.

Mounting Hole Dimensions	Ports 1 & 2	Port T	Gage Port	ALUMINUM		DUCTILE IRON	
				Port Code	List Price*	Port Code	List Price*
Inch	Code 61	SAE-10	SAE-6	P		P/S	
Metric	Code 61	.50 BSPP	.25 BSPP	P/M		P/T	

*For part number and price for body only contact your local SUN distributor.

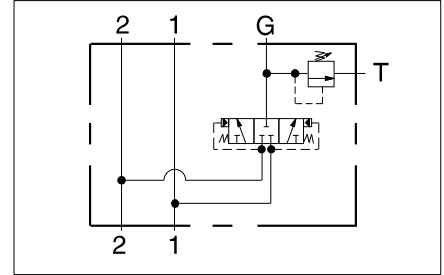

These SUN valve assemblies are for use in bleeding hot oil from the low pressure side of a hydrostatic transmission circuit. The hot oil can be cooled, filtered, or used as a source of oil for flushing other pump and motor cases. The hot oil is removed from the loop when the SUN RPEC cartridge is set below the hydrostatic charge pressure relief valve.

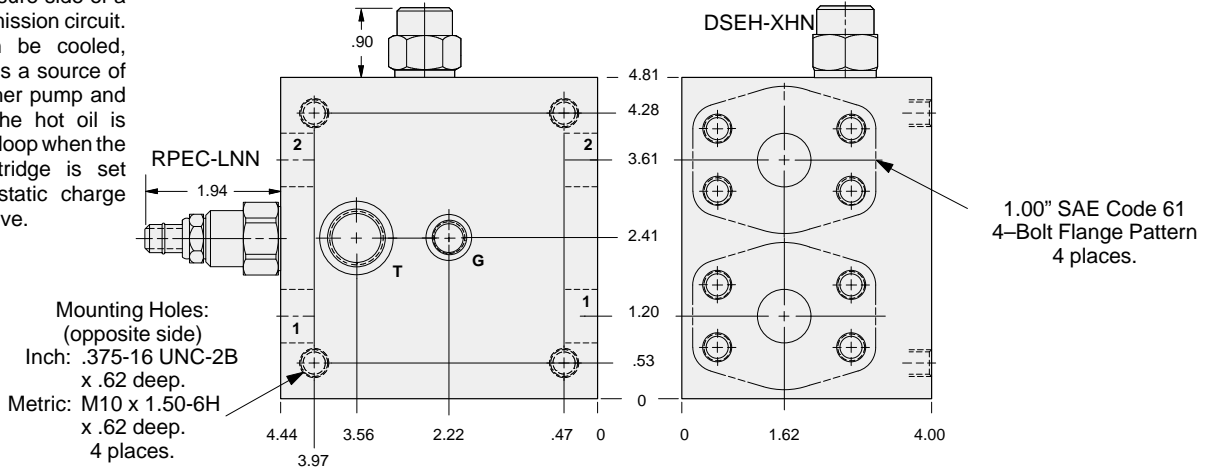

Mounting Hole Dimensions	Ports 1 & 2	Port T	Gage Port	ALUMINUM		DUCTILE IRON	
				Port Code	List Price*	Port Code	List Price*
Inch	Code 62	SAE-10	SAE-6	4		4/S	
Metric	Code 62	.50 BSPP	.25 BSPP	4/M		4/T	

*For part number and price for body only contact your local SUN distributor.

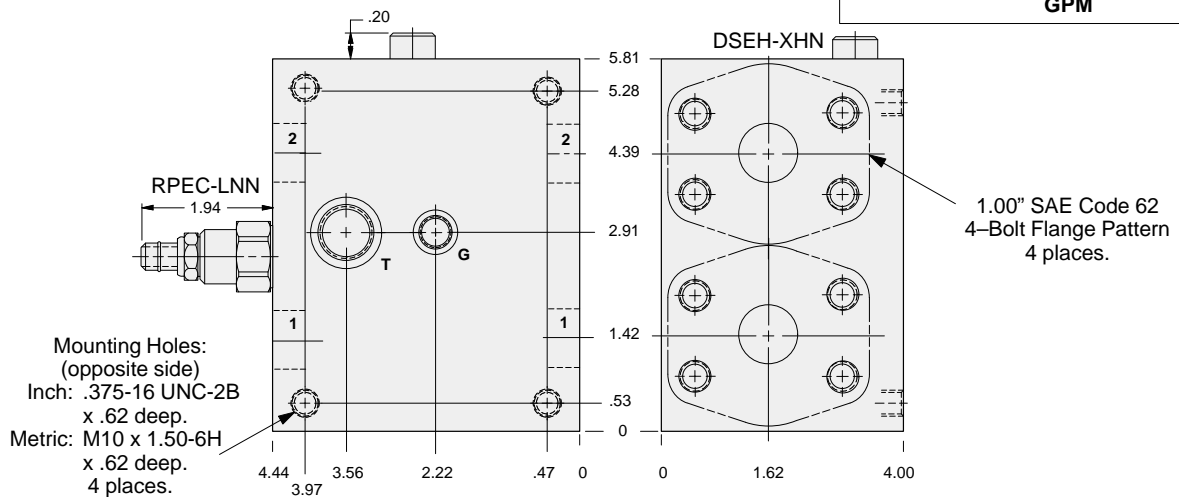
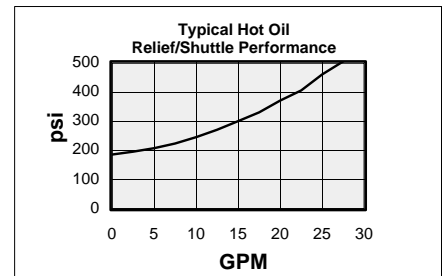

OPTIONS	XRFC - LNN - A*	PORTS
CARTRIDGE RPEC Pg 1.06 For Viton Seals Change LNN to LNV.	Customer Specified Setting Stamped on Hex	See Chart above



HOT OIL SHUTTLE AND RELIEF ASSEMBLY INLINE BODY



- Aluminum rated to 3000 psi and Ductile Iron rated to 5000 psi.
- Hot oil pressure can be confirmed and/or set with transmission in neutral.

These SUN valve assemblies are for use in bleeding hot oil from the low pressure side of a hydrostatic transmission circuit. The hot oil can be cooled, filtered, or used as a source of oil for flushing other pump and motor cases. The hot oil is removed from the loop when the SUN RPEC cartridge is set below the hydrostatic charge pressure relief valve.

Mounting Hole Dimensions	Ports 1 & 2	Port T	Gage Port	ALUMINUM		DUCTILE IRON	
				Port Code	List Price*	Port Code	List Price*
Inch	SAE-16	SAE-12	SAE-6	M		M/S	
Metric	1.00 BSPB	.75 BSBP	.25 BSBP	X		X/S	

*For part number and price for body only contact your local SUN distributor.

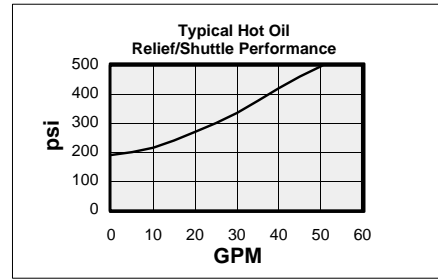
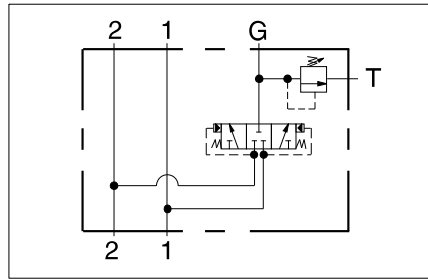

Mounting Holes:
(opposite side)
Inch: .375-16 UNC-2B
x .62 deep.
Metric: M10 x 1.50-6H
x .62 deep.
2 places.

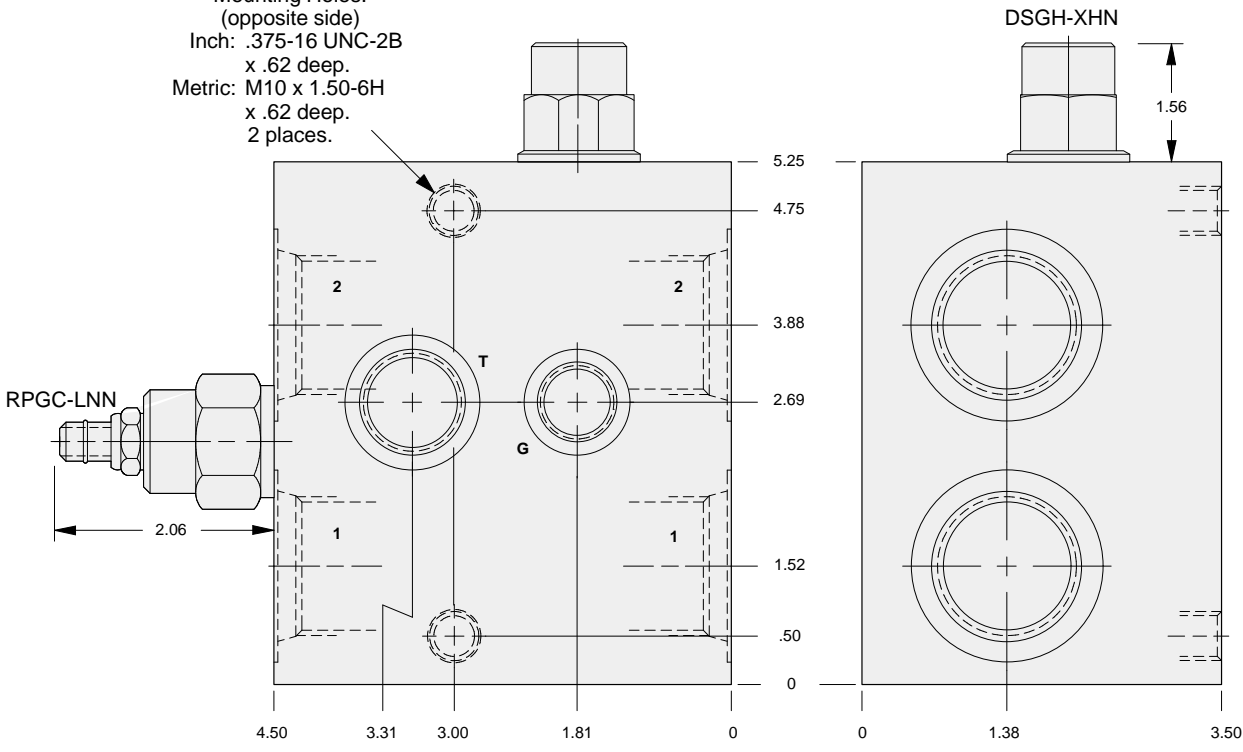

13

OPTIONS	XRHC - LNN - A*		
CARTRIDGE	PORTS		
RPGC Pg 1.06 For Viton Seals Change LNN to LNV.	Customer Specified Setting Stamped on Hex	See Chart above	



HOT OIL SHUTTLE AND RELIEF ASSEMBLY 1.25" SAE FLANGE PORT BODY



- Aluminum rated to 3000 psi and Ductile Iron rated to 5000 psi.
- Hot oil pressure can be confirmed and/or set with transmission in neutral.

Mounting Hole Dimensions	Ports 1 & 2	Port T	Gage Port	ALUMINUM		DUCTILE IRON	
				Port Code	List Price*	Port Code	List Price*
Inch	Code 61	SAE-12	SAE-6	Q		Q/S	
Metric	Code 61	.75 BSPP	.25 BSPP	Q/M		Q/T	

*For part number and price for body only contact your local SUN distributor.

These SUN valve assemblies are for use in bleeding hot oil from the low pressure side of a hydrostatic transmission circuit. The hot oil can be cooled, filtered, or used as a source of oil for flushing other pump and motor cases. The hot oil is removed from the loop when the SUN RPEC cartridge is set below the hydrostatic charge pressure relief valve.

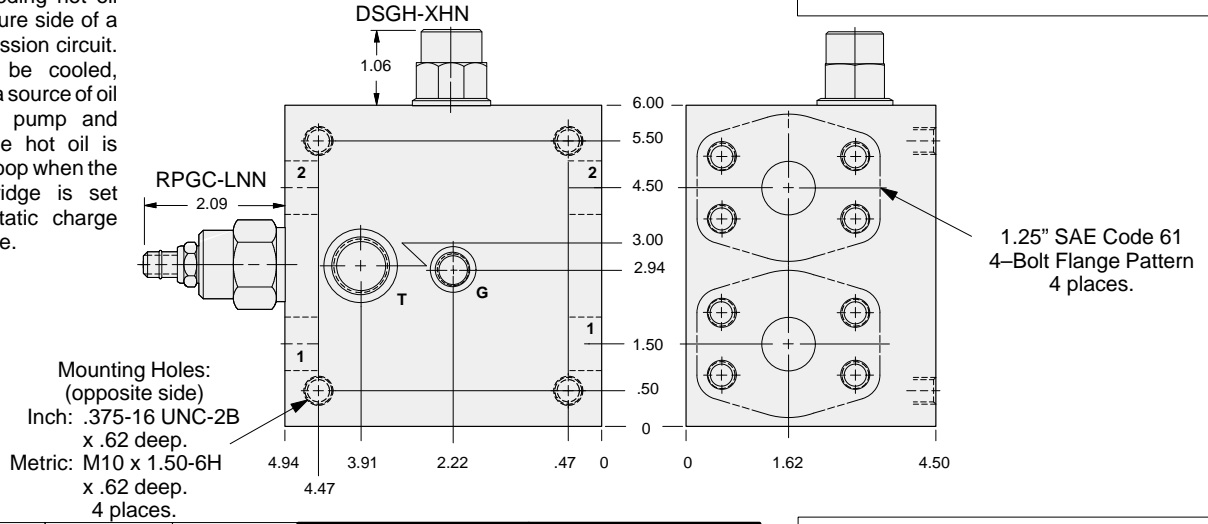
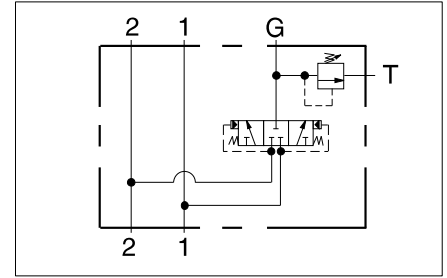

Mounting Hole Dimensions	Ports 1 & 2	Port T	Gage Port	ALUMINUM		DUCTILE IRON	
				Port Code	List Price*	Port Code	List Price*
Inch	Code 62	SAE-12	SAE-6	5		5/S	
Metric	Code 62	.75 BSPP	.25 BSPP	5/M		5/T	

*For part number and price for body only contact your local SUN distributor.

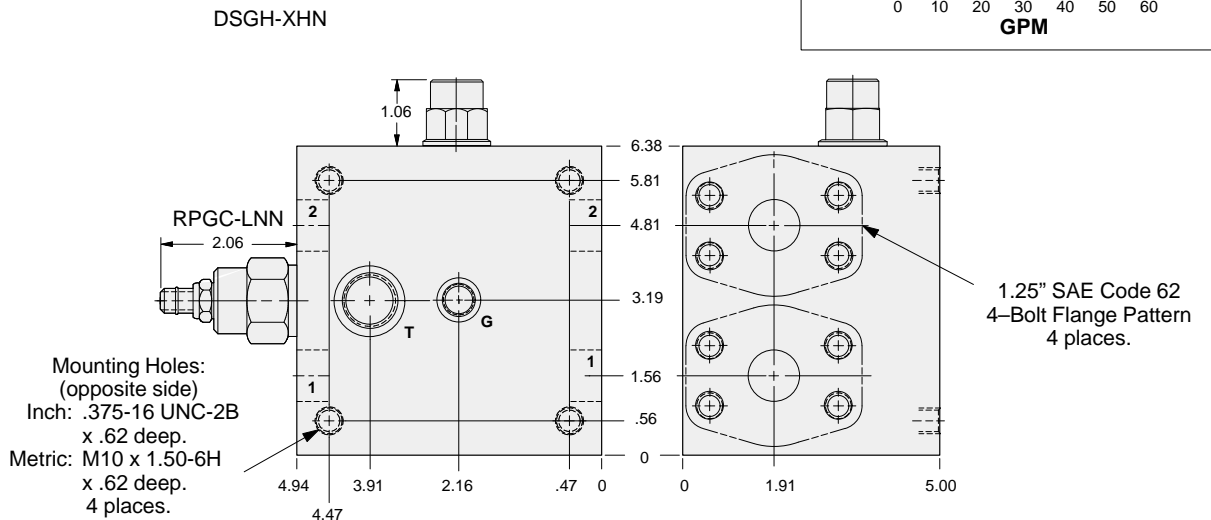
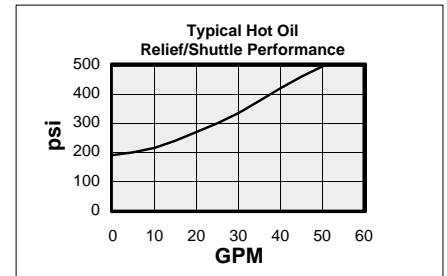

OPTIONS	XRHC - LNN - A*	
	CARTRIDGE RPGC Pg 1.06 For Viton Seals Change LNN to LNV.	PORTS See Chart above



13





HOT OIL SHUTTLE AND RELIEF ASSEMBLY INLINE BODY



- Aluminum rated to 3000 psi and Ductile Iron rated to 5000 psi.
- Hot oil pressure can be confirmed and/or set with transmission in neutral.

These SUN valve assemblies are for use in bleeding hot oil from the low pressure side of a hydrostatic transmission circuit. The hot oil can be cooled, filtered, or used as a source of oil for flushing other pump and motor cases. The hot oil is removed from the loop when the SUN RPEC cartridge is set below the hydrostatic charge pressure relief valve.

Mounting Hole Dimensions	Ports 1 & 2	Port T	Gage Port	ALUMINUM		DUCTILE IRON	
				Port Code	List Price*	Port Code	List Price*
Inch	SAE-20	SAE-16	SAE-6	M		M/S	
Metric	1.25 BSPB	1.00 BSBP	.25 BSBP	X		X/S	

*For part number and price for body only contact your local SUN distributor.

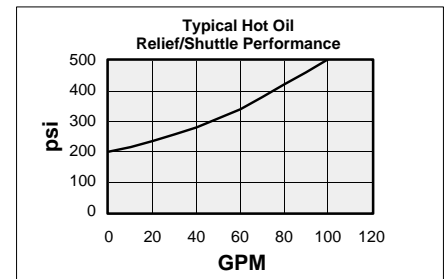
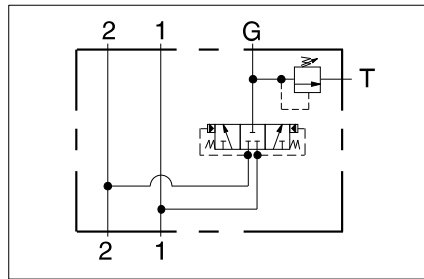

Mounting Holes:
(opposite side)
Inch: .375-16 UNC-2B
x .62 deep.
Metric: M10 x 1.50-6H
x .62 deep.
2 places.

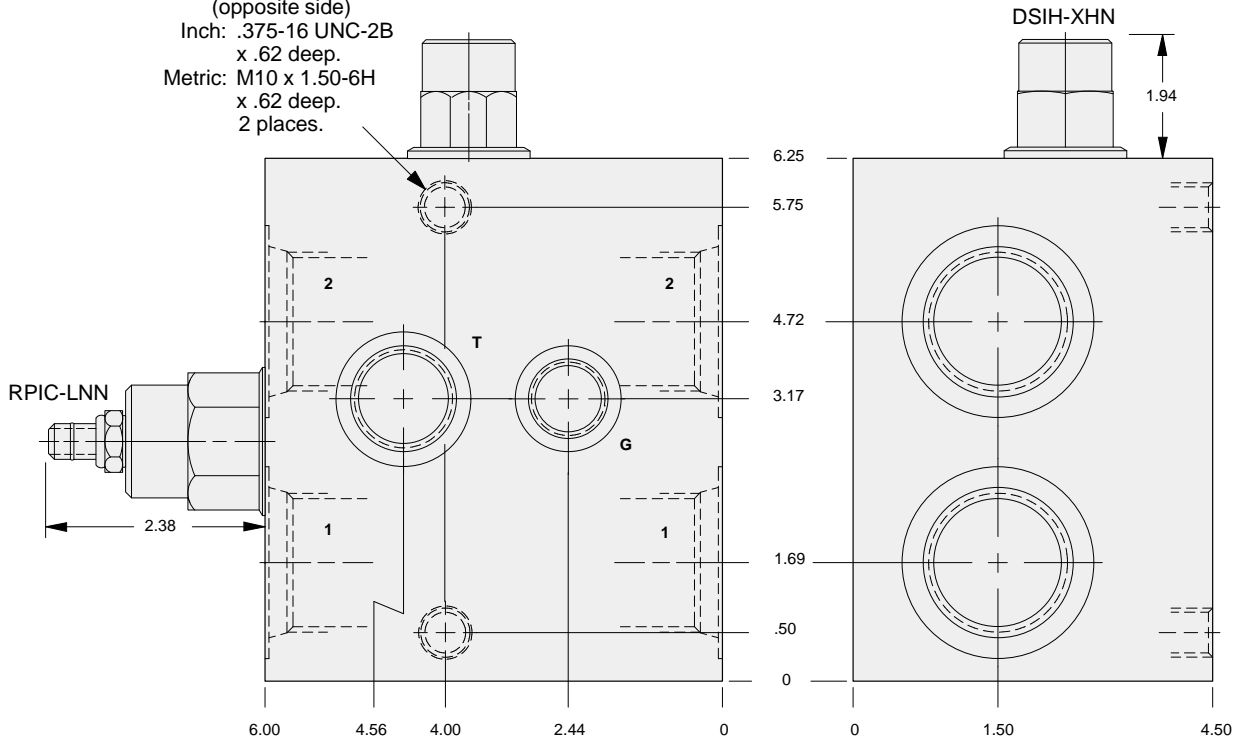

OPTIONS	XRJC - LNN - A*		
	CARTRIDGE RPIC Pg 1.07 For Viton Seals Change LNN to LNV.	Customer Specified Setting Stamped on Hex	PORTS See Chart above



HOT OIL SHUTTLE AND RELIEF ASSEMBLY 1.50" SAE FLANGE PORT BODY



- Aluminum rated to 3000 psi and Ductile Iron rated to 5000 psi.
- Hot oil pressure can be confirmed and/or set with transmission in neutral.

Mounting Hole Dimensions	Ports 1 & 2	Port T	Gage Port	ALUMINUM		DUCTILE IRON	
				Port Code	List Price*	Port Code	List Price*
Inch	Code 61	SAE-16	SAE-6	R		R/S	
Metric	Code 61	1.00 BSPP	.25 BSPP	R/M		R/T	

*For part number and price for body only contact your local SUN distributor.

These SUN valve assemblies are for use in bleeding hot oil from the low pressure side of a hydrostatic transmission circuit. The hot oil can be cooled, filtered, or used as a source of oil for flushing other pump and motor cases. The hot oil is removed from the loop when the SUN RPEC cartridge is set below the hydrostatic charge pressure relief valve.

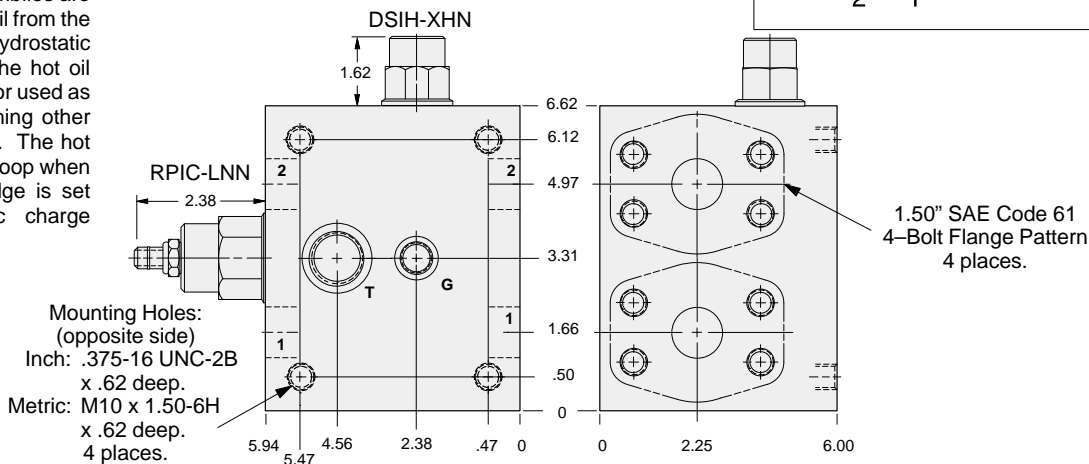
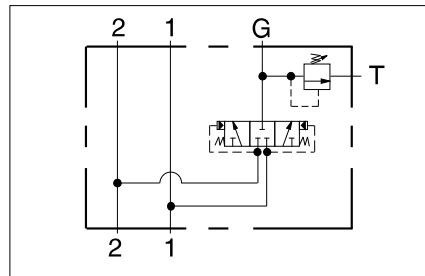

Mounting Hole Dimensions	Ports 1 & 2	Port T	Gage Port	ALUMINUM		DUCTILE IRON	
				Port Code	List Price*	Port Code	List Price*
Inch	Code 62	SAE-16	SAE-6	6		6/S	
Metric	Code 62	1.00 BSPP	.25 BSPP	6/M		6/T	

*For part number and price for body only contact your local SUN distributor.

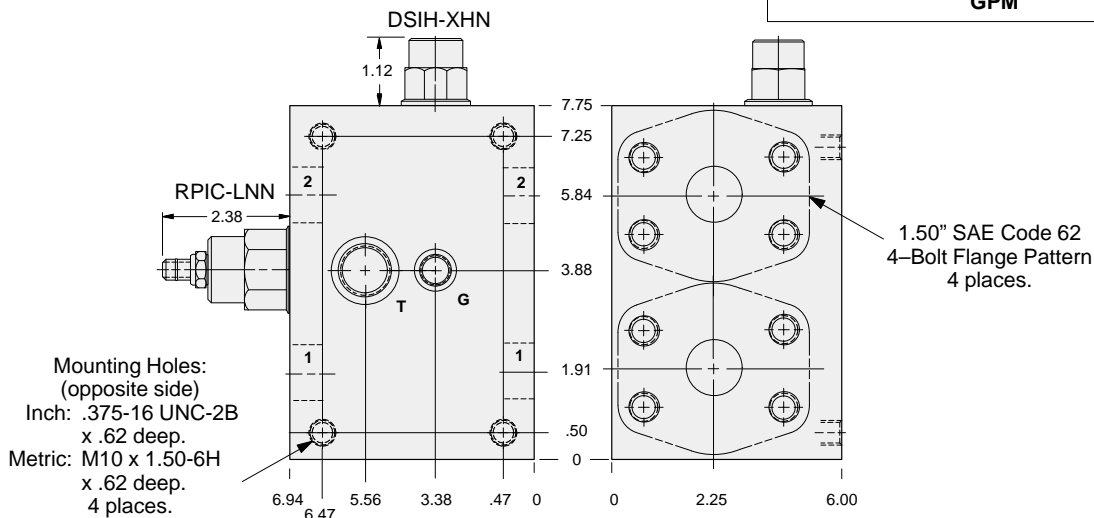
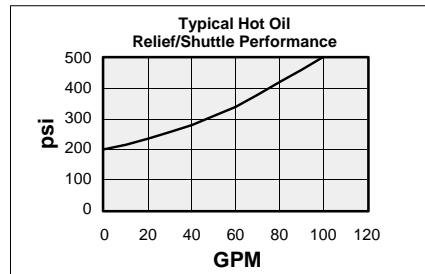

OPTIONS

XRJC - LNN - A*

CARTRIDGE

RPIC Pg 1.07
For Viton Seals Change LNN to LNV.

Customer Specified Setting
Stamped on Hex

PORTS

See Chart above



HOT OIL SHUTTLE AND RELIEF ASSEMBLY 2.00" SAE FLANGE PORT BODY



- Aluminum rated to 3000 psi and Ductile Iron rated to 5000 psi.
- Hot oil pressure can be confirmed and/or set with transmission in neutral.

Mounting Hole Dimensions	Ports 1 & 2	Port T	Gage Port	ALUMINUM		DUCTILE IRON	
				Port Code	List Price*	Port Code	List Price*
Inch	Code 61	SAE-16	SAE-6	S		S/S	
Metric	Code 61	1.00 BSPP	.25 BSPP	S/M		S/T	

*For part number and price for body only contact your local SUN distributor.

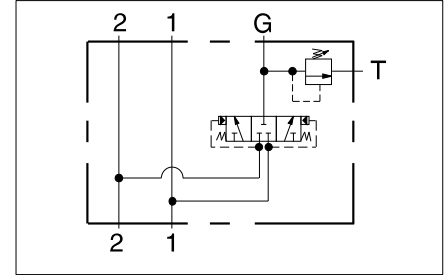

These SUN valve assemblies are for use in bleeding hot oil from the low pressure side of a hydrostatic transmission circuit. The hot oil can be cooled, filtered, or used as a source of oil for flushing other pump and motor cases. The hot oil is removed from the loop when the SUN RPIC cartridge is set below the hydrostatic charge pressure relief valve.

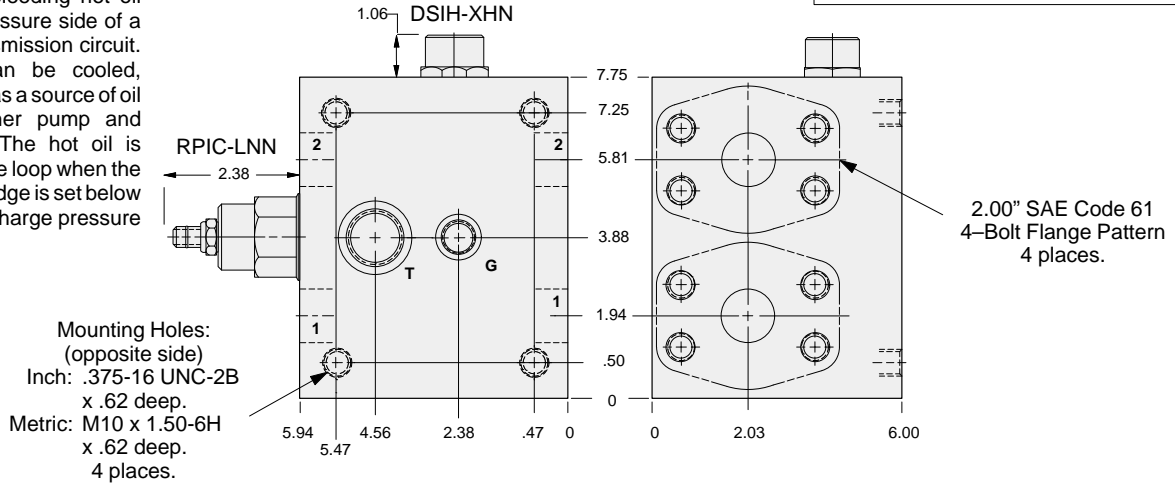

Mounting Hole Dimensions	Ports 1 & 2	Port T	Gage Port	ALUMINUM		DUCTILE IRON	
				Port Code	List Price*	Port Code	List Price*
Inch	Code 62	SAE-16	SAE-6	8		8/S	
Metric	Code 62	1.00 BSPP	.25 BSPP	8/M		8/T	

*For part number and price for body only contact your local SUN distributor.

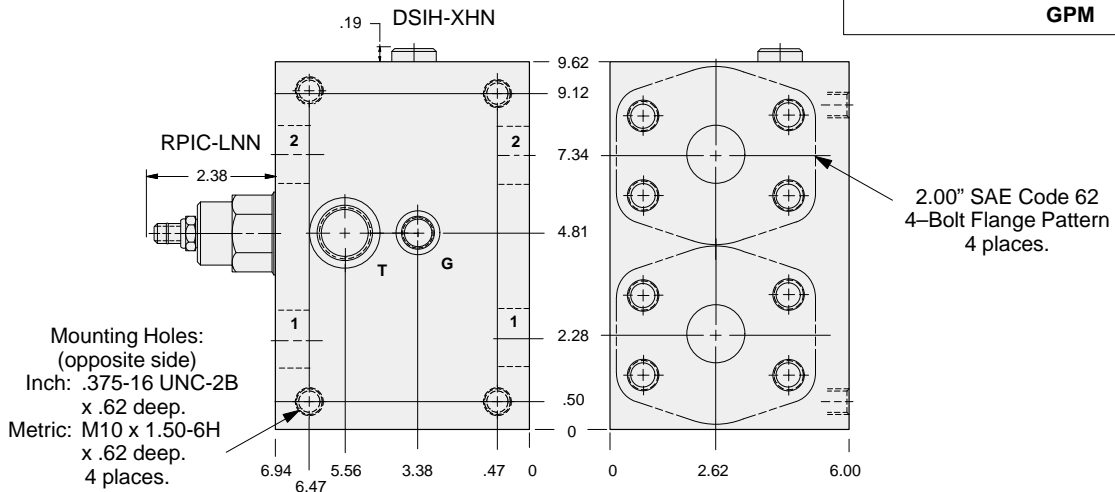
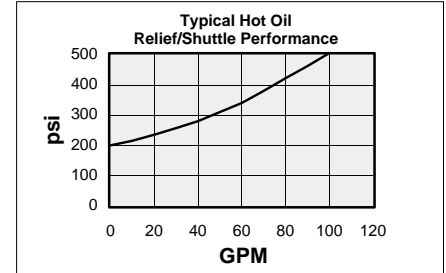

OPTIONS	XRJC - LNN - A*	
CARTRIDGE	RPIC Pg 1.07 For Viton Seals Change LNN to LNV.	PORTS See Chart above
	Customer Specified Setting Stamped on Hex	



FLOW DIVIDER/COMBINER TRACTIVE DRIVE ASSEMBLY



- Aluminum rated to 3000 psi and Ductile Iron rated to 5000 psi.
- Replaceable slip orifices.

Orifice Options

Orifice Code	Slip @ 350 psi	Slip @ 3000 psi
	Flow (GPM)	Flow (GPM)
A	0	0
L	0.7	1.9
P	1.7	4.7
R	2.8	7.7

Other slip ranges are available, and are detailed on SUN drawing #280-038.
Slip at 350 psi is additive to basic capacity.

Port Options

Ports 2, 3 & 4	ALUMINUM		DUCTILE IRON	
	Port Code	List Price*	Port Code	List Price*
.25 NPTF	A		A/S	
.375 NPTF	B		B/S	
.50 NPTF	C		C/S	
SAE-6	I		I/S	
SAE-8	J		J/S	
SAE-10	K		K/S	
.25 BSPP	T		T/S	
.375 BSPP	U		U/S	
.50 BSPP	V		V/S	

*For part number and price for body only contact your local SUN distributor.

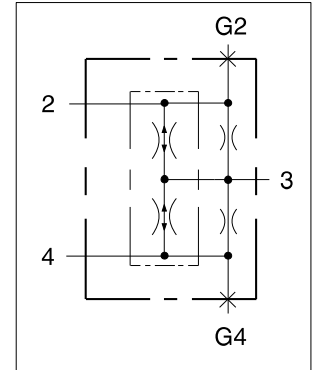

13

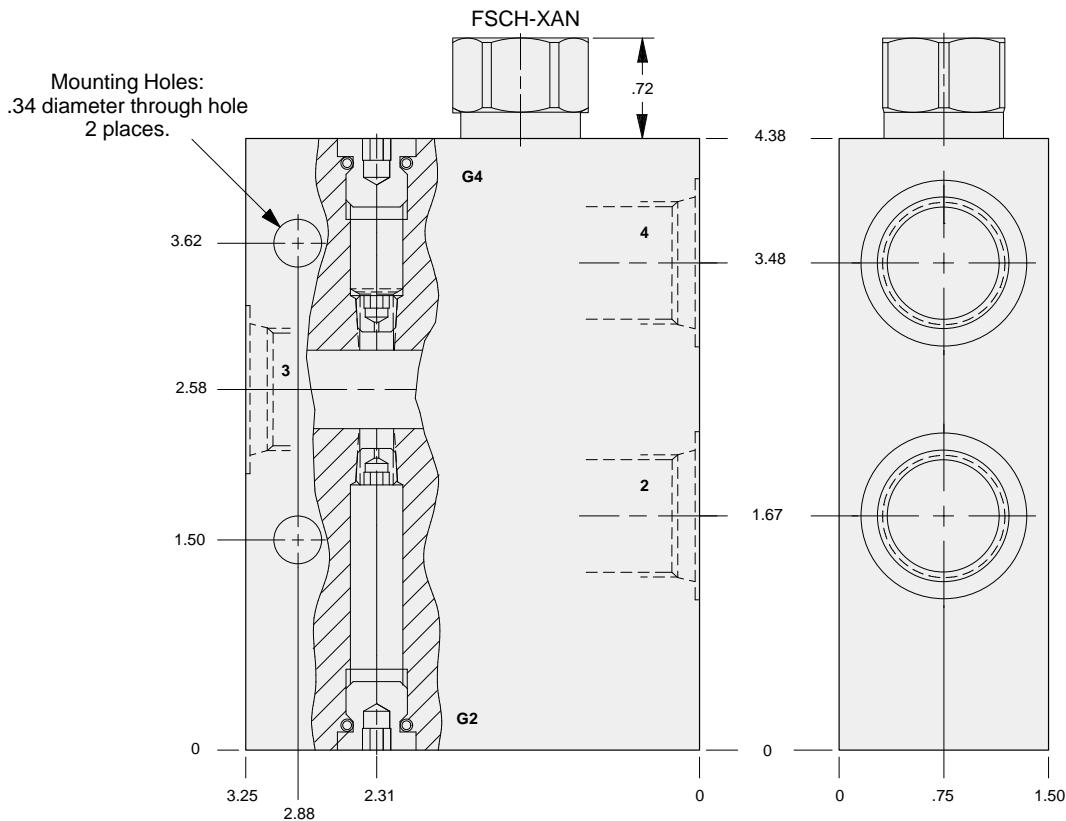

Removable orifice accessible through ports G2 and G4.

OPTIONS	YGCB - XAN - * *		
CARTRIDGE FSCH Pg 7.14 For Viton Seals Change XAN to XAV.	Customer Specified Setting Stamped on Hex	ORIFICE See Chart above	PORTS See Chart above



FLOW DIVIDER/COMBINER TRACTIVE DRIVE ASSEMBLY



- Aluminum rated to 3000 psi and Ductile Iron rated to 5000 psi.
- Replaceable slip orifices.

Orifice Options

Orifice Code	Slip @ 350 psi	Slip @ 3000 psi
	Flow (GPM)	Flow (GPM)
A	0	0
N	1.2	3.1
S	3.4	9.2
U	6.0	16.2

Other slip ranges are available, and are detailed on SUN drawing #280-038. Slip at 350 psi is additive to basic capacity.

Port Options

Ports 2, 3 & 4	ALUMINUM		DUCTILE IRON	
	Port Code	List Price*	Port Code	List Price*
.375 NPTF	B		B/S	
.50 NPTF	C		C/S	
.75 NPTF	D		D/S	
SAE-8	J		J/S	
SAE-10	K		K/S	
SAE-12	L		L/S	
.375 BSPP	U		U/S	
.50 BSPP	V		V/S	
.75 BSPP	W		W/S	

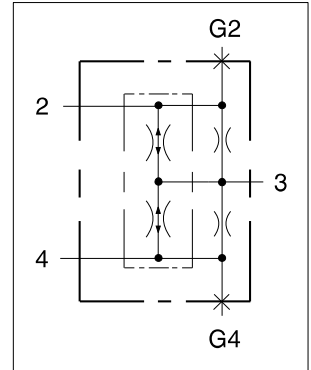

*For part number and price for body only contact your local SUN distributor.

Mounting Holes:
.34 diameter through hole
2 places.

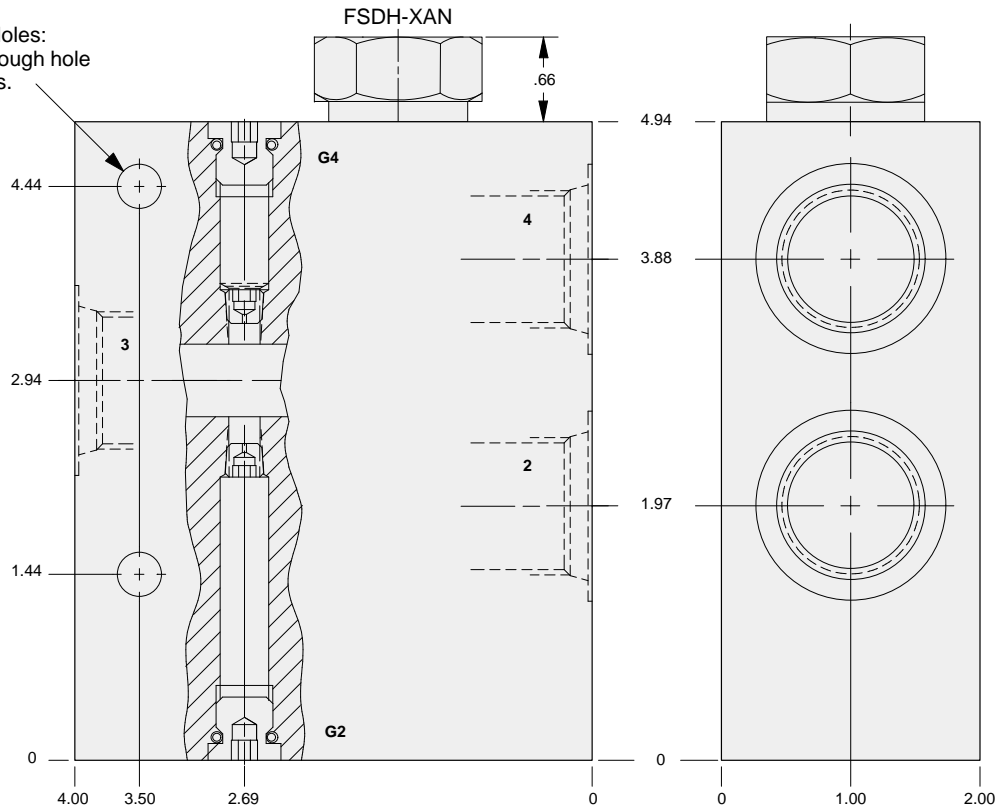

Removable orifice accessible through ports G2 and G4.

OPTIONS	YGDB - XAN - * *		
CARTRIDGE FSDH Pg 7.14 For Viton Seals Change XAN to XAV.	Customer Specified Setting Stamped on Hex	ORIFICE See Chart above	PORTS See Chart above



FLOW DIVIDER/COMBINER TRACTIVE DRIVE ASSEMBLY



- Aluminum rated to 3000 psi and Ductile Iron rated to 5000 psi.
- Replaceable slip orifices.

Orifice Options

Orifice Code	Slip @ 350 psi	Slip @ 3000 psi
	Flow (GPM)	Flow (GPM)
A	0	0
Q	2.3	6.3
U	6.0	16.2
W	9.2	25.3

Other slip ranges are available, and are detailed on SUN drawing #280-038. Slip at 350 psi is additive to basic capacity.

Port Options

Ports 2, 3 & 4	ALUMINUM		DUCTILE IRON	
	Port Code	List Price*	Port Code	List Price*
.75 NPTF	D		D/S	
1.00 NPTF	E		E/S	
SAE-12	L		L/S	
SAE-16	M		M/S	
.75 BSPP	W		W/S	
1.00 BSPP	X		X/S	

*For part number and price for body only contact your local SUN distributor.

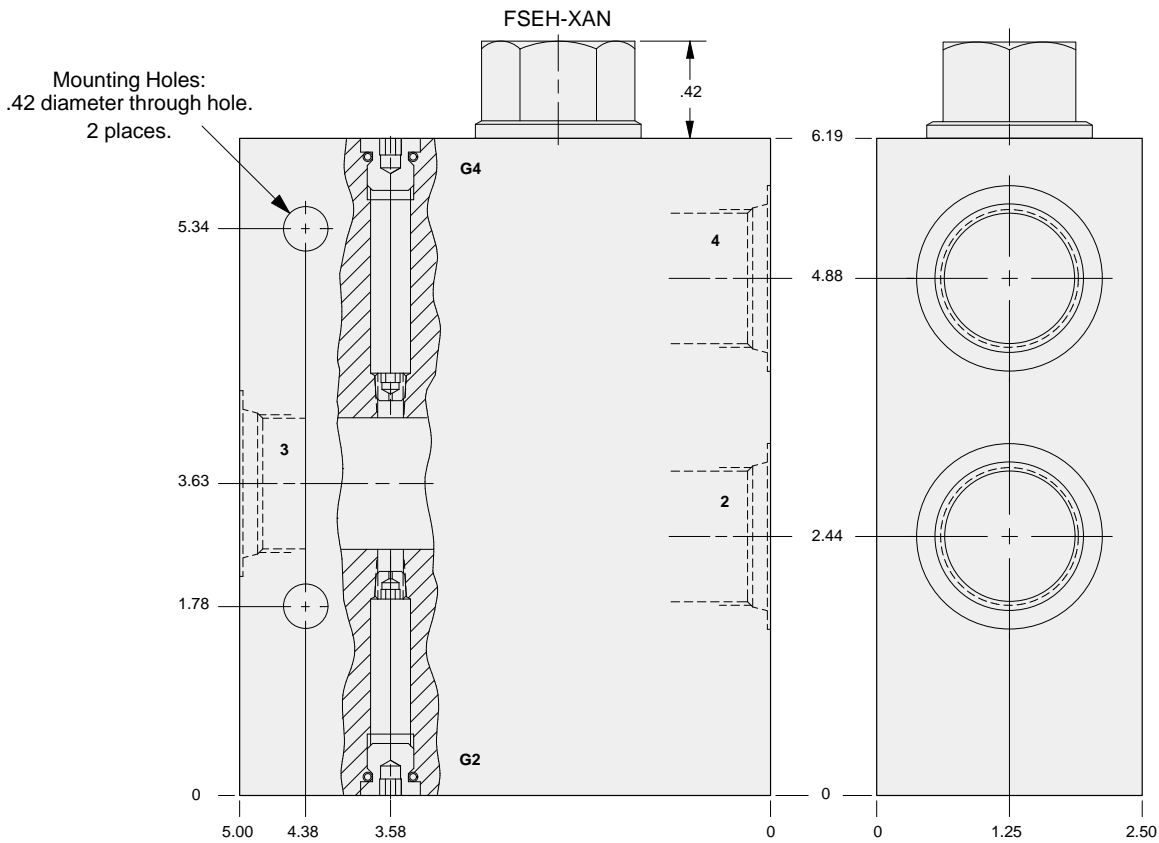
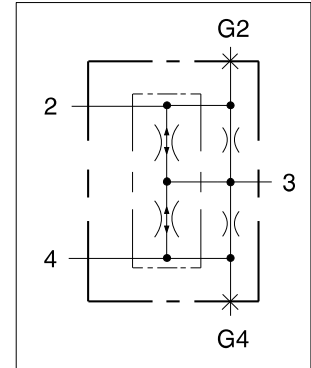

Removable orifice accessible through ports G2 and G4.

OPTIONS

YGEB - XAN - * *

CARTRIDGE

FSEH Pg 7.15
For Viton Seals Change
XAN to XAV.

Customer Specified Setting
Stamped on Hex

ORIFICE

See Chart
above

PORTS

See Chart
above



FLOW DIVIDER/COMBINER TRACTIVE DRIVE ASSEMBLY



- Aluminum rated to 3000 psi and Ductile Iron rated to 5000 psi.
- Replaceable slip orifices.

Orifice Options

Orifice Code	Slip @ 350 psi	Slip @ 3000 psi
	Flow (GPM)	Flow (GPM)
A	0	0
T	4.6	12.3
X	13.5	36.7
Y	24.0	64.8

Other slip ranges are available, and are detailed on SUN drawing #280-040. Slip at 350 psi is additive to basic capacity.

Port Options

Ports 2, 3 & 4	ALUMINUM		DUCTILE IRON	
	Port Code	List Price*	Port Code	List Price*
1.00 NPTF	E		E/S	
1.25 NPTF	F		F/S	
SAE-16	M		M/S	
SAE-20	N		N/S	
1.00 BSPP	X		X/S	
1.25 BSPP	Y		Y/S	

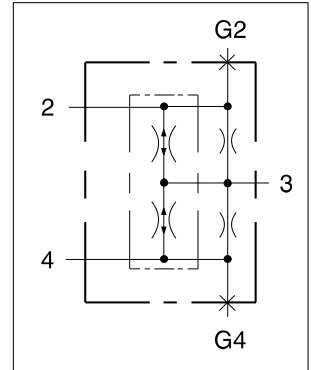

*For part number and price for body only contact your local distributor.

Mounting Holes:
.42 diameter through hole.
2 places.

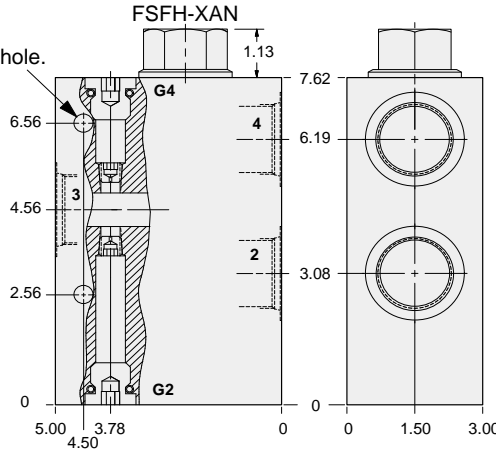

Removable orifice accessible through ports G2 and G4.

Orifice Options

Orifice Code	Slip @ 350 psi	Slip @ 3000 psi
	Flow (GPM)	Flow (GPM)
A	0	0
T	4.6	12.3
X	13.5	36.7
Y	24.0	64.8

Other slip ranges are available, and are detailed on SUN drawing #280-040. Slip at 350 psi is additive to basic capacity.

Mounting Holes:	Port 3 Code 61	Port 2 & 4 Code 61	ALUMINUM		DUCTILE IRON	
			Port Code	List Price*	Port Code	List Price*
Inch	1.25"	1.00"	Q		Q/S	
Metric	1.25"	1.00"	Q/M		Q/T	

*For part number and price for body only contact your local distributor.

1.25" SAE Code 61
4-Bolt Flange Pattern

Mounting Holes:
(opposite side)
Inch: .375-16 UNC-2B
x .62 deep.
Metric: M10 x 1.50-6H
x .62 deep.
2 places.

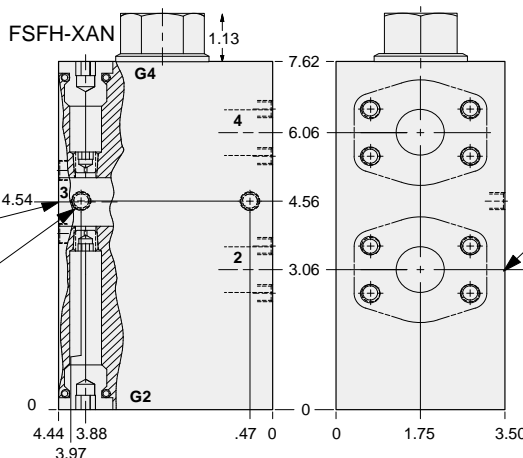

Removable orifice accessible through ports G2 and G4.

OPTIONS

YGFB - XAN - * *

CARTRIDGE

FSFH Pg 7.15
For Viton Seals Change
XAN to XAV.

ORIFICE

See Chart
above

PORTS

See Chart
above

Customer Specified Setting
Stamped on Hex

Applications

Regenerative circuits allow a cylinder to be advanced more rapidly than it could be with pump flow alone. To achieve this, oil from the rod end of a cylinder is added to the pump flow to the blind end, increasing the rate of advance.

NOTE: Regeneration circuits apply only to single rod cylinders in the extended direction.

SUN Hydraulics offers two types of regenerative valve assemblies, pressure sensitive and continuous regeneration.

Determination of the type of regenerative circuit to be used is dependent upon the system requirements. In making this determination, several areas need careful consideration.

Pressure sensitive regenerative valves will provide regenerative flow to the blind end of the cylinder until the load induced pressure reaches the setting of the counterbalance valve, at which time rod end oil is automatically diverted to tank. The circuit then becomes non-regenerative and full system pressure is applied to the full blind area, allowing it to develop maximum force.

Continuous (or full time) regenerative valves will provide regenerative flow to the blind end of the cylinder during the complete extension cycle.

Hydraulic cylinders are manufactured with an almost unlimited combination of cylinder-to-rod ratios. These ratios can have a dramatic effect on the speed of extension and retraction of the cylinders.

A 2:1 cylinder (i.e. The blind end piston area is twice the rod end area.) will extend and retract at the same speed if regeneration is used. Without regeneration, the extend speed would be 50% of the retract speed.

Cylinders with large rod diameters typically offer small amounts of oil for use in cylinder extension in regenerative circuits. Rod extension speed therefore may not be increased substantially. In contrast, when retracting a large rod diameter cylinder in a regenerative circuit, the speed may be so great, due the small volume of oil required, that the system may become unstable and generate shock. Conversely, cylinders with small rod diameters may produce shock on rod extension, and retract slowly.

When applying pressure sensitive regenerative valve assemblies, several factors must be considered:

- The pressure required to move a cylinder.
- Rod-to-diameter ratio.
- Pressure adjustment methods required to control the setting of the SUN counterbalance valve.

Losses due to high flows and seal friction may prevent a circuit from staying in regeneration. *Be conservative in system design.*

NOTE: In applications where the load tends to extend the cylinder, a vented pilot to open check valve or a vented counterbalance valve may be installed in the cylinder rod port to positively lock the cylinder.

Formulae to calculate flow in regenerative circuits include:

$$\text{Regenerative Flow (flow out the rod end)} = \frac{Db^2 - Dr^2}{Dr^2} \times \text{Pump Flow}$$

$$\text{Combined Flow (pump flow plus regenerative flow)} = \frac{Db^2}{Dr^2} \times \text{Pump Flow}$$

$$\text{Retraction Flow (flow out of the blind end during retraction)} = \frac{Db^2}{Db^2 - Dr^2} \times \text{Pump Flow}$$

Db = Bore Diameter

Dr = Rod Diameter

Design Concepts and Features

SUN's pressure sensitive regenerative valve assembly incorporates a pressure adjustable counterbalance valve that provides a smooth transition when the work is engaged and pressure in the blind end rises to approximately 25% of the set point of the counterbalance valve, at which time the regenerative flow decreases smoothly until rod end flow is fully diverted to tank. Full pump pressure is then applied to the blind end area developing maximum force.

SUN's full time regenerative valve assembly utilizes a standard check valve in place of the counterbalance valve. This allows flow from the rod end to be supplied to the blind end continuously during the complete extension cycle.

SUN's regenerative valve assemblies are available in various flow rates and packaged as inline, ISO sandwich assemblies, and subplate versions.



REGENERATION ASSEMBLY PRESSURE SENSITIVE



Refer to page 13.42 for further technical information.

- Aluminum rated to 3000 psi and Ductile Iron rated to 5000 psi.

YDCC: 15 GPM maximum regenerative flow. Regeneration diminishes progressively above setting of CBCA.

Ports CH CR & VR	ALUMINUM		DUCTILE IRON	
	Port Code	List Price*	Port Code	List Price*
.50 NPTF	C		C/S	
SAE-10	K		K/S	
.50 BSPP	V		V/S	

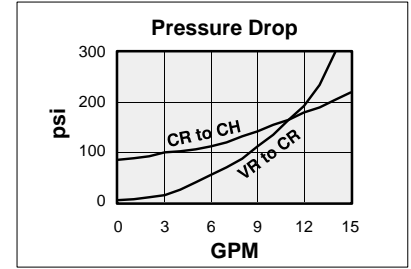
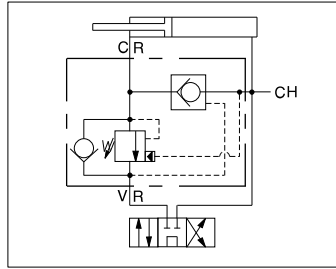

NOTE: Refer to page 13.42 if load causes cylinder to extend.
*For part number and price for body only contact your local SUN distributor.

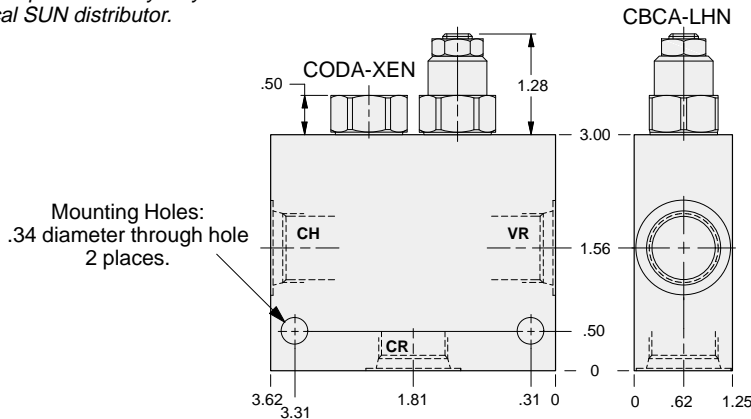

YDCD: 10 GPM maximum regenerative flow, with load holding check valve. Regeneration diminishes progressively above setting of CBCA.

Ports CH CR & VR	ALUMINUM		DUCTILE IRON	
	Port Code	List Price*	Port Code	List Price*
.50 NPTF	C		C/S	
SAE-10	K		K/S	
.50 BSPP	V		V/S	

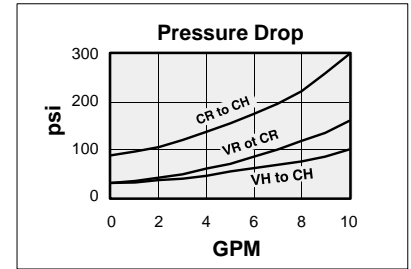
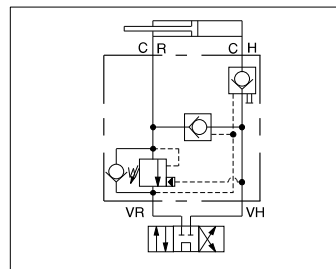

NOTE: Refer to page 13.42 if load causes cylinder to extend.
*For part number and price for body only contact your local SUN distributor.

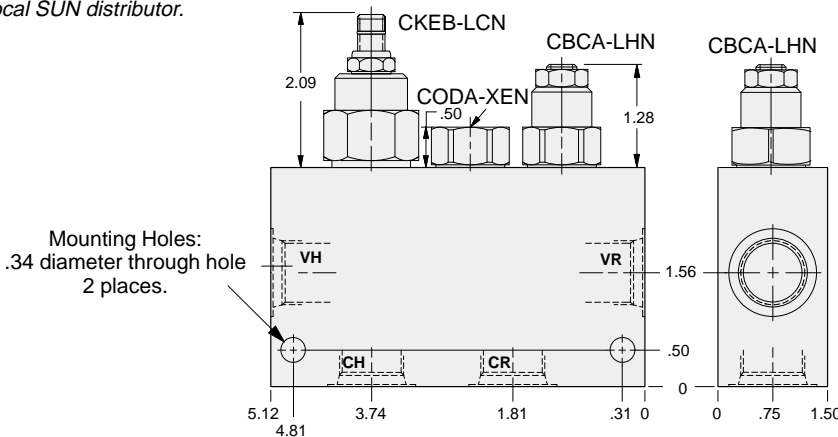

OPTIONS		YDC* - LHN - A*		PORTS
C	Less CKEB Load Holding Check	For Viton Seals Change LHN to LHV.		See Chart above
D	Includes CKEB Load Holding Check See Pg 4.16	For Viton Seals Change LHN to LHV.	Customer Specified Setting Stamped on Hex	



REGENERATION ASSEMBLY PRESSURE SENSITIVE



Refer to page 13.42 for further technical information.

- Aluminum rated to 3000 psi and Ductile Iron rated to 5000 psi.

YDEC: 30 GPM maximum regeneration flow. Regeneration diminishes progressively above setting of CBEA.

Ports CH CR & VR	ALUMINUM		DUCTILE IRON	
	Port Code	List Price*	Port Code	List Price*
.75 NPTF	D		D/S	
SAE-12	L		L/S	
.75 BSPP	W		W/S	

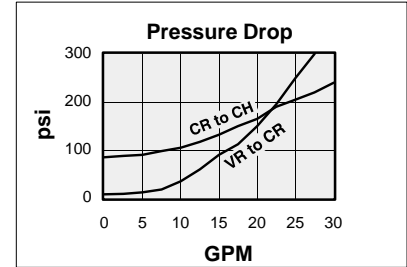
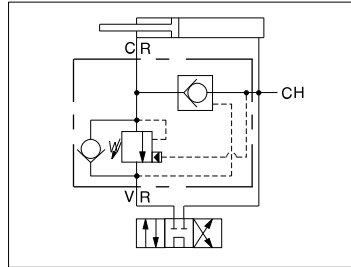

NOTE: Refer to page 13.42 if load causes cylinder to extend.
*For part number and price for body only contact your local SUN distributor.

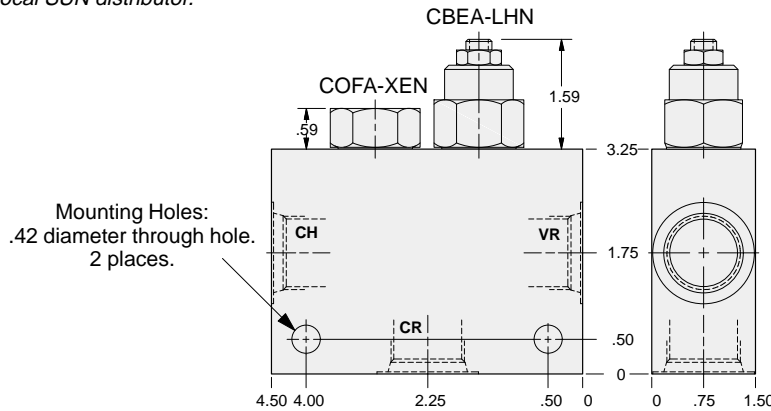

YDED: 20 GPM maximum total flow, with load holding check valve. Regeneration diminishes progressively above setting of CBEA.

Ports CH CR & VR	ALUMINUM		DUCTILE IRON	
	Port Code	List Price*	Port Code	List Price*
.75 NPTF	D		D/S	
SAE-12	L		L/S	
.75 BSPP	W		W/S	

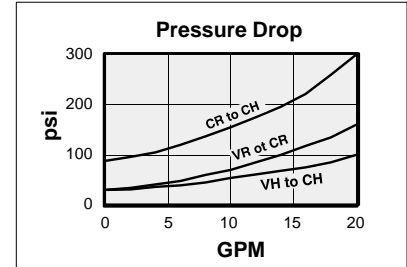
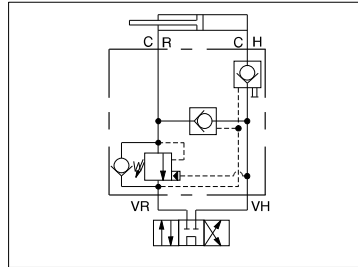

NOTE: Refer to page 13.42 if load causes cylinder to extend.
*For part number and price for body only contact your local SUN distributor.

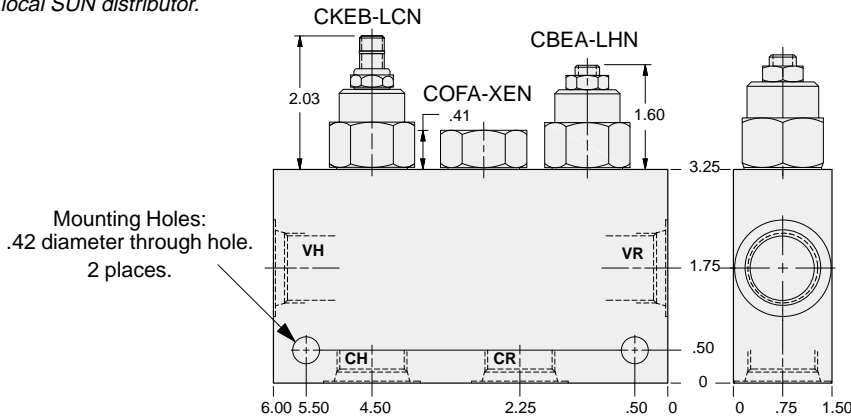

OPTIONS

YDE* - LHN - A*

FUNCTION

- C** Less CKEB Load Holding Check
- D** Includes CKEB Load Holding Check See Pg 4.16

For Viton Seals Change LHN to LHV.
For Viton Seals Change LHN to LHV.

PORTS

See Chart above

Customer Specified Setting Stamped on Hex



REGENERATION ASSEMBLY PRESSURE SENSITIVE



Refer to page 13.42 for further technical information.

- Aluminum rated to 3000 psi and Ductile Iron rated to 5000 psi.

YDGC: 60 GPM maximum regeneration flow. Regeneration diminishes progressively above setting of CBGA .

Mounting Hole Dimensions	Ports CR, CH & VR	ALUMINUM		DUCTILE IRON	
		Port Code	List Price*	Port Code	List Price*
Inch	.75 NPTF	D		D/S	
Inch	1.00 NPTF	E		E/S	
Inch	1.25 NPTF	F		F/S	
Inch	SAE-12	L		L/S	
Inch	SAE-16	M		M/S	
Inch	SAE-20	N		N/S	
Metric	.75 BSPP	W		W/S	
Metric	1.00 BSPP	X		X/S	
Metric	1.25 BSPP	Y		Y/S	
Inch	1.00" SAE Code 61	P		P/S	
Metric		P/M		P/T	

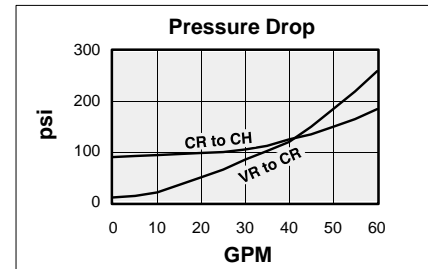
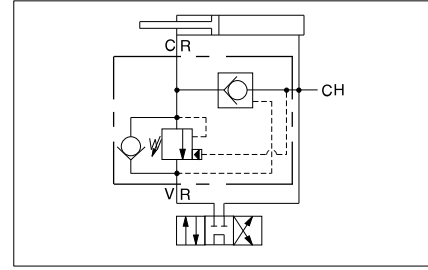

NOTE: Refer to page 13.42 if load causes cylinder to extend.

*For part number and price for body only contact your local SUN distributor.

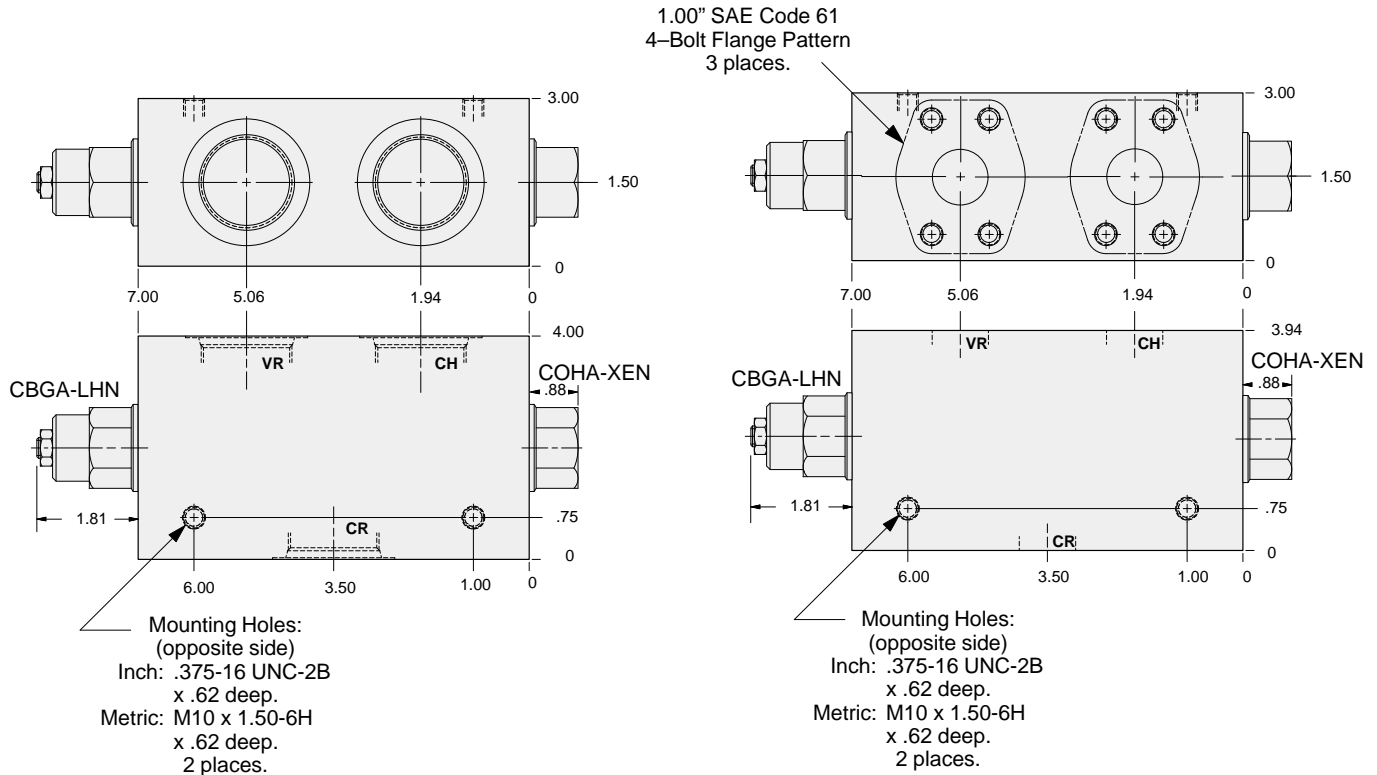

OPTIONS	YDGC - LHN - A*			
	For Viton Seals Change LHN to LHV.			PORTS See Chart above
	Customer Specified Setting Stamped on Hex			



REGENERATION ASSEMBLY PRESSURE SENSITIVE



Refer to page 13.42 for further technical information.

- Aluminum rated to 3000 psi and Ductile Iron rated to 5000 psi.

YDGD: 50 GPM maximum regeneration flow. Regeneration diminishes progressively above setting of CBGA.

Mounting Hole Dimensions	Ports CH, CR & VR	ALUMINUM		DUCTILE IRON	
		Port Code	List Price*	Port Code	List Price*
Inch	.75 NPTF	D		D/S	
Inch	1.00 NPTF	E		E/S	
Inch	1.25 NPTF	F		F/S	
Inch	SAE-12	L		L/S	
Inch	SAE-16	M		M/S	
Inch	SAE-20	N		N/S	
Metric	.75 BSPP	W		W/S	
Metric	1.00 BSPP	X		X/S	
Metric	1.25 BSPP	Y		Y/S	
Inch	1.25" SAE Code 61	Q		Q/S	
Metric		Q/M		Q/T	

NOTE: Refer to page 13.42 if load causes cylinder to extend.

*For part number and price for body only contact your local SUN distributor.

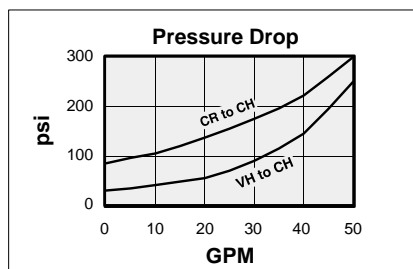
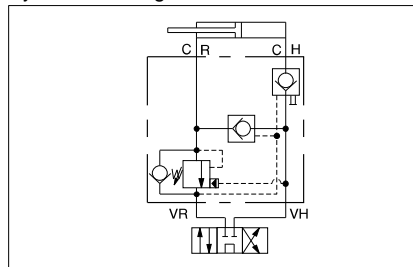

13

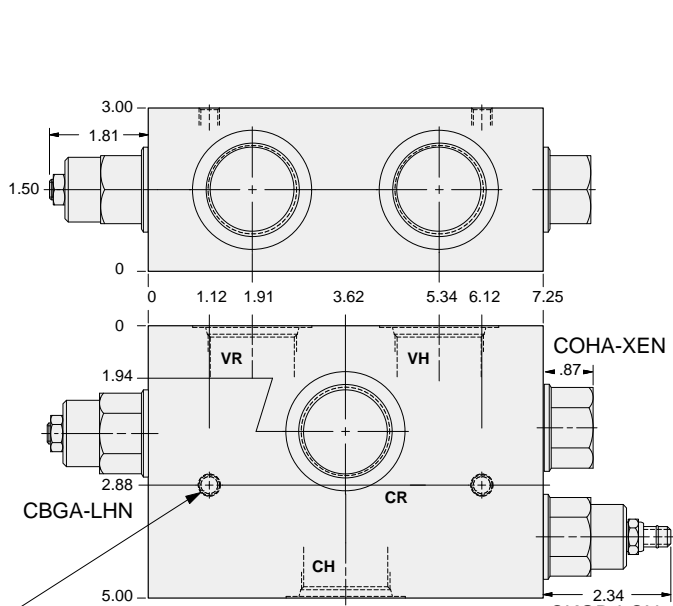

Mounting Holes:
(opposite side)
Inch: .375-16 UNC-2B
x .62 deep.
Metric: M10 x 1.50-6H
x .62 deep.
2 places.

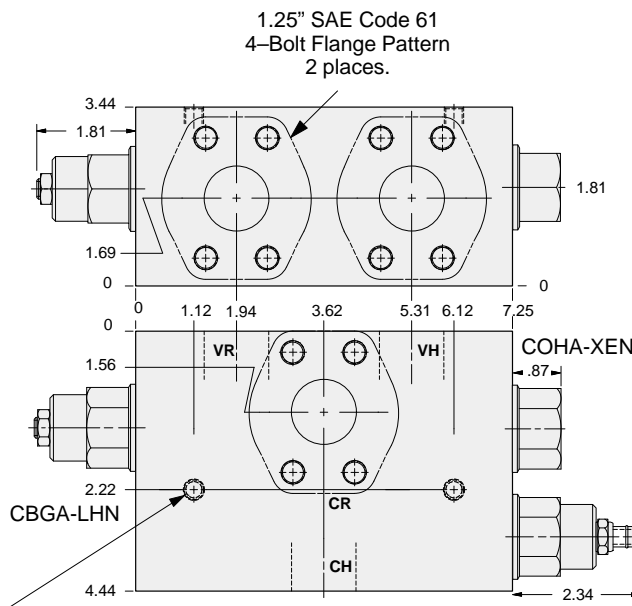

Mounting Holes:
(opposite side)
Inch: .375-16 UNC-2B
x .62 deep.
Metric: M10 x 1.50-6H
x .62 deep.
2 places.

1.25" SAE Code 61
4-Bolt Flange Pattern
2 places.

OPTIONS

YDGD - LHN - A*

For Viton Seals Change
LHN to LHV.

Customer Specified Setting
Stamped on Hex

PORTS
See Chart
above



REGENERATION ASSEMBLY PRESSURE SENSITIVE



Refer to page 13.42 for further technical information.

- Aluminum rated to 3000 psi and Ductile Iron rated to 5000 psi.

YDHC: 120 GPM maximum regeneration flow. Regeneration diminishes progressively above setting of CBGA.

Mounting Hole Dimensions	ALUMINUM		DUCTILE IRON	
	Port Code	List Price*	Port Code	List Price*
Inch	5		5/S	
Metric	5/M		5/T	

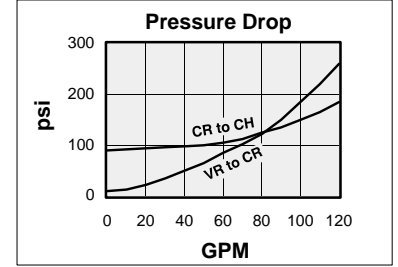
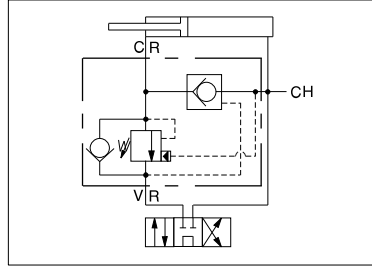

NOTE: Refer to page 13.42 if load causes cylinder to extend.

*For part number and price for body only contact your local SUN distributor.

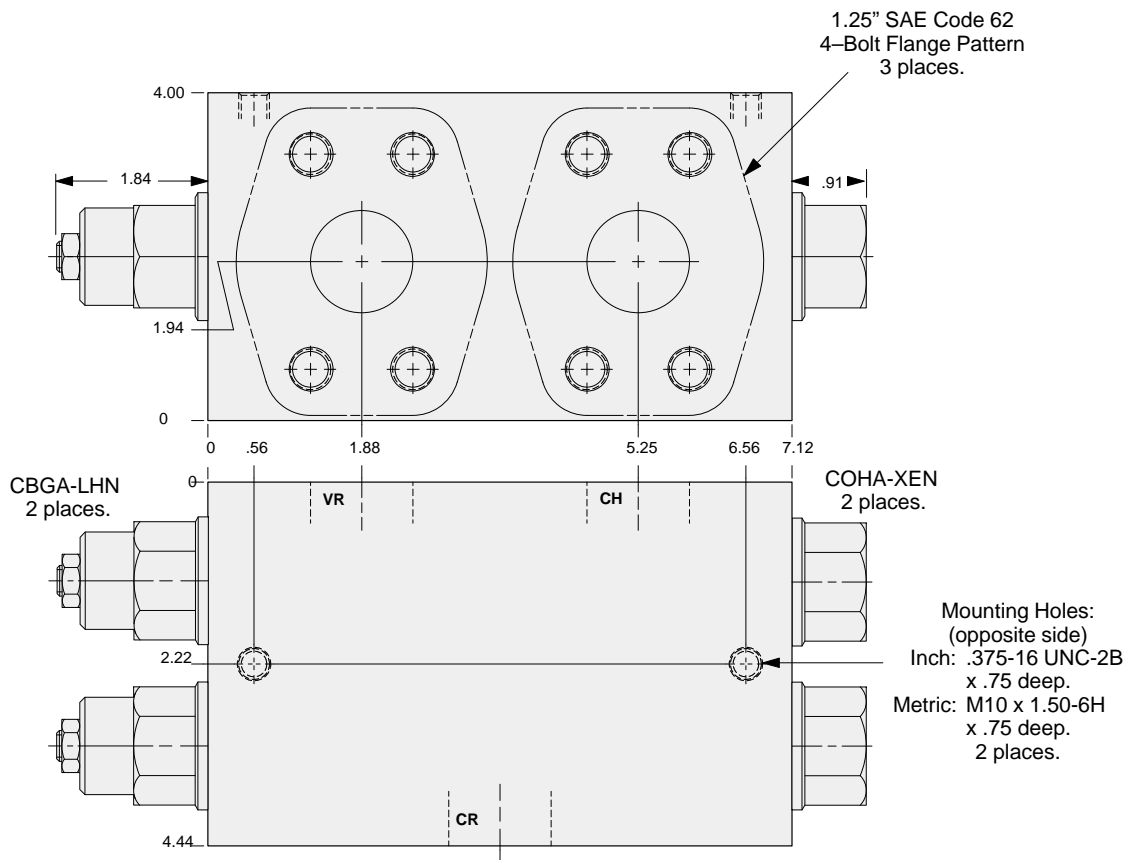

OPTIONS	YDHC - LHN - A*	PORTS
	<p>For Viton Seals Change LHN to LHV.</p> <p>Customer Specified Setting Stamped on Hex</p>	<p>See Chart above</p>



REGENERATION ASSEMBLY PRESSURE SENSITIVE



Refer to page 13.42 for further technical information.

- Aluminum rated to 3000 psi and Ductile Iron rated to 5000 psi.

YDJC: 120 GPM maximum regeneration flow. Regeneration diminishes progressively above setting of CBIA.

Ports CH CR & VR	ALUMINUM		DUCTILE IRON	
	Port Code	List Price*	Port Code	List Price*
SAE-20	N		N/S	

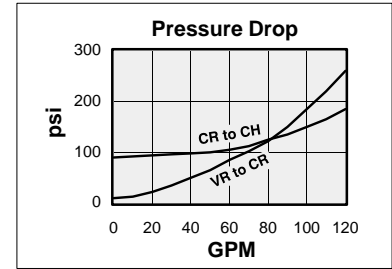
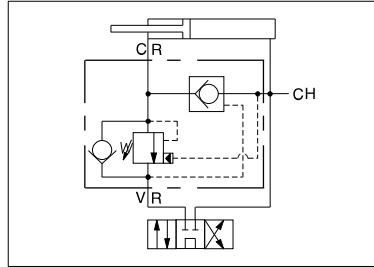

NOTE: Refer to page 13.42 if load causes cylinder to extend.
*For part number and price for body only contact your local SUN distributor.

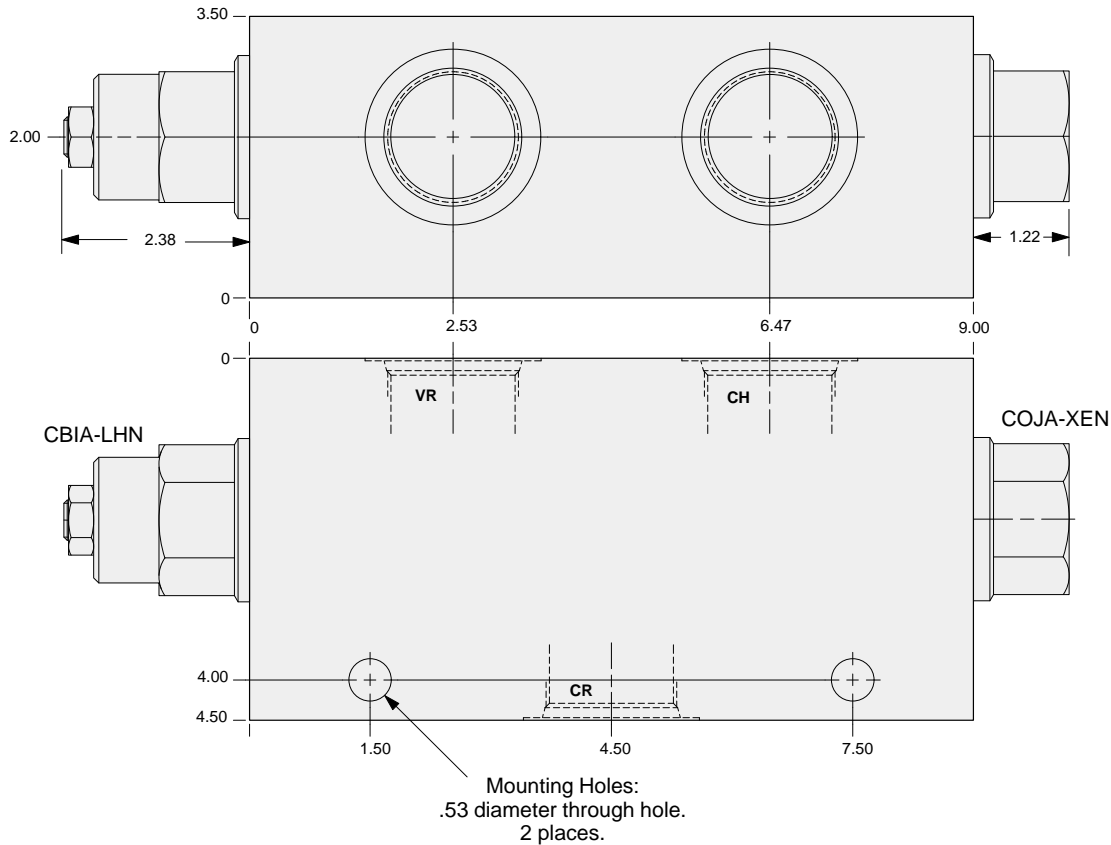

13

OPTIONS	YDJC - LHN - A*		
	For Viton Seals Change LHN to LHV.		PORTS See Chart above
	Customer Specified Setting Stamped on Hex		



REGENERATION ASSEMBLY PRESSURE SENSITIVE



Refer to page 13.42 for further technical information.

- Aluminum rated to 3000 psi and Ductile Iron rated to 5000 psi.

YDJC: 240 GPM maximum regeneration flow. Regeneration diminishes progressively above setting of CBIA.

Mounting Hole Dimensions	ALUMINUM		DUCTILE IRON	
	Port Code	List Price*	Port Code	List Price*
Inch	S		S/S	
Metric	S/M		S/T	

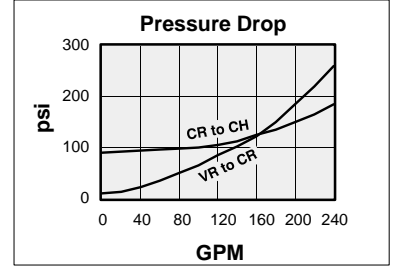
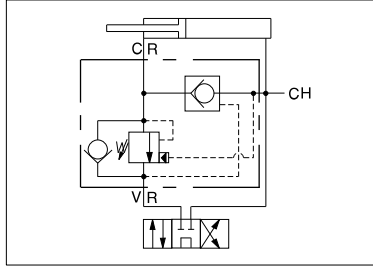

NOTE: Refer to page 13.42 if load causes cylinder to extend.
*For part number and price for body only contact your local SUN distributor.

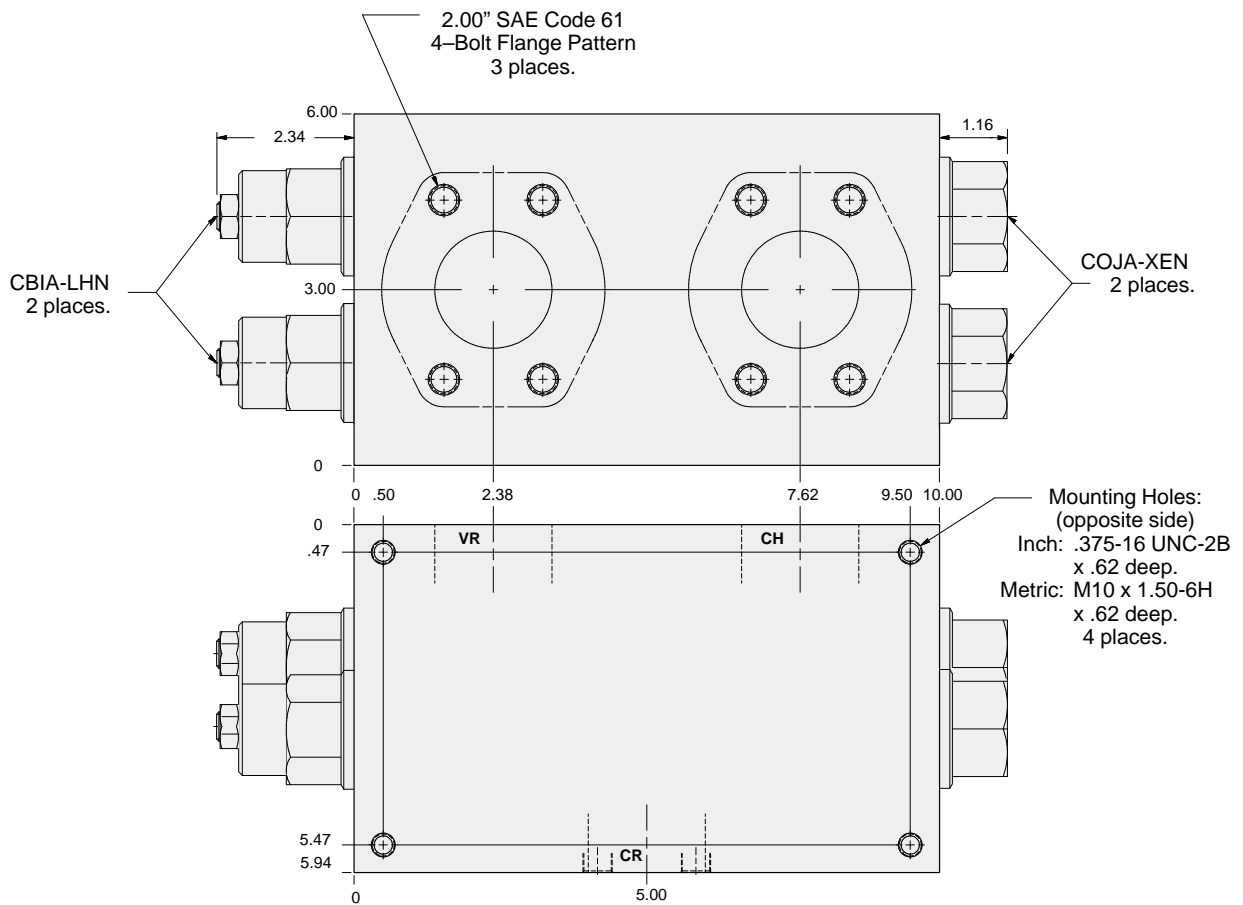

Refer to page 13.42 if load causes cylinder to extend.

OPTIONS	YDJC - LHN - A*	PORTS
	<p>For Viton Seals Change LHN to LHV.</p> <p>Customer Specified Setting Stamped on Hex</p>	<p>See Chart above</p>



ACCUMULATOR DUMP ASSEMBLY



- Aluminum rated to 3000 psi and Ductile Iron rated to 5000 psi.

Ports P, T A1 & A2	ALUMINUM		DUCTILE IRON	
	Port Code	List Price*	Port Code	List Price*
.25 NPTF	A		A/S	
.375 NPTF	B		B/S	
.50 NPTF	C		C/S	
.75 NPTF	D		D/S	
SAE-6	I		I/S	
SAE-8	J		J/S	
SAE-10	K		K/S	
SAE-12	L		L/S	
.25 BSPP	T		T/S	
.375 BSPP	U		U/S	
.50 BSPP	V		V/S	
.75 BSPP	W		W/S	

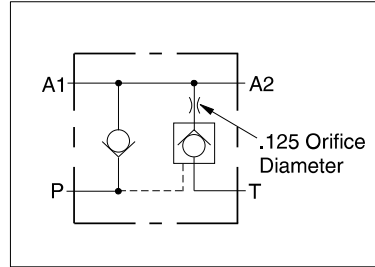

*For part number and price for body only contact your local SUN distributor.

13

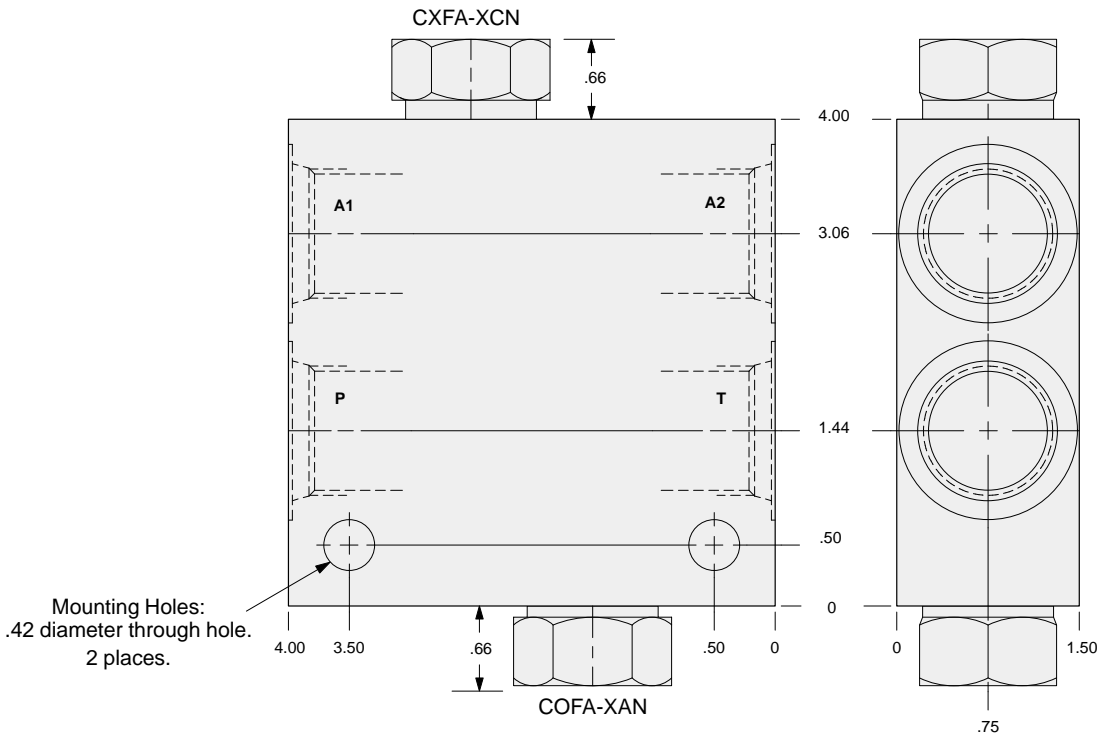

OPTIONS	YCFE - XAN - A*
	For Viton Seals Change XAN to XAV. PORTS See Chart above



ACCUMULATOR DUMP ASSEMBLY



- Aluminum rated to 3000 psi and Ductile Iron rated to 5000 psi.

Ports P, A1 & A2	Port T	ALUMINUM		DUCTILE IRON	
		Port Code	List Price*	Port Code	List Price*
.75 NPTF	.50 NPTF	D		D/S	
1.00 NPTF	.50 NPTF	E		E/S	
1.25 NPTF	.50 NPTF	F		F/S	
SAE-12	SAE-8	L		L/S	
SAE-16	SAE-8	M		M/S	
SAE-20	SAE-8	N		N/S	
.75 BSPP	.50 BSPP	W		W/S	
1.00 BSPP	.50 BSPP	X		X/S	
1.25 BSPP	.50 BSPP	Y		Y/S	

*For part number and price for body only contact your local SUN distributor.

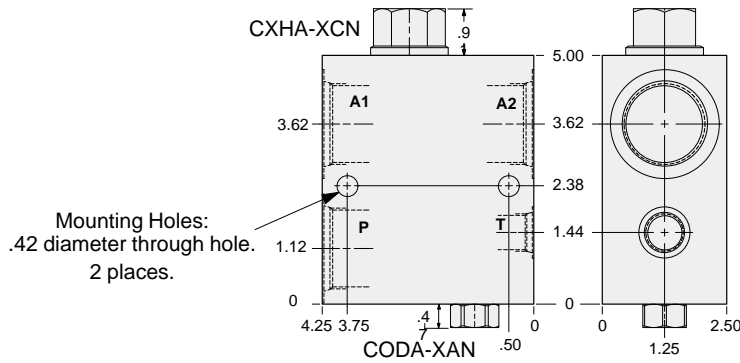
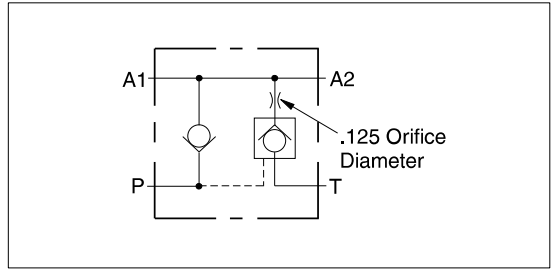

Mounting Hole Dimensions	Ports A1, A2, P Code 61	Port T	ALUMINUM		DUCTILE IRON	
			Port Code	List Price*	Port Code	List Price*
Inch	1.00"	SAE-8	P		P/S	
Metric	1.00"	.50 BSPP	P/M		P/T	
Inch	1.25"	SAE-8	Q		Q/S	
Metric	1.25"	.50 BSPP	Q/M		Q/T	

*For part number and price for body only contact your local SUN distributor.

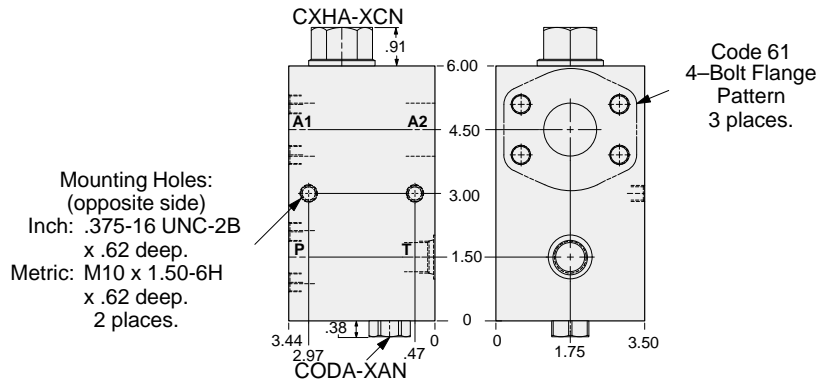
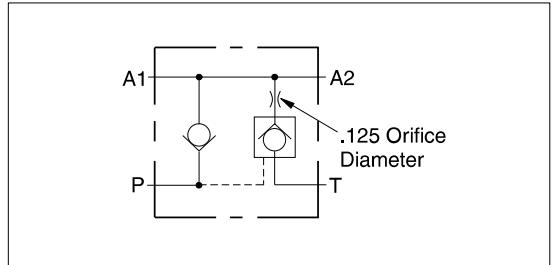

OPTIONS	YCHE - XAN - A*			
For Viton Seals Change XAN to XAV.				PORTS See Chart above



PUMP CIRCUIT CONTROL ASSEMBLY SUITABLE FOR RESERVIOR MOUNTING FOR USE WITH MULTIPLE PUMP CIRCUITS



- Aluminum rated to 3000 psi and Ductile Iron rated to 5000 psi.

YFRC: 25 GPM

Mounting Hole Dimensions	Port P, S, & T2	Port T1	Gage Port	ALUMINUM		DUCTILE IRON	
				Port Code	List Price*	Port Code	List Price*
Inch	.75 NPTF	.50 NPTF	.25 NPTF	D		D/S	
Inch	SAE-12	SAE-8	.25 NPTF	L		L/S	
Metric	.75 BSPP	.50 BSPP	.25 BSPP	W		W/S	

YFRC and YFRE valves are suitable for multiple pump circuits when connected directly to each pump in the system. They provide air-bleed and relief protection for each pump and the check valve position isolates the other pumps from the valve assembly.

*For part number and price for body only contact your local SUN distributor.

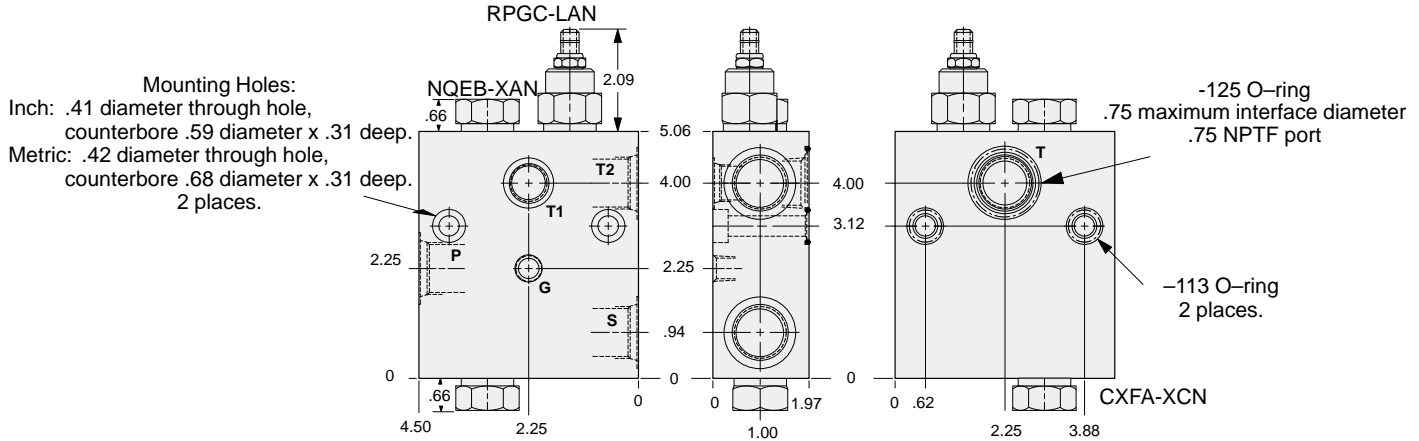

YFRE: 50 GPM

Mounting Hole Dimensions	Port P, S, & T2	Port T1	Gage Port	ALUMINUM		DUCTILE IRON	
				Port Code	List Price*	Port Code	List Price*
Inch	1.00 NPTF	.75 NPTF	.25 NPTF	E		E/S	
Inch	SAE-16	SAE-12	.25 NPTF	M		M/S	
Metric	1.00 BSPP	.75 BSPP	.25 BSPP	X		X/S	

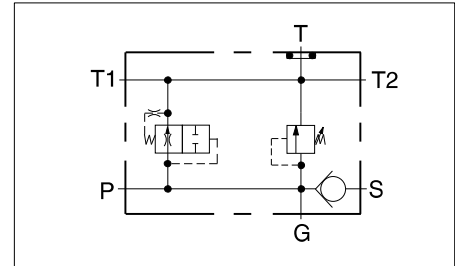

*For part number and price for body only contact your local SUN distributor.

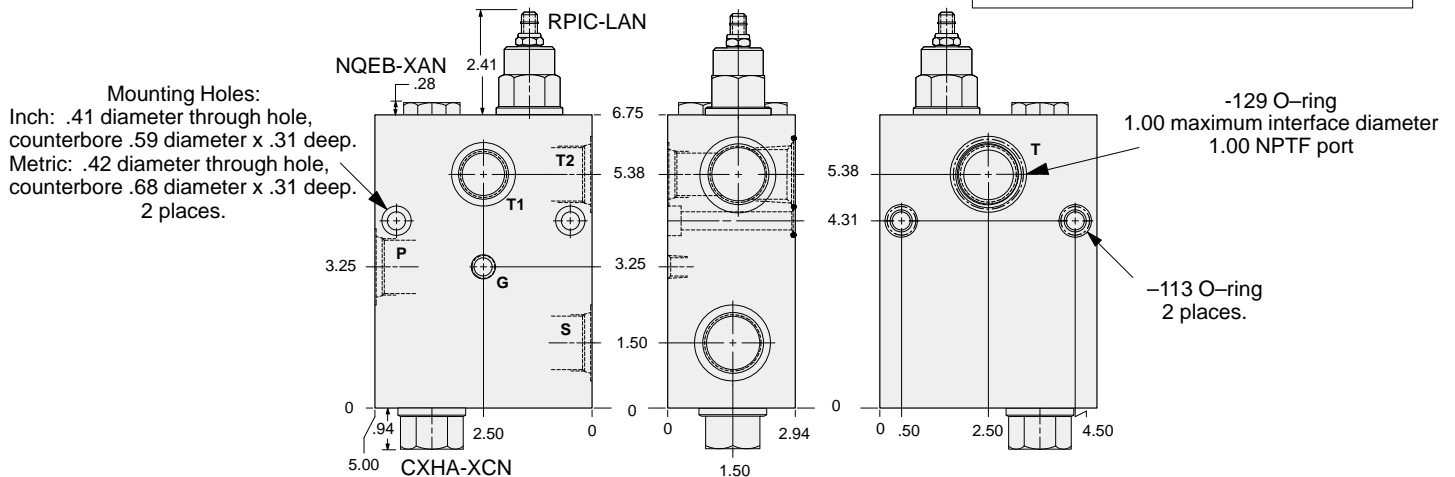

OPTIONS

YFR* - LAN - A*

FLOW CAPABILITY

- C** 25 GPM
RPGC Cartridge
- E** 50 GPM
RPIC Cartridge

PORTS

For Viton Seals Change LAN to LAV.
For Viton Seals Change LAN to LAV.

See Chart above

Customer Specified Setting
Stamped on Hex



PUMP CIRCUIT CONTROL ASSEMBLY SUITABLE FOR RESERVIOR MOUNTING FOR USE WITH SINGLE PUMP CIRCUITS



- Aluminum rated to 3000 psi and Ductile Iron rated to 5000 psi.

YFRD: 25 GPM

Mounting Hole Dimensions	Port P, S, & T2	Port T1	Gage Port	ALUMINUM		DUCTILE IRON	
				Port Code	List Price*	Port Code	List Price*
Inch	.75 NPTF	.50 NPTF	.25 NPTF	D		D/S	
Inch	SAE-12	SAE-8	.25 NPTF	L		L/S	
Metric	.75 BSPP	.50 BSPP	.25 BSPP	W		W/S	

*For part number and price for body only contact your local SUN distributor.

The SUN pump circuit manifold contains an air-bleed and start up valve, main system relief, and a check valve for use with any basic power unit. O-ring seals for one of the tank ports and bolt mounting holes are provided for direct reservoir mounting. All T ports are also threaded.

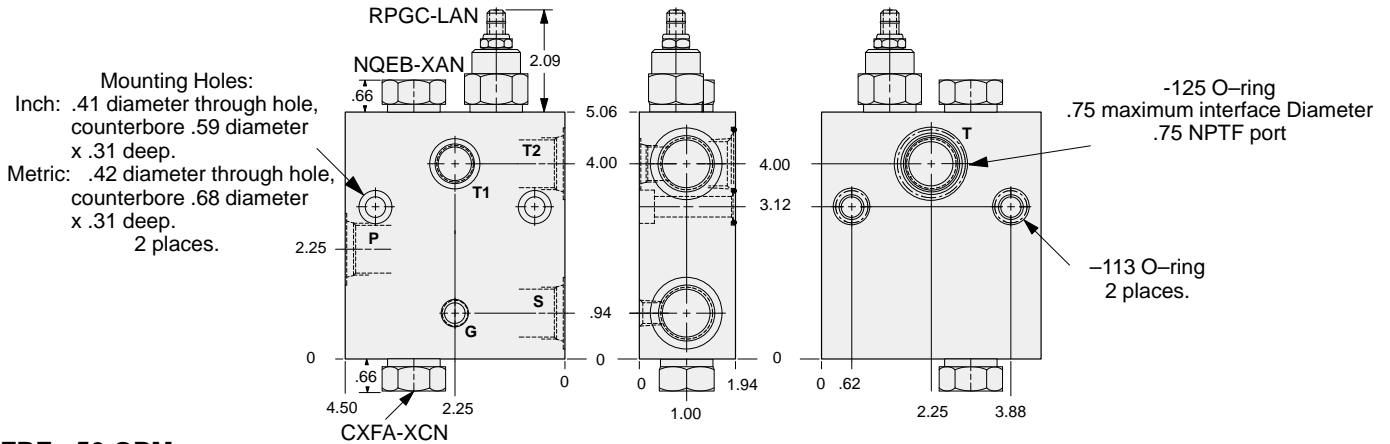

YFRF: 50 GPM

Mounting Hole Dimensions	Port P, S, & T2	Port T1	Gage Port	ALUMINUM		DUCTILE IRON	
				Port Code	List Price*	Port Code	List Price*
Inch	1.00 NPTF	.75 NPTF	.25 NPTF	E		E/S	
Inch	SAE-16	SAE-12	.25 NPTF	M		M/S	
Metric	1.00 BSPP	.75 BSPP	.25 BSPP	X		X/S	

*For part number and price for body only contact your local SUN distributor.

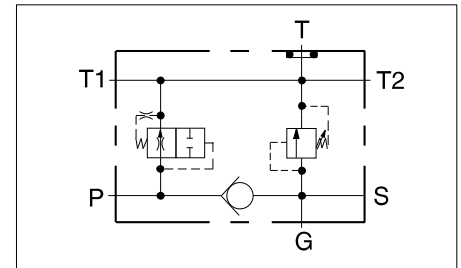

13

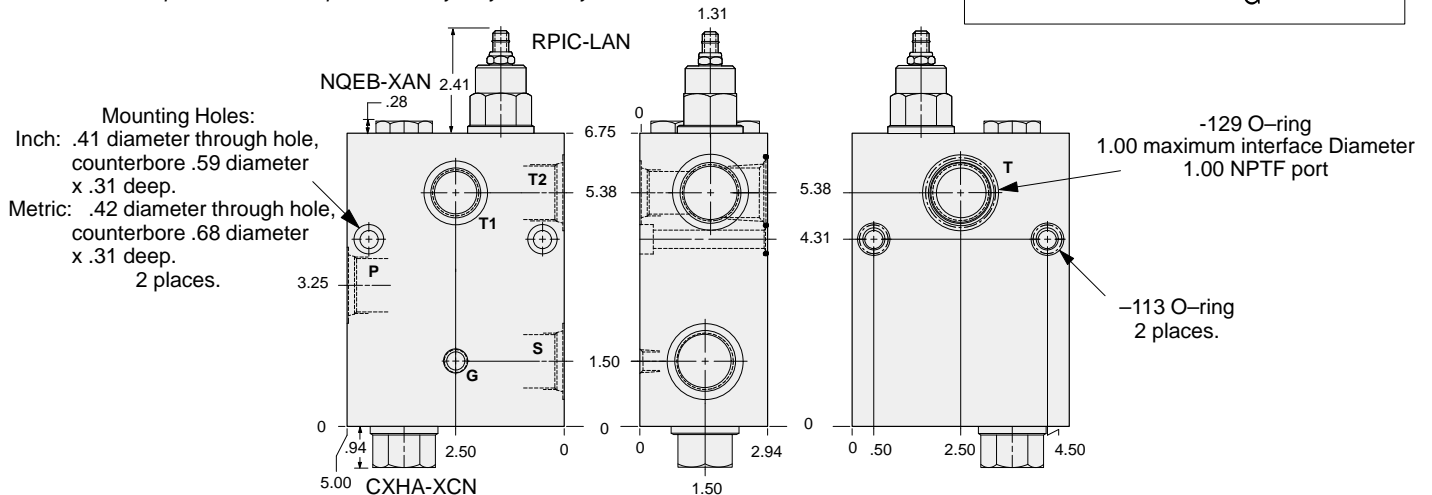

OPTIONS

YFR* - LAN - A*

FLOW CAPABILITY

D 25 GPM
RPGC Cartridge

F 50 GPM
RPIC Cartridge

Customer Specified Setting
Stamped on Hex

For Viton Seals Change
LAN to LAV.

For Viton Seals Change
LAN to LAV.

PORTS

See Chart
above



PRESSURE-COMPENSATED PRIORITY FLOW CONTROL ASSEMBLY WITH RELIEF ON CONTROLLED FLOW PORT

Customer Must Specify Flow ⊗



- Aluminum rated to 3000 psi and Ductile Iron rated to 5000 psi.

YRDR: Up to 6 GPM Priority Flow.

Ports EF & P	Ports CF & T	Gage Port	ALUMINUM		DUCTILE IRON	
			Port Code	List Price*	Port Code	List Price*
.25 NPTF	.25 NPTF	.25 NPTF	A		A/S	
.375 NPTF	.375 NPTF	.25 NPTF	B		B/S	
.50 NPTF	.375 NPTF	.25 NPTF	C		C/S	
SAE-6	SAE-6	.25 NPTF	I		I/S	
SAE-8	SAE-8	.25 NPTF	J		J/S	
SAE-10	SAE-8	.25 NPTF	K		K/S	
.25 BSPP	.25 BSPP	.25 BSPP	T		T/S	
.375 BSPP	.375 BSPP	.25 BSPP	U		U/S	
.50 BSPP	.375 BSPP	.25 BSPP	V		V/S	

*For part number and price for body only contact your local SUN distributor.

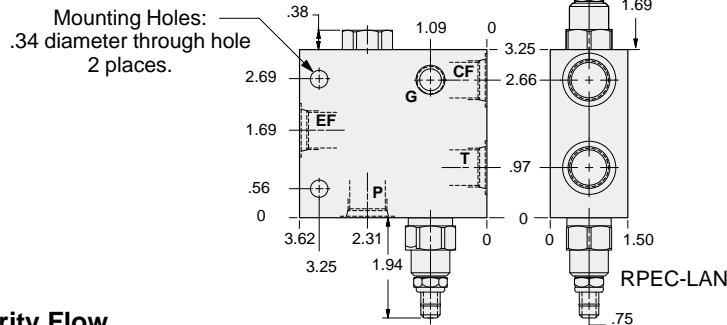
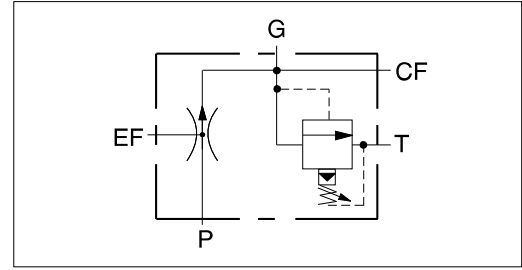

YREM: Up to 12 GPM Priority Flow.

Ports EF & P	Ports CF & T	Gage Port	ALUMINUM		DUCTILE IRON	
			Port Code	List Price*	Port Code	List Price*
.50 NPTF	.50 NPTF	.25 NPTF	C		C/S	
.75 NPTF	.50 NPTF	.25 NPTF	D		D/S	
SAE-10	SAE-10	.25 NPTF	K		K/S	
SAE-12	SAE-10	.25 NPTF	L		L/S	
.50 BSPP	.50 BSPP	.25 BSPP	V		V/S	
.75 BSPP	.50 BSPP	.25 BSPP	W		W/S	

*For part number and price for body only contact your local SUN distributor.

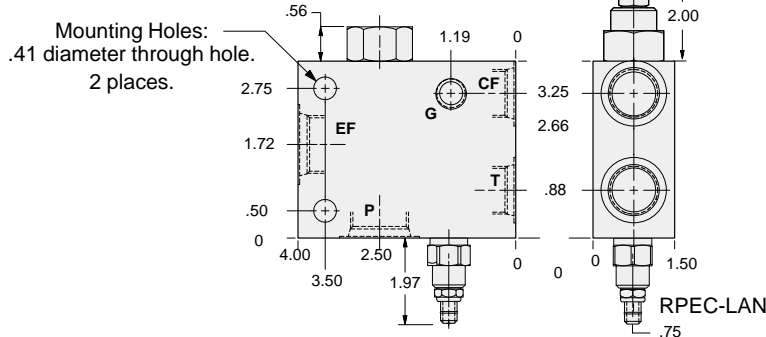
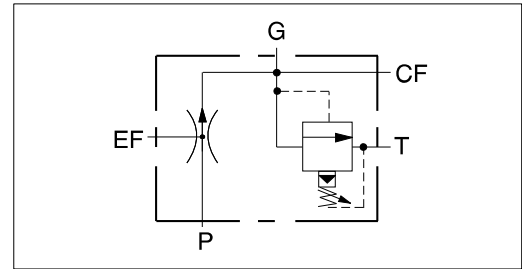

OPTIONS

YR** - LAN - **

FLOW CAPACITY

- DR** Up to 6 GPM For Viton Seals Change LAN to LAV.
- EM** Up to 12 GPM Customer Specified Setting Stamped on Hex

FLOW ADJUSTMENT

- L** Tuning Adjust
- X** Non-adjustable

PORTS

See Chart above

⊗ *Customer must specify flow.
0.1 to 12.0 GPM*



PRESSURE-COMPENSATED PRIORITY FLOW CONTROL ASSEMBLY WITH RELIEF ON CONTROLLED FLOW PORT

Customer Must Specify Flow ⊗



- Aluminum rated to 3000 psi and Ductile Iron rated to 5000 psi.

YRFF: Up to 25 GPM Priority Flow.

Ports EF & P	Ports CF & T	Gage Port	ALUMINUM		DUCTILE IRON	
			Port Code	List Price*	Port Code	List Price*
.75 NPTF	.75 NPTF	.25 NPTF	D		D/S	
1.00 NPTF	.75 NPTF	.25 NPTF	E		E/S	
1.25 NPTF	.75 NPTF	.25 NPTF	F		F/S	
SAE-12	SAE-12	.25 NPTF	L		L/S	
SAE-16	SAE-12	.25 NPTF	M		M/S	
SAE-20	SAE-12	.25 NPTF	N		N/S	
.75 BSPP	.75 BSPP	.25 BSPP	W		W/S	
1.00 BSPP	.75 BSPP	.25 BSPP	X		X/S	
1.25 BSPP	.75 BSPP	.25 BSPP	Y		Y/S	

*For part number and price for body only contact your local SUN distributor.

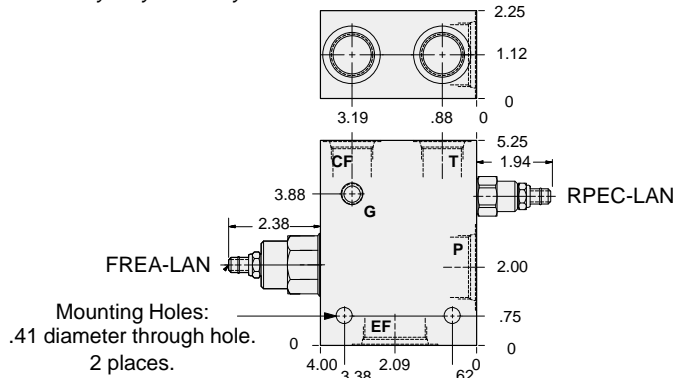
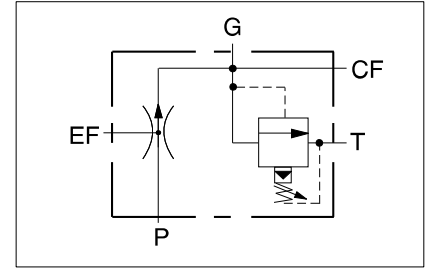

Mounting Hole Dimensions	Ports EF & P Code 61	Ports CF & T Code 61	Gage Port	ALUMINUM		DUCTILE IRON	
				Port Code	List Price*	Port Code	List Price*
Inch	1.00"	1.00"	.25 NPTF	P		P/S	
Metric	1.00"	1.00"	.25 BSPP	P/M		P/T	
Inch	1.25"	1.00"	.25 NPTF	Q		Q/S	
Metric	1.25"	1.00"	.25 BSPP	Q/M		Q/T	

*For part number and price for body only contact your local SUN distributor.

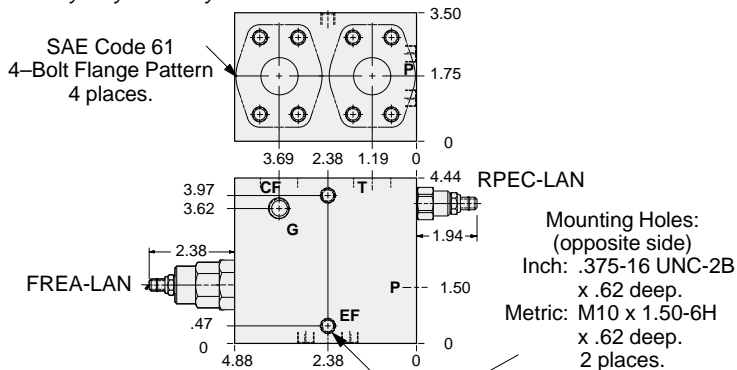
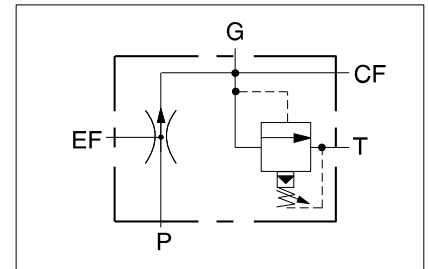

13

OPTIONS	YRFF - LAN - * *	
<p>FLOW ADJUSTMENT</p> <p>L Tuning Adjust</p> <p>X Non-adjustable</p>	<p>For Viton Seals Change LAN to LAV.</p> <p>Customer Specified Setting Stamped on Hex</p>	<p>PORTS</p> <p>See Chart above</p>
		<p>⊗ <i>Customer must specify flow. 0.2 to 25 GPM</i></p>



PRESSURE-COMPENSATED PRIORITY FLOW CONTROL ASSEMBLY WITH RELIEF ON CONTROLLED FLOW PORT

Customer Must Specify Flow ⊗



- Aluminum rated to 3000 psi and Ductile Iron rated to 5000 psi.

YRHF: Up to 50 GPM Priority Flow.

Mounting Hole Dimensions	Ports EF & T Code 61	Ports CF & T Code 61	Gage Port	ALUMINUM		DUCTILE IRON	
				Port Code	List Price*	Port Code	List Price*
Inch	2.00"	1.50"	.25 NPTF	S		S/S	
Metric	2.00"	1.50"	.25 BSPP	S/M		S/T	

*For part number and price for body only contact your local SUN distributor.

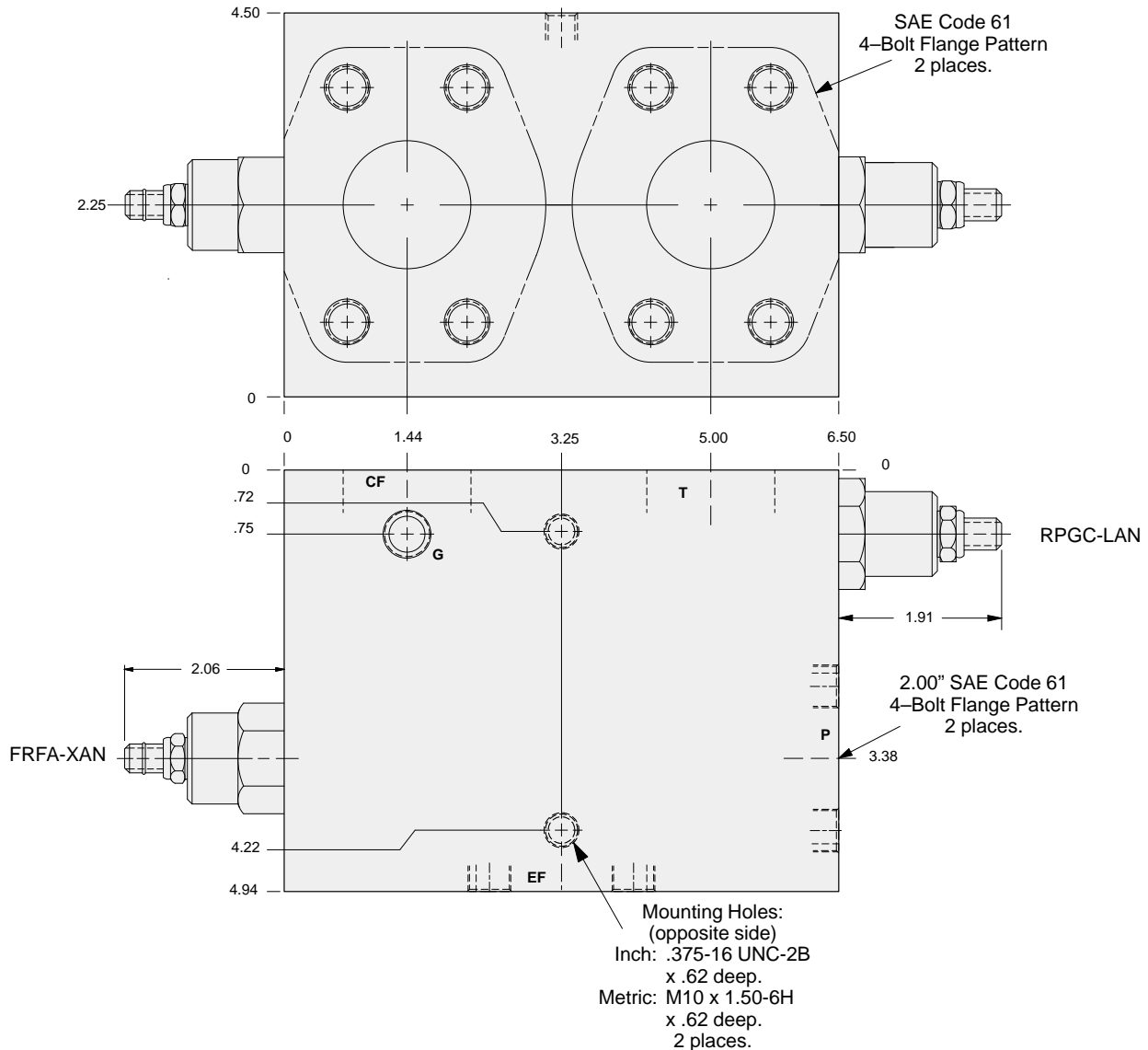
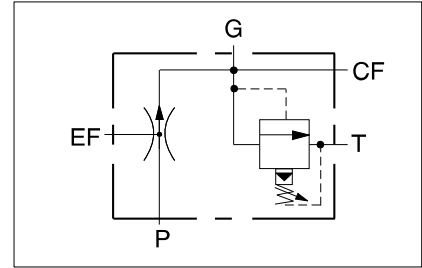

13

OPTIONS	YRHF - LAN - * *	
FLOW ADJUSTMENT		PORTS
L Tuning Adjust X Non-adjustable	For Viton Seals Change LAN to LAV. Customer Specified Setting Stamped on Hex	See Chart above
⊗ <i>Customer must specify flow. 0.2 to 50 GPM</i>		



VALVE ASSEMBLY PACKAGE CROSS REFERENCE CHART



This catalog contains many new bodies that incorporate a free flow check valve and are designated by a three-position model code. These new products provide a functional replacement, and in most cases a physical replacement, for products that were offered only as valve assemblies in previous catalogs. (A SUN Valve Assembly (or Y Assembly), by definition, contains two or more dissimilar cartridges to provide a specific hydraulic function.)

In all cases where a new body with free flow check is available, it is offered in place of the older configuration valve assemblies that have appeared in previous catalogs. **No models that appeared in previous catalogs have been obsoleted. All previously cataloged products can still be ordered using their original model codes.** However, the preferred method of ordering these products is now as follows: **Old Model Code:** YPEF-ABN-BA, **New Model Code:** Cartridge-PBFC-ABN and Body-BB2.

The new method of ordering combines the seven-position cartridge model code (PBFC-ABN) with the three-position body model code (BB2) to create the new valve assembly model code. The cross references that follow detail the differences between older SUN catalogs and this SUN catalog in regard to valve assemblies.

FUNCTIONAL AND PHYSICAL REPLACEMENTS

Assembly Model Number	Catalog Number Cartridge Body	Assembly Model Number	Catalog Number Cartridge Body	Assembly Model Number	Catalog Number Cartridge Body
YCCD-***-A*	CBCA-***-EM*	YCGH-***-G*	CBGG-***-HN*	YPFJ-BBN-BB	PBHC-BBN-BKJ
YCCD-***-G*	CBCG-***-EM*	YCGH-***-H*	CBGH-***-HN*	YPFK-BBN-BB	PPHC-BBN-BK2
YCCD-***-H*	CBCH-***-EM*	YCHC-***-A*	RPIC-***-IN*	YPGA-***-C*	PBHB-***-H2*
YCCE-***-A*	CBCA-***-EP*	YCJC-***-AS	RPKC-***-LNS	YPGB-***-C*	PBHB-***-H3*
YCCE-***-G*	CBCG-***-EP*	YPCA-***-AA	PBDB-***-EB2	YPGC-***-C*	PPHB-***-H4*
YCCE-***-H*	CBCH-***-EP*	YPCB-***-AA	PBDB-***-EB3	YPGD-***-CA	PBHB-***-HBK
YCCG-***-A*	CBCA-***-EQ*	YPCR-***-AA	PPDB-***-EB3	YPGE-***-CA	PPHB-***-HBK
YCCG-***-G*	CBCG-***-EQ*	YPCS-***-AA	PPDB-***-EB2	YPJA-***-C*	PBJB-***-K2*
YCCG-***-H*	CBCH-***-EQ*	YPDB-***-C*	PBDB-***-E3*	YPJC-***-C*	PPJB-***-K4*
YCCH-***-A*	CBCA-***-EN*	YPDD-***-C*	PPDB-***-E4*	YRCA-***-AA	RPEC-***-FB2
YCCH-***-G*	CBCG-***-EN*	YPDE-***-C*	PPDB-***-E5*	YRDK-***-A*	RPEC-***-FM*
YCCH-***-H*	CBCH-***-EN*	YPEB-***-BA	PBFB-***-BB2	YREC-***-BA	RPGC-***-CB2
YCDC-***-**	RPEC-***-FN*	YPED-***-BA	PBFB-***-BB3	YRER-***-BB	RPGC-***-CJ2
YCED-***-A*	CBEA-***-BM*	YPEE-***-BB	PBFB-***-BJ2	YRFK-***-A*	RPGC-***-CM*
YCED-***-G*	CBEG-***-BM*	YPEF-ABN-BA	PBFC-ABN-BB2	YRHK-***-A*	RPIC-***-IM*
YCED-***-H*	CBEH-***-BM*	YPEG-ABN-BA	PBFC-ABN-BB3	YSCB-***-AA	RSDC-***-EB5
YCEE-***-A*	CBEA-***-BP*	YPEH-ABN-BA	PPFC-ABN-BB2	YSCC-***-AA	RSDC-***-EB4
YCEE-***-G*	CBEG-***-BP*	YPEI-ABN-BA	PPFC-ABN-BB3	YSDB-***-C*	RSDC-***-E7*
YCEE-***-H*	CBEH-***-BP*	YPEL-***-C*	PPFB-***-B4*	YSDC-***-C*	RSDC-***-E8*
YCEG-***-A*	CBEA-***-BQ*	YPEM-***-C*	PPFB-***-B5*	YSEB-***-C*	RSFC-***-B7*
YCEG-***-G*	CBEG-***-BQ*	YPER-***-BA	PPFB-***-BB2	YSEC-***-C*	RSFC-***-B8*
YCEG-***-H*	CBEH-***-BQ*	YPES-***-BA	PPFB-***-BB3	YSEF-***-BA	RSFC-***-BB5
YCEH-***-A*	CBEA-***-BN*	YPET-***-BB	PBFB-***-BJ3	YSEG-***-BA	RSFC-***-BB4
YCEH-***-G*	CBEG-***-BN*	YPEU-ABN-BB	PBFC-ABN-BJ2	YSEI-***-BB	RSFC-***-BJ5
YCEH-***-H*	CBEH-***-BN*	YPEV-ABN-BB	PBFC-ABN-BJ3	YSEL-***-C*	RSFC-***-B6*
YCFC-***-**	RPGC-***-CN*	YPEW-ABN-BB	PPFC-ABN-BJ2	YSEJ-***-BB	RSFC-***-BJ4
YCGD-***-A*	CBGA-***-HM*	YPEX-ABN-BB	PPFC-ABN-BJ3	YSFB-***-AB	RSHC-***-BK4
YCGD-***-G*	CBGG-***-HM*	YPEY-***-BB	PPFB-***-BJ2	YSFC-***-AB	RSHC-***-BK5
YCGD-***-H*	CBGH-***-HM*	YPEZ-***-BB	PPFB-***-BJ3	YSGA-***-CA	RSHC-***-HB4
YCGE-***-A*	CBGA-***-HP*	YPDF-***-C*	PBFB-***-B3*	YSHA-***-C*	RSHC-***-H6*
YCGE-***-G*	CBGG-***-HP*	YPFE-***-AB	PBHB-***-BK2	YSHB-***-C*	RSHC-***-H7*
YCGE-***-H*	CBGH-***-HP*	YFFF-***-AB	PBHB-***-BKJ	YSHC-***-C*	RSJC-***-K8*
YCGG-***-A*	CBGA-***-HQ*	YPIG-***-AB	PPHB-***-BK2		
YCGG-***-G*	CBGG-***-HQ*	YPIH-***-AB	PPHB-***-BKJ		
YCGG-***-H*	CBGH-***-HQ*	YPII-BBN-BB	PBHC-BBN-BK2		
YCGH-***-A*	CBGA-***-HN*	YPIF-BBN-BB	PPHC-BBN-BKJ		

Continued on next page



VALVE ASSEMBLY PACKAGE CROSS REFERENCE CHART *(continued)*



FUNCTIONAL ONLY REPLACEMENTS

New nine-position model codes in the following chart are physically different than the old Y Assembly models. Differences may include physical size as well as port locations, so make sure these products are suitable to your application before ordering.

The new XR** hydrostatic transmission valve assemblies referenced below are not only physically different, but also represent a new design. This new version hydrostatic transmission valve assembly offers superior performance characteristics and greater application flexibility compared to the older version YR** hydrostatic transmission assemblies.

<i>Y Assembly</i>	<i>Replacement</i>
YPDA-***-**	PBDB-***-E2*
YRDL-LQN-AK	XRDC-LNN-A*
YRDE-LQN-AL	XRDC-LNN-A*
YRDM-LQN-AM	XRFC-LNN-A*
YRDM-LQN-AM	XRFC-LNN-A*
YRGH-LCN-A*	XRFB-LCN-A*
YRGN-LCN-AQ	XRFB-LCN-AQ
YRGP-LCN-A*	XRDB-LCN-A*
YSDA-***-**	RSDC-***-E6*
YPFB-***-**	PBFB-***-B2

NO REPLACEMENT AND NOT IN THIS CATALOG

The Y assemblies listed in the chart below appeared in previous SUN catalogs but do not appear in this catalog. **These products can still be ordered using the original model code. Contact your distributor for pricing information.**

YCEJ	YFEM	YNEK	YRGD
YDFD	YFEN	YNEM	YRGJ
YFCH	YFEO	YRDC	YRGG
YFCI	YNCF	YREL	YSEH
YFED	YNEJ	YRES	YSEK